

Dimensions and weight

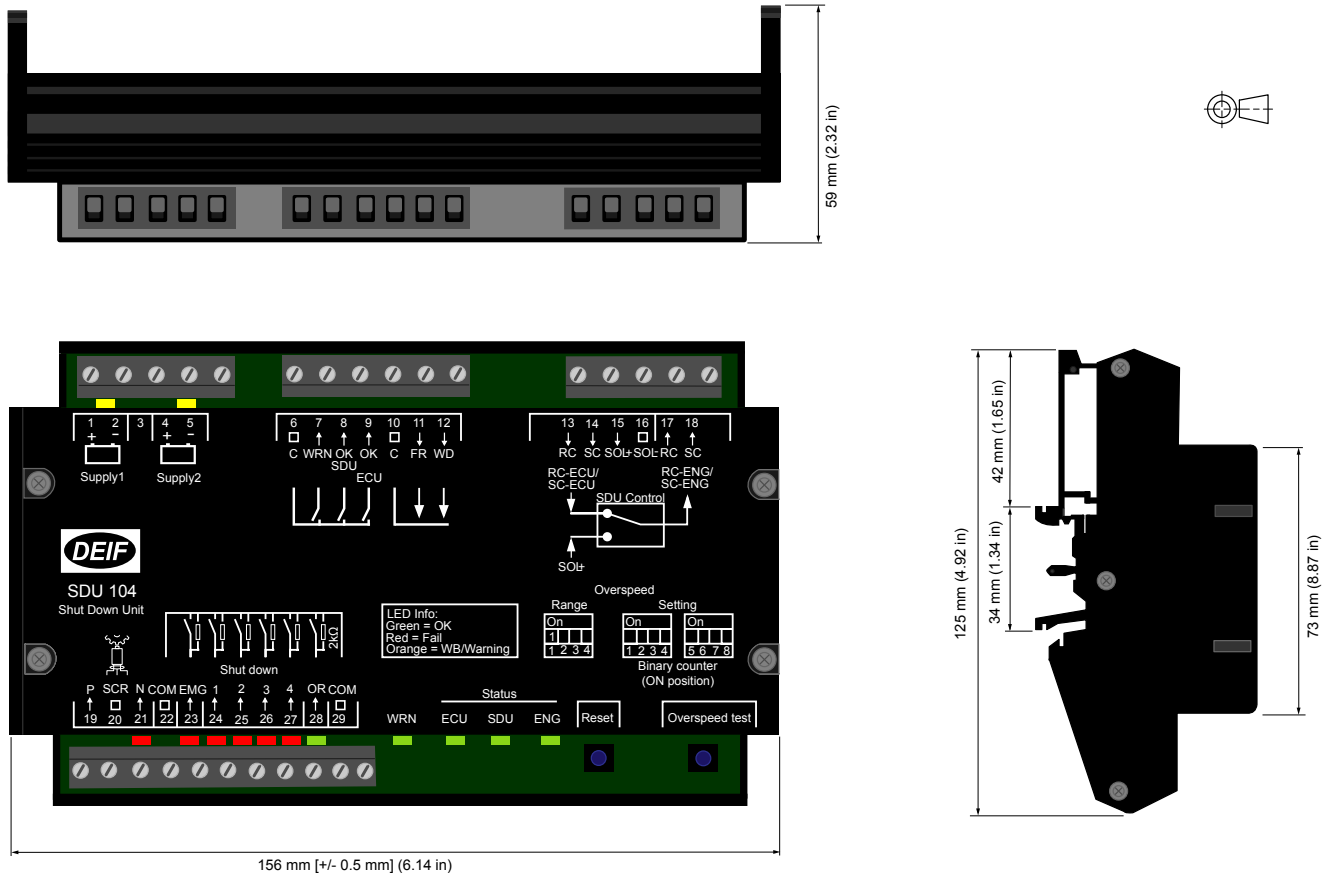

Dimensions and weight

Dimensions	Length: 156 mm (6.14 in)
	Height: 125 mm (4.92 in)
	Depth: 59 mm (2.32 in)
Weight	0.79 kg

Environment

Install the SDU 104 in a dry and dust free environment.

If you do not install the SDU 104 immediately, then store it in the original shipping package in a dry and dust free environment.

The SDU 104 operation temperature range is -40 to +70 °C.

NOTICE



Warranty

The controller is not to be opened by unauthorised personnel. If opened anyway, the warranty will be lost.

Installation

Install the SDU 104 in a closed cabinet on a DIN rail. You can mount it on a TS35 or G-type rail.

Terminals

5-pin 5.08 mm terminal block	Terminal	Name	Description	Comment
	1	+		Power supply 1
	2	-	Internal GND	
	3		Not connected	
	4	+		Power supply 2
	5	-	Internal GND	
7-pin 5.08 mm terminal block	Terminal	Name	Description	Comment
	6	C	DC level for switching out (connected Vbatt+ or Vbatt-)	Common for ECU interface (terminal 7, 8 and 9)
	7	WRN	No warning = switch closed	Warning status
	8	OK SDU	No fail = switch closed	SDU status
	9	OK ECU	No fail = switch closed	Controller status
	10	C	Reference for digital input FR - WD. Galvanic separated.	Common for terminals 11 and 12
	11	FR	Galvanic separated	Fault reset input (same function as the reset button)
	12	WD	Galvanic separated	Watchdog input (from ECU)
6-pin 5.08 mm terminal block with screw lock	Terminal	Name	Description	Comment
	13	RC	12 or 24 V	Run coil input
	14	SC	12 or 24 V	Stop coil input
	15	SOL+	12 or 24 V	Take-over supply
	16	SOL-	Connect to Batt-	Common for terminals 13, 14, and 15
	17	RC		Run coil output
	18	SC		Stop coil output

11-pin 5.08 mm terminal block	Terminal	Name	Description	Comment
	19	P		MPU, NPN, PNP, or W input
	20	SCR	Connect to cable shield (GND)	
	21	N		
	22	COM		Common for terminals 23 to 28
	23	EMG	2 K Ω /relay switch	Emergency stop input
	24	1	2 K Ω /relay switch	Shutdown input 1
	25	2	2 K Ω /relay switch	Shutdown input 2
	26	3	2 K Ω /relay switch	Shutdown input 3
	27	4	2 K Ω /relay switch	Shutdown input 4
	28	OR	2 K Ω /relay switch	Shutdown override input
	29	COM		Common for terminals 23 to 28

NOTE Use of the safety system on main propulsion engines should be carefully considered during the design review. This is because all the digital input signals of the SDU 104 can be overridden by activating the override function, except for the overspeed and emergency stop buttons.

Power supply

If you only use power supply 1, then you must connect a jump wire between power supply 1 and power supply 2. This is to make sure that the power supplies are connected in parallel.

Shutdown inputs

If a shutdown input is not used, then you must use a 2 k Ω resistor to connect the unused input to common.

NOTE DEIF recommends that you use a 2 k Ω resistor, but you can also use a resistor with a resistance of 1.8 k Ω to 2.5 k Ω .



DANGER!



Installation error

The installation must only be carried out by authorised personnel who understand the risks involved in working with electrical equipment.

Wiring

Typical wiring for SDU 104 and an iE 150 or AGC 150 controller.

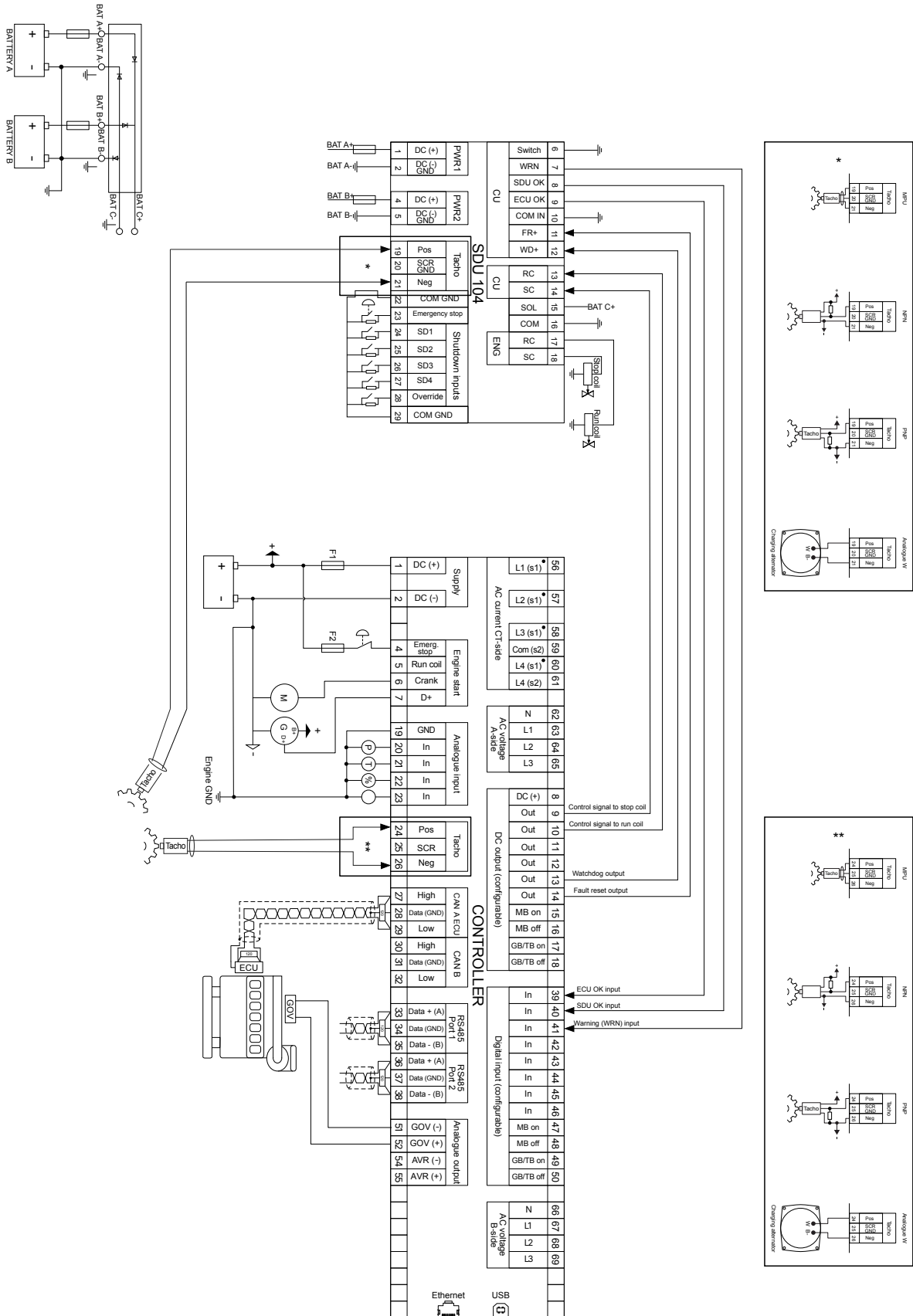

Example: Configure the SDU 104 for use with an iE 150 or AGC 150 controller

The controller continuously triggers the watchdog input on the SDU. This is a special heartbeat signal from the controller, and this is an example of how to configure the SDU 104 for use with an iE 150 or AGC 150 controller.

1. Go to the *I/O & Hardware setup* tab.
2. Select the *DI 39-40-41* tab.
3. Configure the digital inputs:
 - Digital input 39: SDU comm error
 - Digital input 40: SDU status OK
 - Digital input 41: SDU warning
4. Go to the *DO 5 - 18* tab.
5. Configure *Output 13* and *Output 14*:
 - Output 13: SDU watchdog
 - Output 14: SDU fault reset
6. Go to the *Parameters* tab to configure SDU parameters 18000, 18010, and 18020. These parameters are the alarms for the digital inputs.

By default, digital output 11 is configured as *Status OK*. This output must be configured for the SDU watchdog output to work.

Configuration of overspeed settings

You can test the overspeed function by pushing the overspeed button on the controller. When you push the button, the limit for overspeed is reduced by 50 %. This causes the engine to shut down.

Remove the cover to access the overspeed switches. Use the switches to set the range for overspeed, and to set the overspeed set point. You do not need to remove the dust covers on the switches.

NOTE The switches are placed under a cover due to safety.

Step	Action	Example
1	Calculate the tooth frequency at overspeed. Tooth frequency = Overspeed [RPM] * (No. of teeth/60)	Tooth frequency = 1600 RPM * (120 teeth/60) = 3200 Hz
2	Use the Overspeed range table in this section to select a range.	Tooth frequency = 3200 Hz Range = 1 Divider = 32
3	Calculate the overspeed set point	Set point = 3200 Hz/32 = 100. This is a binary number.

NOTE The overspeed settings depend on the maximum engine speed.

Overspeed range

Range	Speed range	Input divider	Gate time	Resolution
1	65 to 8160 Hz	32 (int 512 Hz set)	1 s	40 Hz
2	8 to 2048 Hz	8 (int 128 Hz set)	4 s	10 Hz
3	2 to 512 Hz	2 (int 32 Hz set)	16 s	2.5 Hz
4	0.5 to 128 Hz	0.5 (int 8 Hz set)	64 s	0.7 Hz

NOTE The typical overspeed range is 1 as this gives the fastest response time.

Binary numbers

The overspeed set point is a binary number. Each of the two switches used for the overspeed set point has four switches on it labelled 1, 2, 3, and 4 and 5, 6, 7, and 8.

These numbers follow a binary numbering system, which means that 1 = 1, 2 = 2, 3 = 4, 4 = 8, 5 = 16, 6 = 32, 7 = 64, and 8 = 128. There is an ON and OFF position for each switch, where OFF = 0 and ON = 1.



Examples

Example 1

This example shows how to set the switches to 250. To do this, set switches 2, 5, 6, 7, and 8 to ON, and the remaining switches to OFF.

This equals to 250 as follows: $((0 \times 1) + (1 \times 2) + (0 \times 4) + (1 \times 8) + (1 \times 16) + (1 \times 32) + (1 \times 64) + (1 \times 128)) = 0 + 2 + 0 + 8 + 16 + 32 + 64 + 128 = 250$

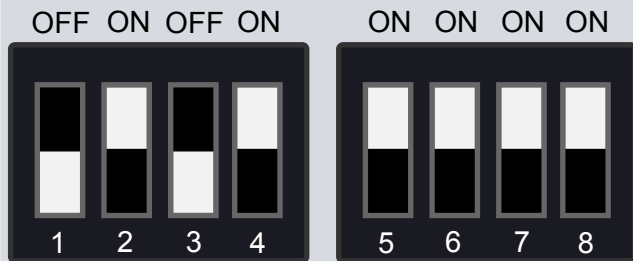

Example 2

This example shows how to set the switches to 100. To do this, set switches 3, 6, and 7 to ON, and the remaining switches to OFF.

This equals to 100 as follows: $((0 \times 1) + (0 \times 2) + (1 \times 4) + (0 \times 8) + (0 \times 16) + (1 \times 32) + (1 \times 64) + (0 \times 128)) = 0 + 0 + 4 + 0 + 0 + 32 + 64 + 0 = 100$

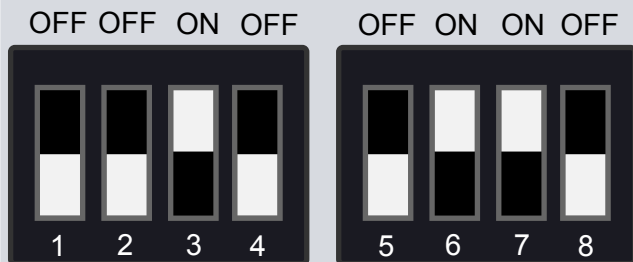

Disclaimer

DEIF A/S reserves the right to change any of the contents of this document without prior notice.

The English version of this document always contains the most recent and up-to-date information about the product. DEIF does not take responsibility for the accuracy of translations, and translations might not be updated at the same time as the English document. If there is a discrepancy, the English version prevails.

Copyright

© Copyright DEIF A/S. All rights reserved.

More information



Visit: www.deif.com/documentation/sdu

See the **Data sheet** for information about technical specifications.

See the **SDU 140 Application notes** for how to use the SDU 104 with the iE 250 and iE 350 controllers.