

SGC 420 Mk II

Single Genset Controller

User manual

4189341360-C

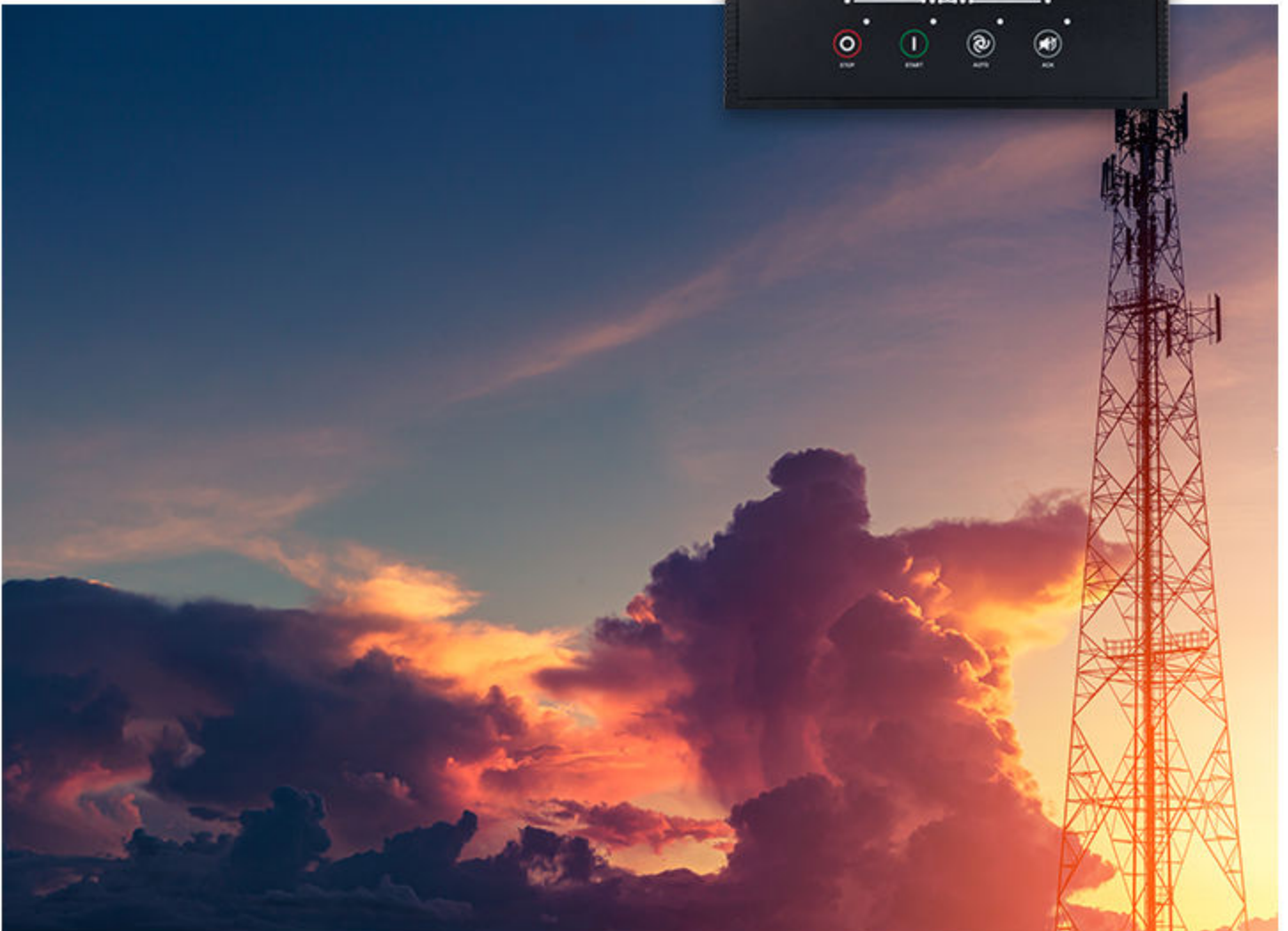

1. Introduction	
1.1 About	5
1.1.1 Function overview	5
1.2 About the User manual	6
1.2.1 General purpose	6
1.2.2 Software version	6
1.3 Warnings and safety	6
1.4 Legal information	7
2. Installation	
2.1 Dimensions and weight	8
2.2 Tools and materials	8
2.3 Mounting	9
2.4 Terminals	10
3. Wiring	
3.1 Typical wiring	13
3.2 Wiring guidelines - best practice for grounding	14
3.3 AC connections	15
3.3.1 I4 current	17
3.3.2 Current transformer (CT) ground	17
3.3.3 Voltage measurement fuses	17
3.3.4 Analogue inputs	18
3.4 DC connections	20
3.4.1 Digital inputs	20
3.4.2 Digital outputs	21
3.4.3 Power supply and start	21
3.5 Communications	22
3.5.1 CAN bus engine communication	22
3.5.2 Modbus RS-485	22
4. Smart Connect Mk II software	
4.1 Download the smart connect software	24
4.2 USB connection	24
4.3 Smart connect interface	24
4.3.1 Top toolbar	24
4.3.2 Left menu	27
4.3.3 Live Simulation Button	28
5. Display and menus	
5.1 Display, buttons, and LEDs	30
5.2 Mode and menu selection	31
5.3 Display settings	31
5.3.1 Display	31
5.3.2 Power save function	31
5.3.3 Deep sleep function	31
5.4 Monitoring menu	32
5.4.1 Load histogram	32
5.4.2 EGR status monitoring	32
5.5 Configuration menu	33
5.5.1 Auto exit config mode	34
5.6 Parameter list	34

5.6.1 Module.....	34
5.6.2 Digital inputs.....	37
5.6.3 Digital outputs.....	37
5.6.4 Analogue inputs.....	37
5.6.5 Engine.....	38
5.6.6 Timers.....	44
5.6.7 Generator.....	45
5.6.8 Mains.....	50
5.6.9 ECU Configuration.....	52
5.6.10 Maintenance.....	54
5.6.11 Reset counters.....	54
5.6.12 Password ID.....	55
6. Modes and applications	
6.1 Running mode.....	56
6.2 AUTO mode.....	56
6.2.1 Island.....	56
6.2.2 Engine drive.....	57
6.2.3 Automatic mains failure (AMF).....	57
6.2.4 Site battery monitoring.....	58
6.2.5 Cyclic mode.....	60
6.2.6 Remote start/stop	62
6.2.7 Auto exercise.....	62
6.3 Manual mode.....	64
6.4 Test mode.....	65
6.5 Deep sleep mode.....	65
7. General functions	
7.1 Passwords.....	66
7.2 AC measurement systems.....	66
7.3 Nominal settings.....	66
7.4 Breakers.....	67
7.4.1 Breaker types.....	67
7.4.2 Breaker spring load timer.....	67
7.5 Load calculations.....	67
7.6 Alarms.....	68
7.7 M-Logic.....	75
7.7.1 Logical rungs.....	75
7.7.2 Comparator rungs.....	75
7.7.3 EGR related M-logic.....	76
7.8 Language.....	76
7.8.1 Language pack.....	76
7.8.2 Smart connect language.....	77
8. Engine functions	
8.1 Engine sequences.....	78
8.2 Engine start functions.....	78
8.2.1 Start sequence.....	78
8.3 Engine stop functions.....	80
8.3.1 Stop sequence.....	80
8.3.2 Stop sequence flowchart.....	81

8.4 Idle mode	82
8.5 Coolant temperature control	83
8.6 Engine pre-heater	85
8.7 External EGR monitoring	86
8.7.1 EGR fault detection.....	86
8.7.2 EGR fault supervision.....	87
8.8 Other functions	88
8.8.1 Maintenance timer.....	88
8.8.2 Keyswitch.....	89
9. Modbus	
9.1 About	90
9.2 Connection details	90
9.3 RS-485 communication settings	90
9.4 EGR Modbus communication	90
10. CAN bus engine communication	
10.1 Overview	92
10.1.1 About.....	92
10.1.2 Show engine values in the display.....	92
10.2 Configuration of the engine communication settings	92
10.3 Generic J1939	92
11. Inputs and outputs	
11.1 Digital inputs	93
11.2 EGR digital input	94
11.3 Digital outputs	95
12. Remote Display Controller (RDC)	
12.1 About RDC	99
12.2 Connect the controllers	99
12.3 Configure the controllers	100
12.3.1 Configure the master controller.....	100
12.3.2 Configure the remote display (RDC).....	101
13. Troubleshooting	

1. Introduction

1.1 About

The SGC 420 Mk II controller has all the functions needed to protect and control a genset, a genset breaker, and a mains breaker. The values and alarms are shown on the LCD display screen, and operators can easily control the system from the display.

You can use the SGC 420 Mk II to monitor the site battery and significantly reduce your fuel consumption. The controller can also monitor shelter temperature, engine and alternator parameters, and the true RMS voltage and current.

Use the Smart Connect Mk II software to configure parameters, log data, add custom sensor curves, and supervise live data. M-Logic is also available from the software, which allows you to create functions using pre-defined events and outputs. The analogue comparator can be used to create custom alarms and logic functions.

1.1.1 Function overview

This is an overview of the most important functions.

Monitoring

Use the SGC controller to monitor the site battery and the shelter temperature. The controller can also monitor the mains, and engine and alternator parameters.

Inputs and outputs

- Configurable analogue inputs
- Differential input for site battery voltage
- Digital switch inputs
- DG alternator input
- Mains voltage input (AMF)
- Input for fuel reference selection
- Digital outputs

Communication

- RS-485 for Modbus communication
- CAN bus engine communication
- USB interface to PC

Operation modes

The SGC controller can operate in AUTO mode, manual mode, and test mode.

In AUTO mode, you can select these functions:

- Island
- Site battery monitoring
- Automatic mains failure (AMF)
- Cyclic mode
- Remote start/stop
- Auto exercise
- Engine drive

Display and language functions

- Backlit display
- Supports many languages, including English, Spanish, and Chinese

- Configure and customise the controller display language, and the software language
- 2-level password protection

M-Logic

- Simple logic configuration tool
- Selectable input and output events

1.2 About the User manual

1.2.1 General purpose

This document includes important instructions that should be followed during installation and maintenance of the controller.

Only approved personnel can do the installation and maintenance work. The work must comply with all applicable state and local electrical codes. Efficient and safe operation of the controller is only possible if equipment operation and configuration is correct, and maintenance is completed.



1.2.2 Software version

The information in this document relates to software version:

Software	Version
SGC Application software	R19

1.3 Warnings and safety

Symbols for hazard statements

	WARNING
	<p>This shows potentially dangerous situations.</p> <p>If the guidelines are not followed, these situations could result in death, serious personal injury, and equipment damage or destruction.</p>

	CAUTION
	<p>This shows low level risk situation.</p> <p>If the guidelines are not followed, these situations could result in minor or moderate injury.</p>

Symbols for general notes

NOTE This shows general information.

 **More information**
This shows where you can find more information.

Safety during installation and operation

When you install and operate the equipment, you may have to work with dangerous currents and voltages. The installation must only be carried out by authorised personnel who understand the risks involved in working with electrical equipment.



DANGER!



Hazardous live currents and voltages

Do not touch any terminals, especially the AC measurement inputs or any relay terminals, as this could lead to injury or death.

Current transformer danger



DANGER!



Electrical shock and arc flash

Risk of burns and electrical shock from high voltage.

Short all current transformer secondaries before breaking any current transformer connections to the controller.

Factory settings

The controller is delivered pre-programmed from the factory with a set of default settings. These settings are based on typical values and may not be correct for your system. You must therefore check all parameters and settings before using the controller.

Electrostatic discharge

Electrostatic discharge can damage the controller terminals. You must protect the terminals from electrostatic discharge during the installation. When the controller is installed and connected, these precautions are no longer necessary.

1.4 Legal information

Warranty

NOTICE



Warranty

The controller is not to be opened by unauthorised personnel. If opened anyway, the warranty will be lost.

Disclaimer

DEIF A/S reserves the right to change any of the contents of this document without prior notice.

The English version of this document always contains the most recent and up-to-date information about the product. DEIF does not take responsibility for the accuracy of translations, and translations might not be updated at the same time as the English document. If there is a discrepancy, the English version prevails.

Copyright

© Copyright DEIF A/S. All rights reserved.

2. Installation

2.1 Dimensions and weight

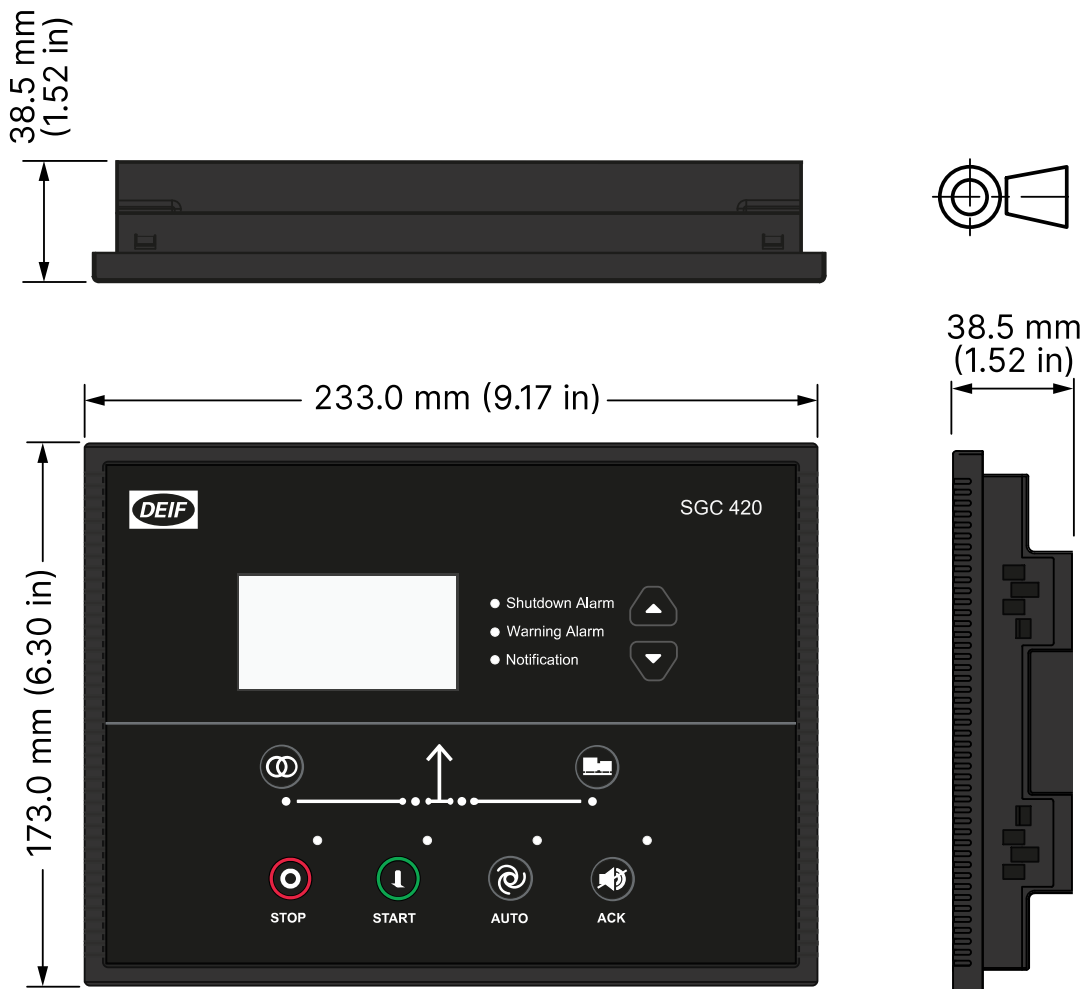

Dimensions

Dimensions	Length: 233.0 mm (9.17 in) Height: 173.0 mm (6.81 in) Depth: 38.5 mm (1.52 in)
Panel cut-out	Length: 219.0 mm (8.62 in) Height: 158.0 mm (6.22 in) Tolerance: ± 0.3 mm (0.01 in)
Weight	With lock: 672 g Without lock: 640 g

2.2 Tools and materials

Tools required for mounting

Tool	Used for
Safety equipment	Personal protection, according to local standards and requirements
Screwdriver, PH2 or 5 mm flat	Tighten the fixing screw clamps, torque 0.15 N·m (1.3 lb-in)
Wire stripper, pliers and cutters	Prepare wiring and trim cable ties

NOTICE



Too much torque damages the screw clamps and/or controller housing

Do not use power tools during the installation.

Materials required for mounting and wiring

Materials	Used for
Four screw clamps	Mounting the controller in the front panel
Wires and connectors	Wiring third party equipment to the controller terminals
Cable ties	Securing wiring

2.3 Mounting

The controller is designed for mounting in the front panel.

Panel cutout:

- Length: 219 mm (8.62 in)
- Height: 150 mm (6.22 in)
- Tolerance: ± 0.3 mm (0.01 in)

1. Insert the controller in the panel.
2. Insert the screw clamps:

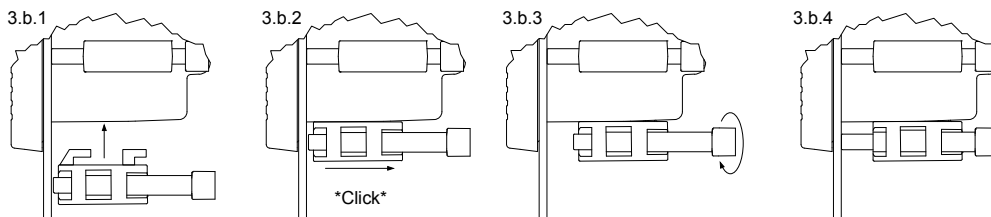

3. Tighten the screw clamps to 0.19 Nm. Do not tighten the clamps to more than 0.19 Nm.

2.4 Terminals

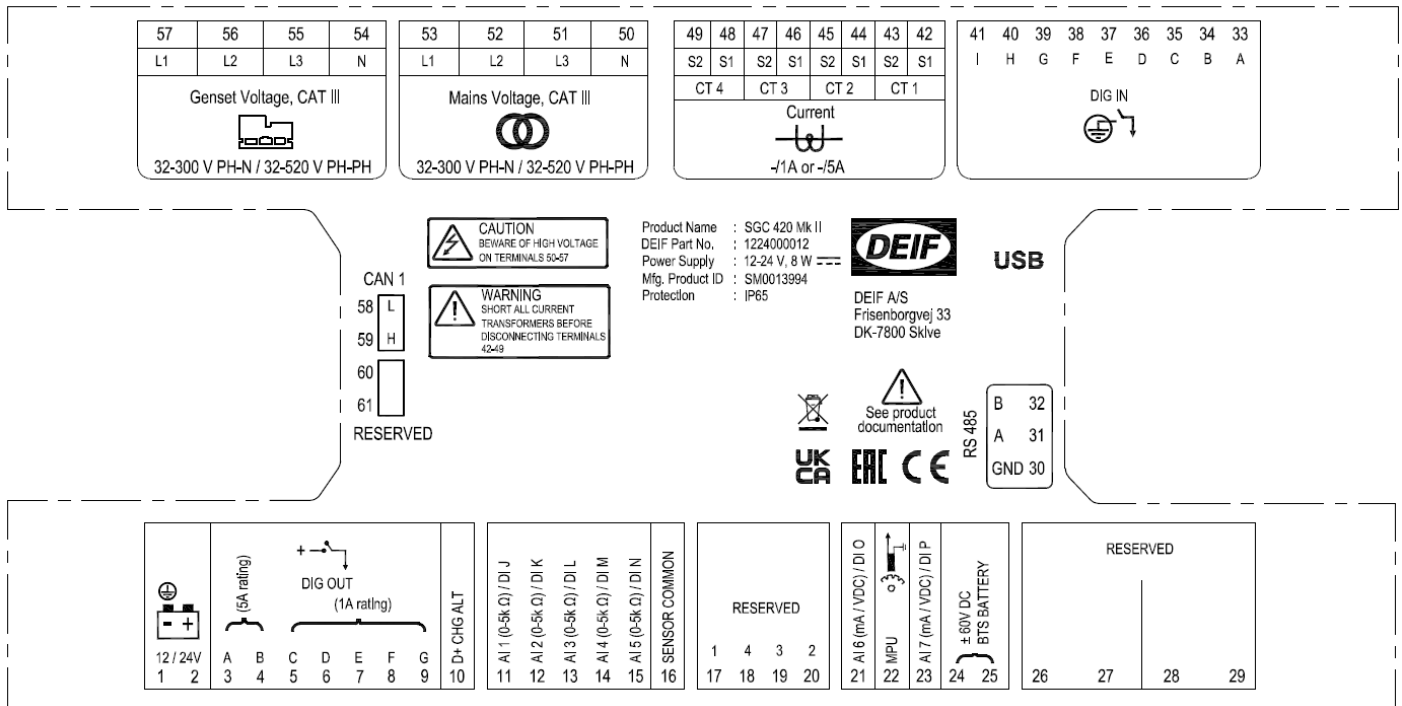

Terminal	Text	Description
1	GND	Power ground
2	BATT +	Power supply positive
3	DIG OUT A	DC output - A (5 A rating)
4	DIG OUT B	DC output - B (5 A rating)
5	DIG OUT C	DC output - C (1 A rating)
6	DIG OUT D	DC output - D (1 A rating)
7	DIG OUT E	DC output - E (1 A rating)
8	DIG OUT F	DC output - F (1 A rating)
9	DIG OUT G	DC output - G (1 A rating)
10	D+ CHG ALT	Input for charging alternator control
11	AI 1 (0-5k Ω) / DI J	Analogue input from list of sensors/digital input J
12	AI 2 (0-5k Ω) / DI K	Analogue input from list of sensors/digital input K
13	AI 3 (0-5k Ω) / DI L	Analogue input from list of sensors/digital input L
14	AI 4 (0-5k Ω) / DI M	Analogue input from list of sensors/digital input M
15	AI 5 (0-5k Ω) / DI N	Analogue input from list of sensors/Digital input N
16	SENSOR COMMON	Sensor common point
17	RESERVED	-
18	RESERVED	-
19	RESERVED	-
20	RESERVED	-
21	AI 6 (mA / VDC) / DI O	Analogue input from list of sensors/digital input O
22	MPU	Input from engine speed sensor (inductive)

Terminal	Text	Description
23	AI 7 (mA / VDC) / DI P	Analogue input from list of sensors/Digital input P
24	BTS BATTERY ± 60 V DC	Input 1 from site battery
25	BTS BATTERY ± 60 V DC	Input 2 from site battery
26	RESERVED	-
27	RESERVED	-
28	RESERVED	-
29	RESERVED	-
30	RS 485 GND	RS-485 GND
31	RS 485 A	RS-485 A
32	RS 485 B	RS-485 B
33	DIG IN A	Input from switch A
34	DIG IN B	Input from switch B
35	DIG IN C	Input from switch C
36	DIG IN D	Input from switch D
37	DIG IN E	Input from switch E
38	DIG IN F	Input from switch F
39	DIG IN G	Input from switch G
40	DIG IN H	Input from switch H
41	DIG IN I	Input from switch I
42	Current CT 1 S1	CT input 1 from phase L1 (-/1A or -/5A)
43	Current CT 1 S2	CT input 2 from phase L1 (-/1A or -/5A)
44	Current CT 2 S1	CT input 1 from phase L2 (-/1A or -/5A)
45	Current CT 2 S2	CT input 2 from phase L2 (-/1A or -/5A)
46	Current CT 3 S1	CT input 1 from phase L3 (-/1A or -/5A)
47	Current CT 3 S2	CT input 2 from phase L3 (-/1A or -/5A)
48	Current CT 4 S1	CT input 1 from earth leakage (-/1A or -/5A)
49	Current CT 4 S2	CT input 2 from earth leakage (-/1A or -/5A)
50	Mains Voltage, CAT III, N	Voltage input from mains neutral (32-300 V PH-N / 32-520 V PH-PH)
51	Mains Voltage, CAT III, L3	Voltage input from mains phase L3 (32-300 V PH-N / 32-520 V PH-PH)
52	Mains Voltage, CAT III, L2	Voltage input from mains phase L2 (32-300 V PH-N / 32-520 V PH-PH)
53	Mains Voltage, CAT III, L1	Voltage input from mains phase L1 (32-300 V PH-N / 32-520 V PH-PH)
54	Genset Voltage, CAT III, N	Voltage input from genset neutral (32-300 V PH-N / 32-520 V PH-PH)
55	Genset Voltage, CAT III, L3	Voltage input from genset phase L3 (32-300 V PH-N / 32-520 V PH-PH)
56	Genset Voltage, CAT III, L2	Voltage input from genset phase L2 (32-300 V PH-N / 32-520 V PH-PH)

Terminal	Text	Description
57	Genset Voltage, CAT III, L1	Voltage input from genset phase L1 (32-300 V PH-N / 32-520 V PH-PH)
58	CAN L (Reserved)	CAN Low
59	CAN H (Reserved)	CAN High
60	Reserved	-
61	Reserved	-

3. Wiring

3.1 Typical wiring

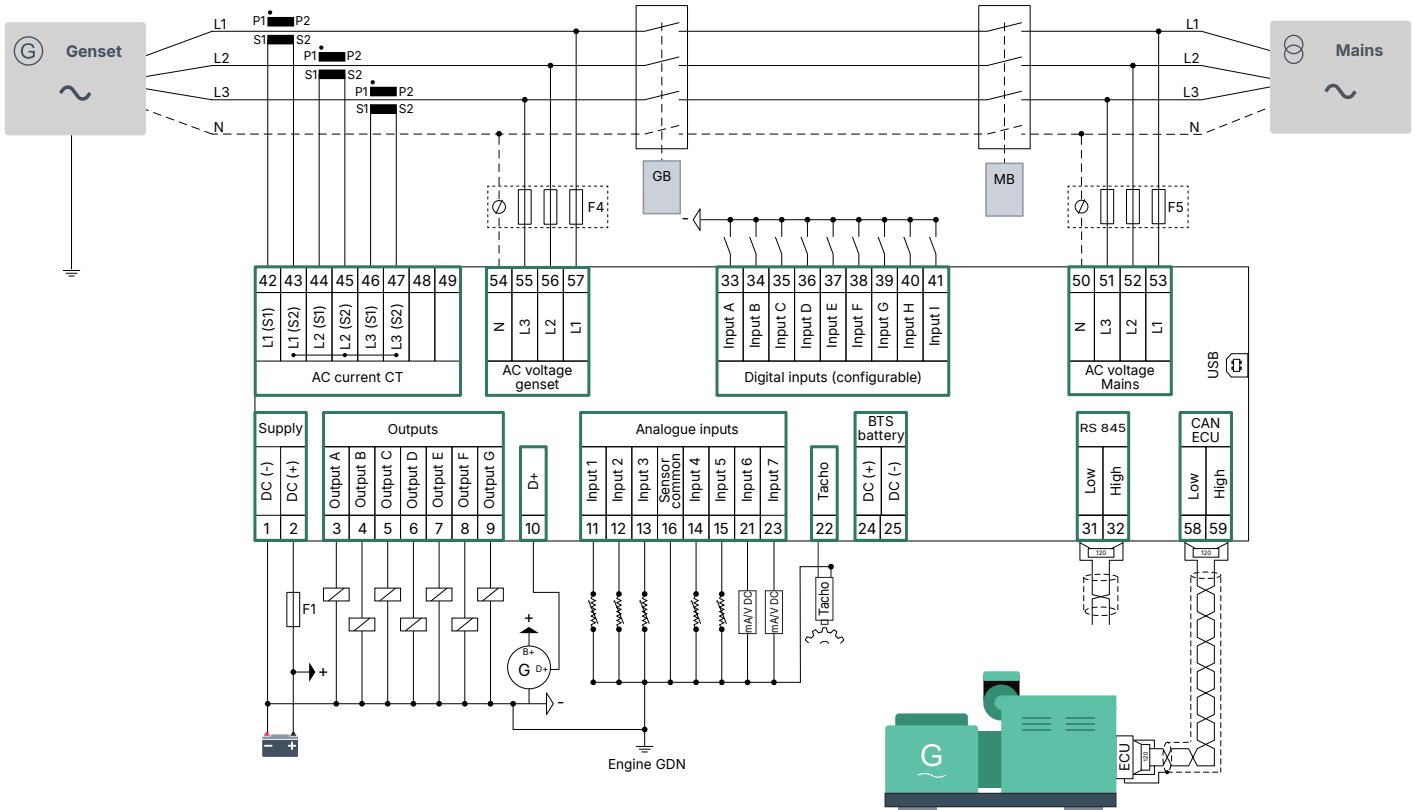

NOTE The S2 terminals are internally shorted.

NOTE The wiring diagram is an example. Use the wiring diagram for the application during installation.

Fuses

- F1: 2 A DC max. time-delay fuse/MCB, c-curve
- F4, F5: 2 A AC max. time-delay fuse/MCB, c-curve.

Relays

- Protect the breaker relays for the genset and mains against 4 kV surges as described in the IEC 61000-4-5 standard.
- Protect relay cards used with the controller against reverse battery voltages.

Communication

Communication ports for CAN (terminals 58 and 59) and RS-485 (terminals 31 and 32) have built-in 120 Ω termination resistors.

Digital outputs

If a digital output is connected to a relay, the relay must include freewheeling diodes.

3.2 Wiring guidelines - best practice for grounding

It is important to follow these wiring guidelines to get:

- Reliable readings from the sensors.
- Precise measurement of AC voltage and current.
- Best protection from lightning and other earth faults.

Example: Typical grounding setup

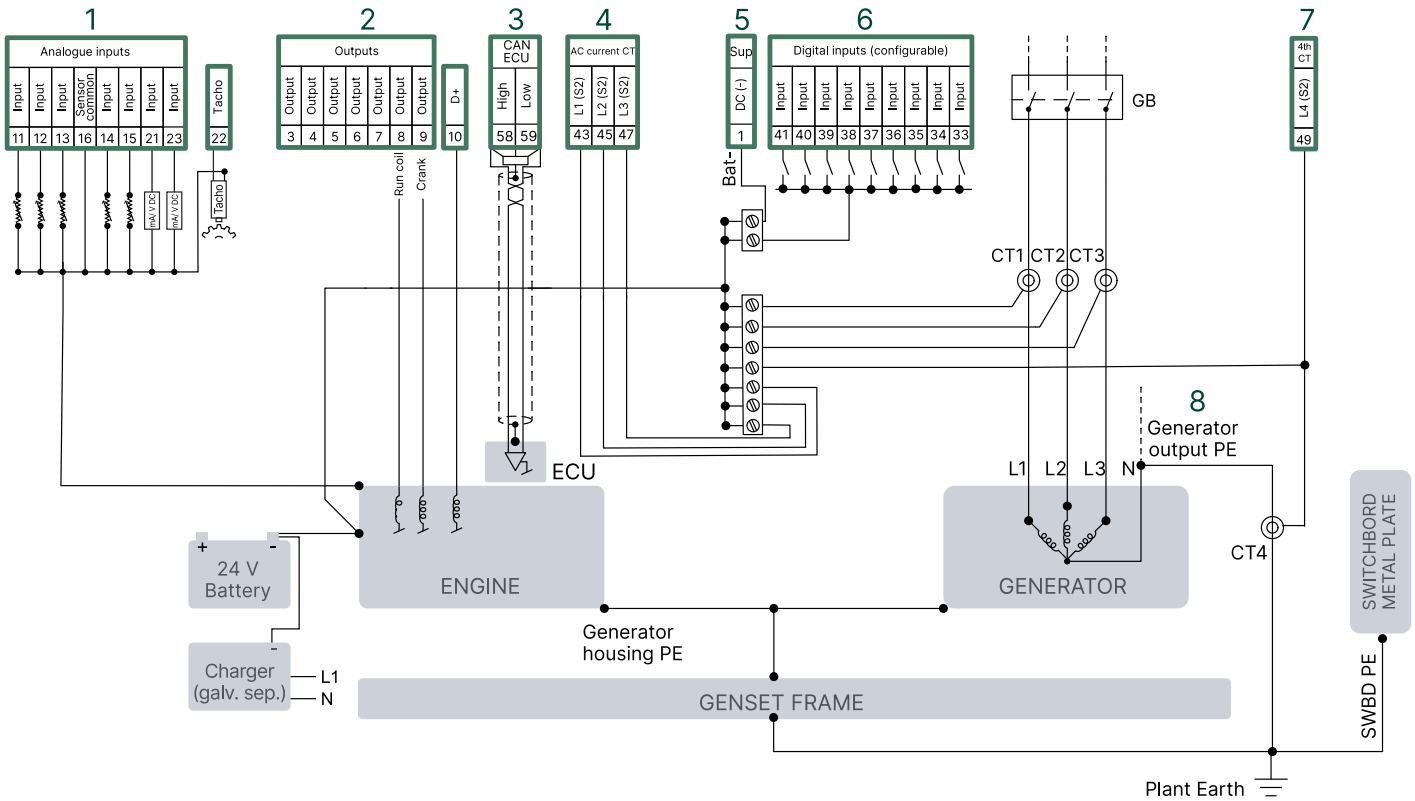

1. Terminal 16 (sensor common point) must be connected to a solidly grounded point on the engine, for example the engine frame. The potential difference to terminal 1 (BAT-) must be less than ± 0.5 V.
2. Do not connect the starter motor relay and the stop solenoid directly to the output terminals on the controller. You can configure each output as run coil and crank.
3. Connect the shield to the engine ECU as described by the engine manufacturer.
4. Current transformers.
5. Power supply DC- (terminal 1) must be connected to BAT- (in this example, the engine).
6. Connect the digital inputs to ground to activate the negative switching.
7. The 4th current is placed on the line from the generator output PE.
8. Connect PE of the generator directly to the plant earth. This prevents short circuits and high energy transients from the grid side to cause severe damage to the system.

3.3 AC connections

Three-phase application (4 wires)

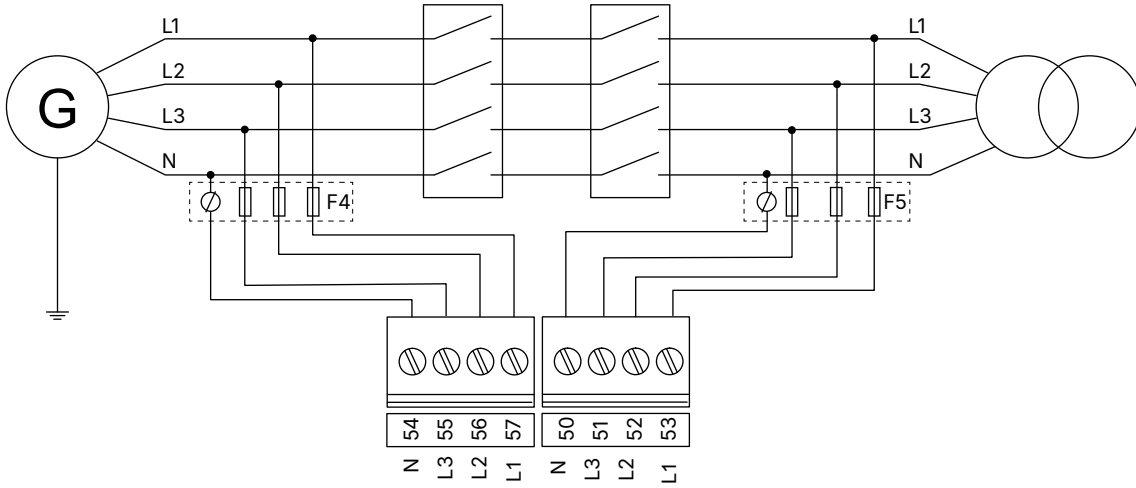

Three-phase application (3 wires)

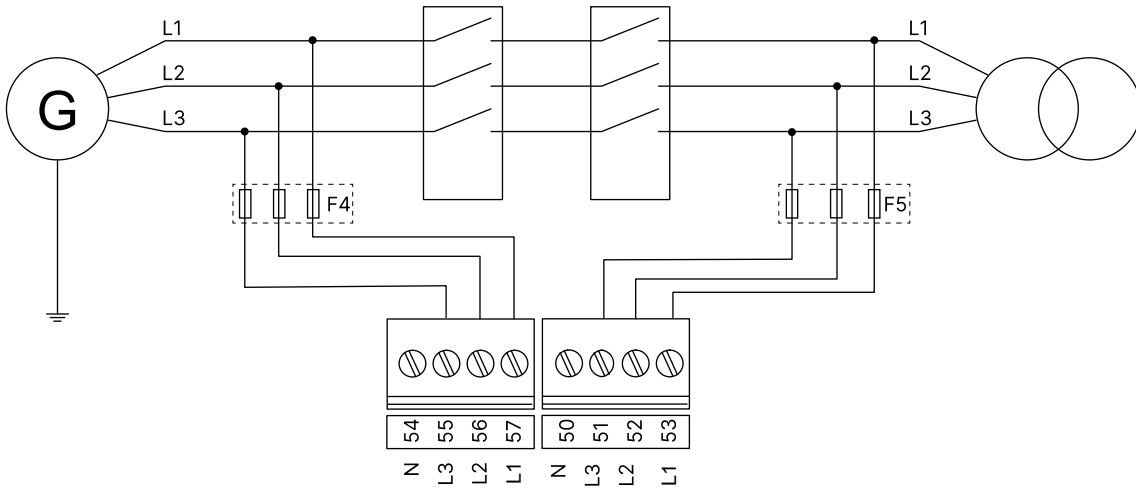

NOTE When three-phase distribution systems are used, the neutral line (N) is only necessary if it is a three-phase + neutral system. If the distribution system is a three-phase system without neutral, then do not connect the terminals 50 and 54.

Two-phase application L1/L2 (3 wires)

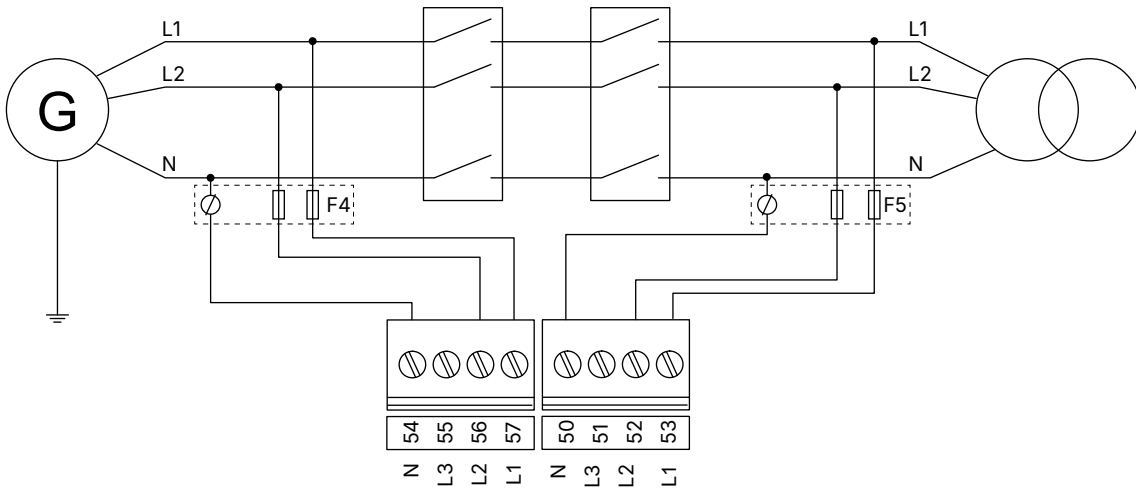

Two-phase application L1/L3 (3 wires)

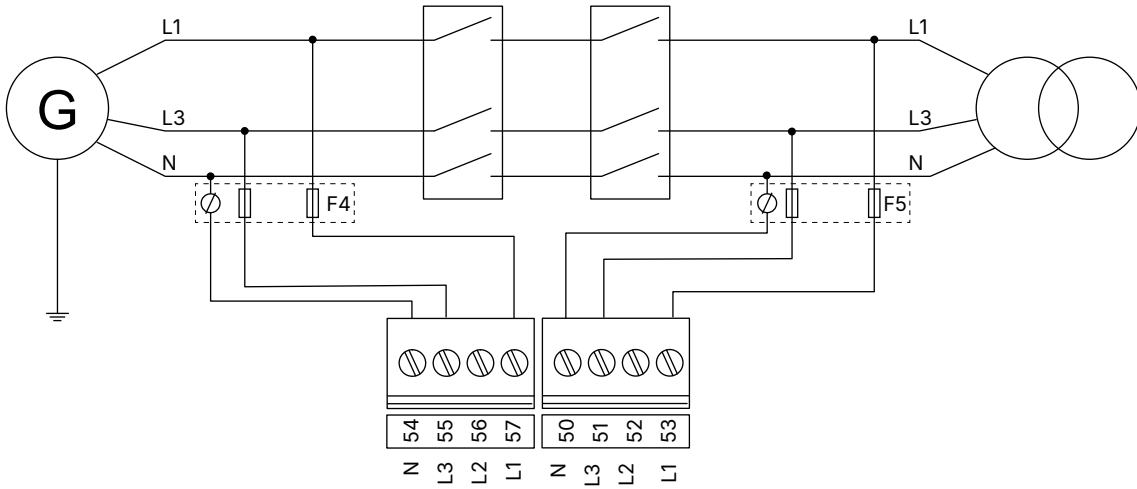

Single-phase application (2 wires)

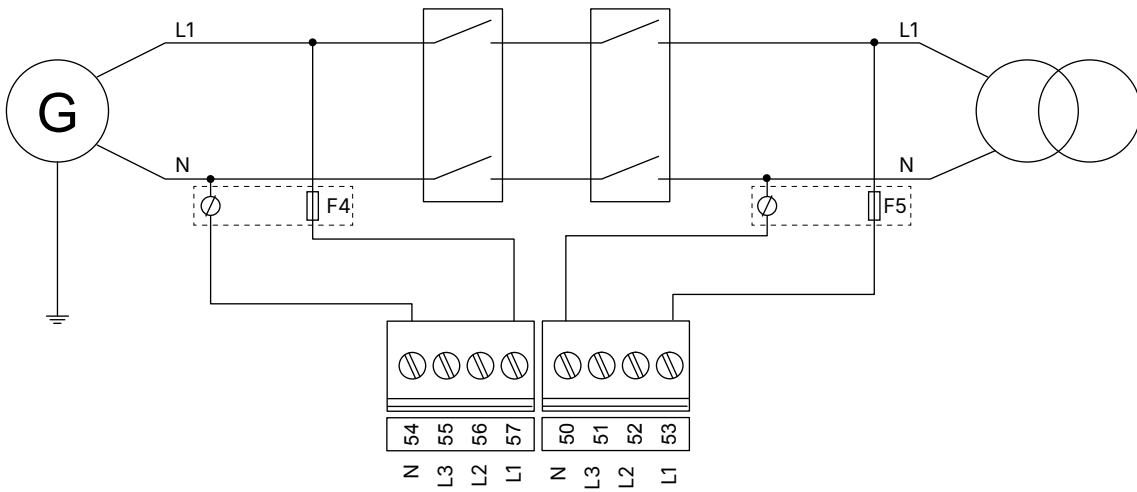

Split phase application L1/L2 (3 wires)

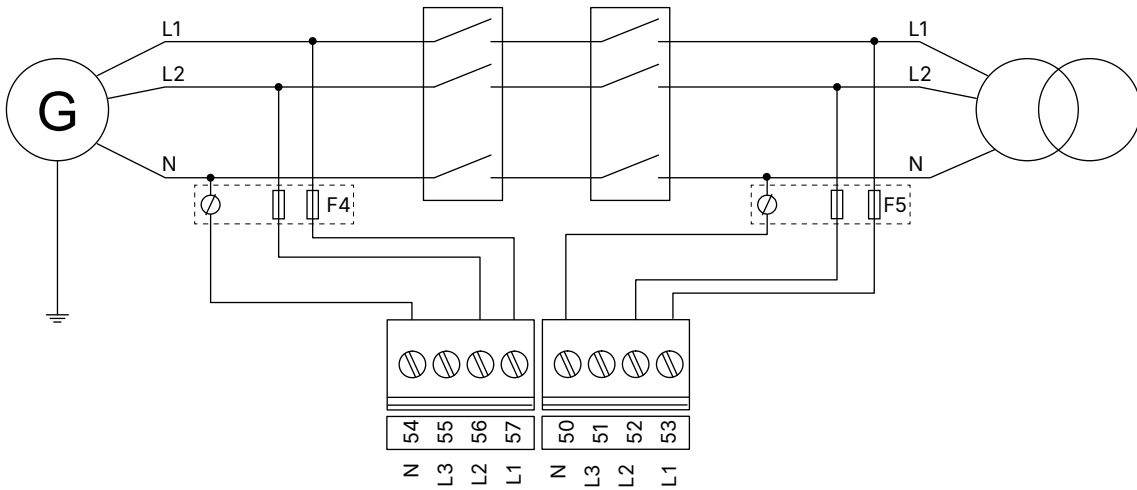

Split phase application L1/L3 (3 wires)

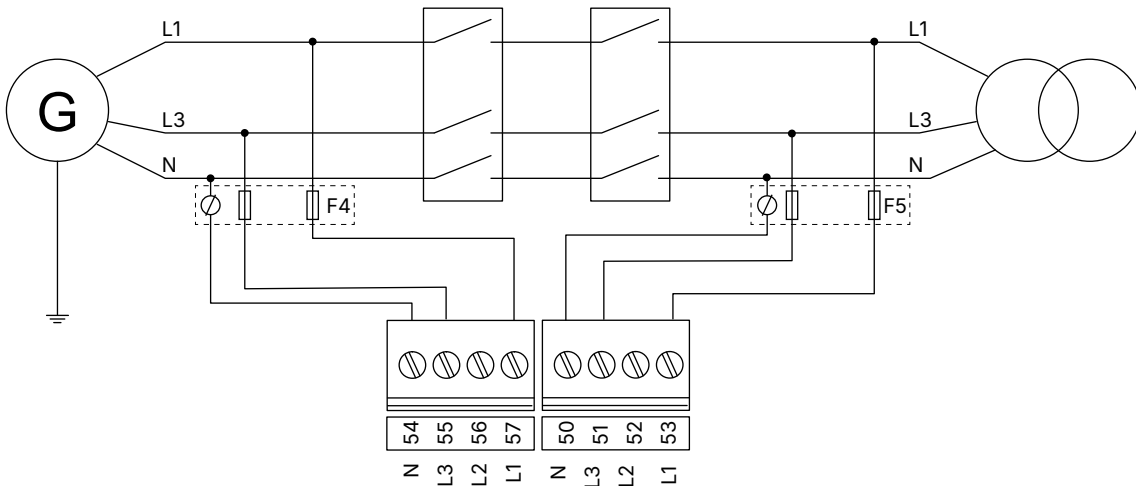

NOTE F4, F5: 2 A AC max. fuse/MCB, c-curve

3.3.1 I4 current

The L4 terminals can be used to measure AC current.

Earth current

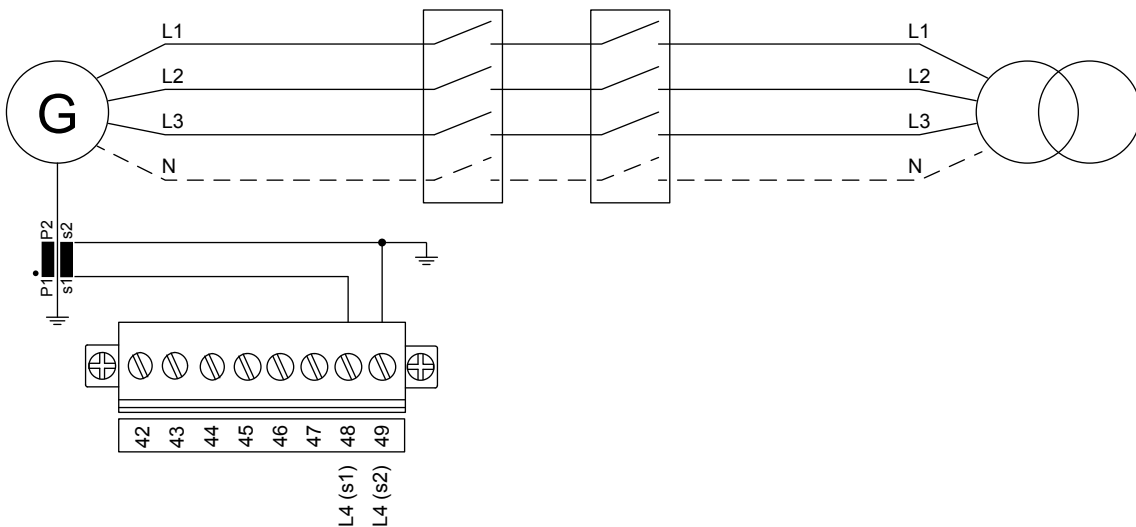

3.3.2 Current transformer (CT) ground

Use one of these methods for the CT ground (S2) connections:

1. The S2 terminals are not grounded. The controller detects the current accurately.
2. The S2 terminals are grounded at the GND terminal (terminal 1).
3. The S2 terminals are grounded but not at the GND terminal. This means that the battery ground (GND terminal) and the CT ground are not the same. The maximum allowable offset between the two ground connections is ± 0.5 V.

NOTE Use the recommended phase sequence when you connect the current transformer (CT).

3.3.3 Voltage measurement fuses

If the wires/cables must be protected with fuses, use max. 2 A time-delay fuses, dependent on the wires/cables to be protected.

3.3.4 Analogue inputs

Analogue input

All sensors must be connected to the Engine GND.

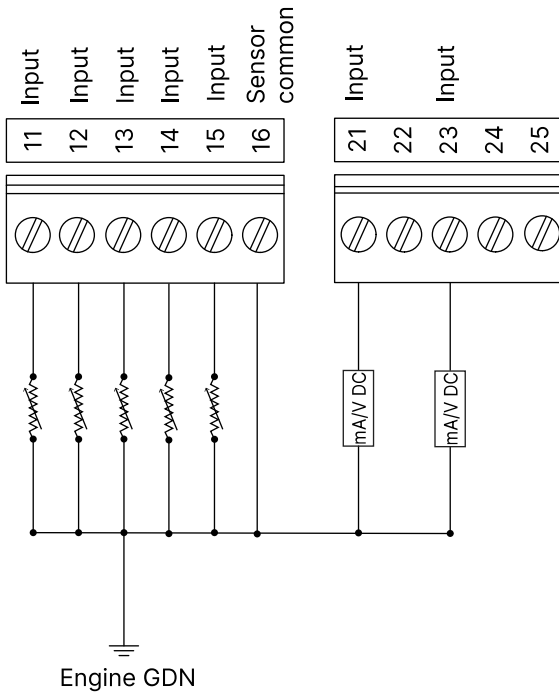

Analogue tacho input (MPU)

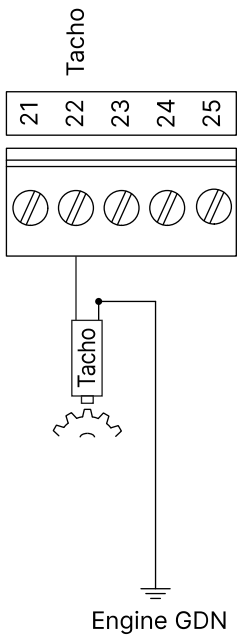

The magnetic pickup (MPU) is an inductive sensor installed on the engine flywheel, and used to detect the engine speed. The output of the MPU is a sine-wave signal.

Resistive sensor inputs

Wiring for the sensor common point (SCP) for analogue inputs 1 to 5 (terminals 11 to 15).

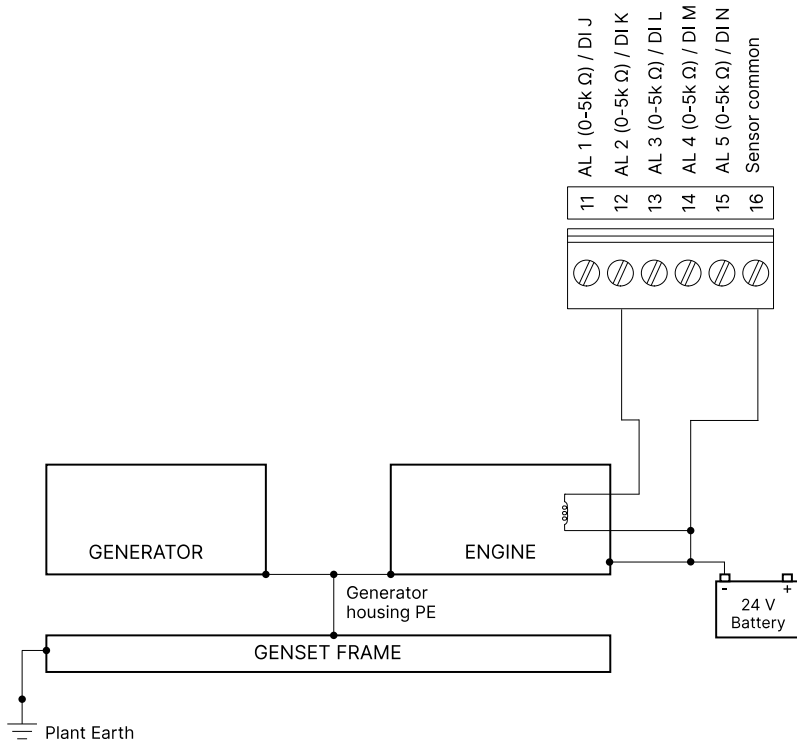

You must connect the terminal 16 (SCP) to a solidly sound point on the engine, for example the engine frame. This point on the engine block is the common reference point for all analogue sensors. Do not share the cable used for this connection with other electrical connections.

Wiring for analogue input 2 (terminal 12) when the input is used as a fuel level sensor.

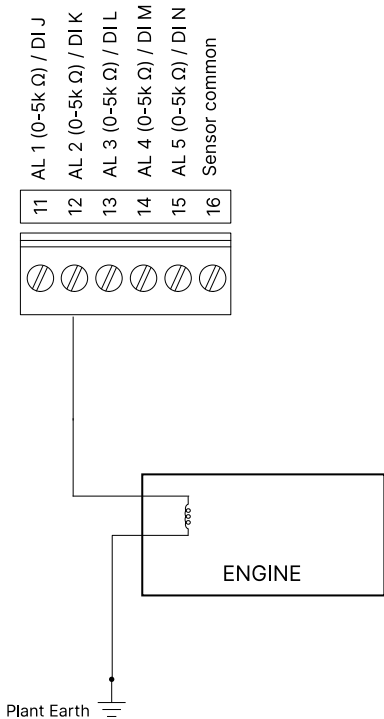

Analogue inputs used as digital inputs

Analogue inputs can be used as digital inputs when wired as shown.

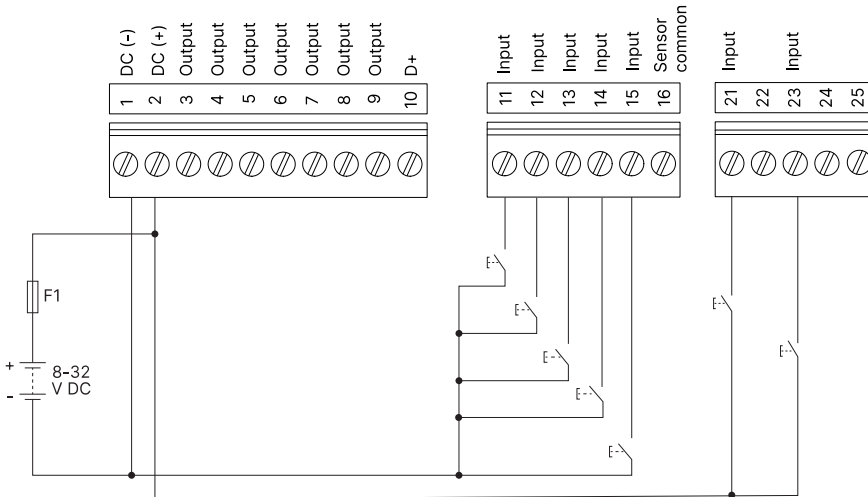

Settings:

- Polarity: Close to activate
- SW state: Not activated
- Logic status: Low

3.4 DC connections

3.4.1 Digital inputs

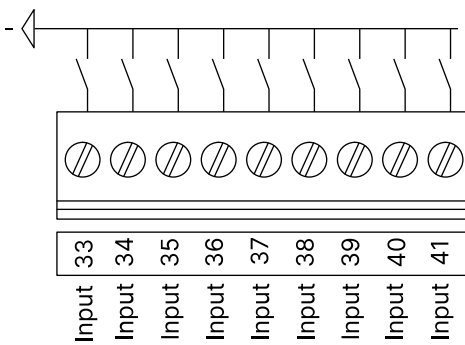

When wiring is more than 10 m, a 4007 diode must be connected on each input.

3.4.2 Digital outputs

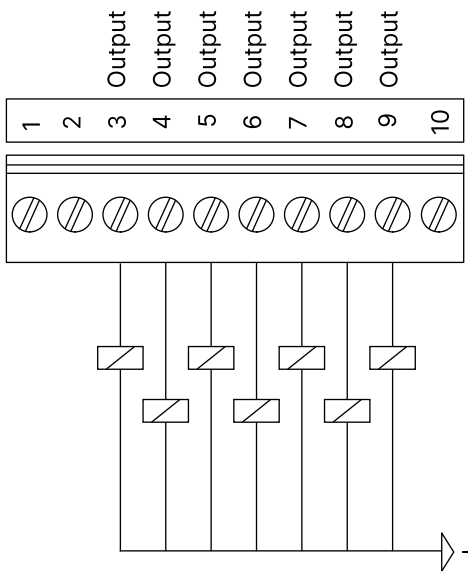

Do not connect the starter motor relay and the stop solenoid directly to the output terminals on the controller.

The current rating is 5 A for terminals 3 and 4, and 1 A for terminals 5, 6, 7, 8, and 9.

NOTE Protect the genset and mains breaker relays against 4 kVA surges as described in IEC-61000-4-5.

3.4.3 Power supply and start

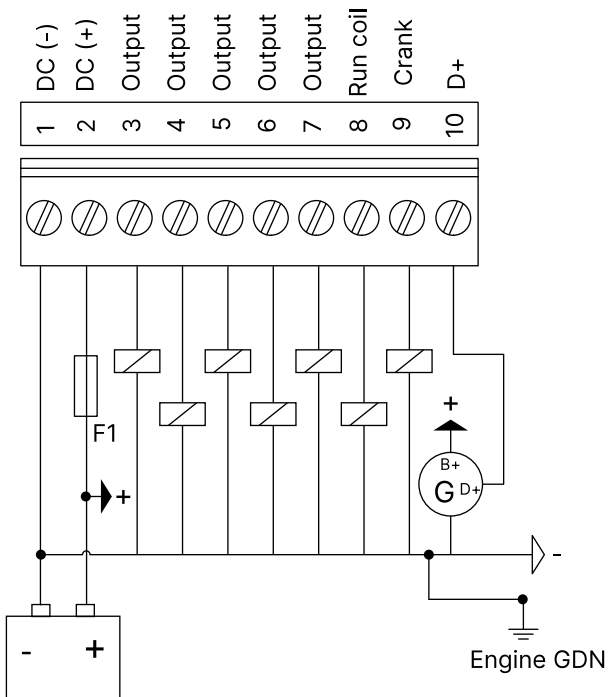

Do not connect the starter motor relay and the stop solenoid directly to the output terminals on the controller.

NOTE Remember to mount the freewheeling diodes.

D+ charger alternator

The charge fail is a combined input and output terminal. When the genset starts, the terminal provides controlled power to excite the charging alternator. The controller monitors the output voltage after excitation. It is possible to configure the action for charge fail.

3.5 Communications

3.5.1 CAN bus engine communication

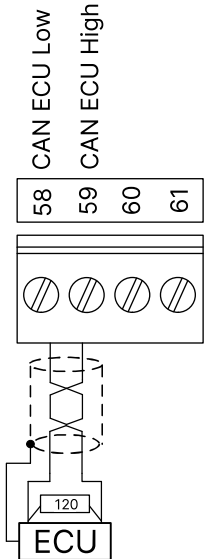

Recommended cable: Belden 3105A or equivalent, 24 AWG (0.5 mm²) twisted pair, shielded, impedance 120 Ω , <40 m Ω /m, min. 95 % shield coverage.

3.5.2 Modbus RS-485

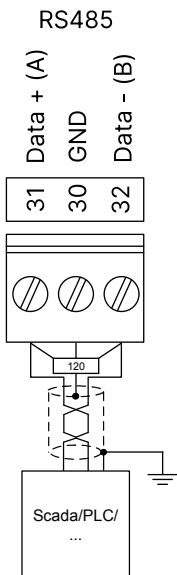

Recommended cable: Belden 3105A or equivalent, 24 AWG (0.5 mm²) twisted pair, shielded, impedance 120 Ω , <40 m Ω /m, min. 95 % shield coverage.

When wiring is more than 10 m, the terminal 30 must be connected to GND.

Example with three SGC controllers connected

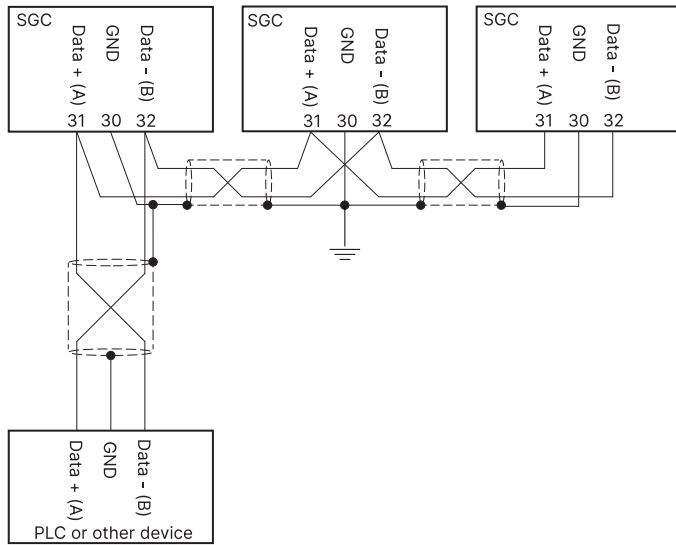

NOTE If there are multiple RS-485 device in the network, then there must be one common ground.

4. Smart Connect Mk II software

4.1 Download the smart connect software

The **SGC Smart Connect Mk II** is the software interface between a PC and the controller. The software is free to download. Download it from www.deif.com

4.2 USB connection

You need a USB cable (USB A to B) to connect the controller to a PC.

1. Install the Smart Connect Mk II software on a PC.
2. Use the USB cable to connect the controller service port to the PC.
3. Start the Smart Connect Mk II software.
4. Select the correct firmware version for your SGC Mk II controller.

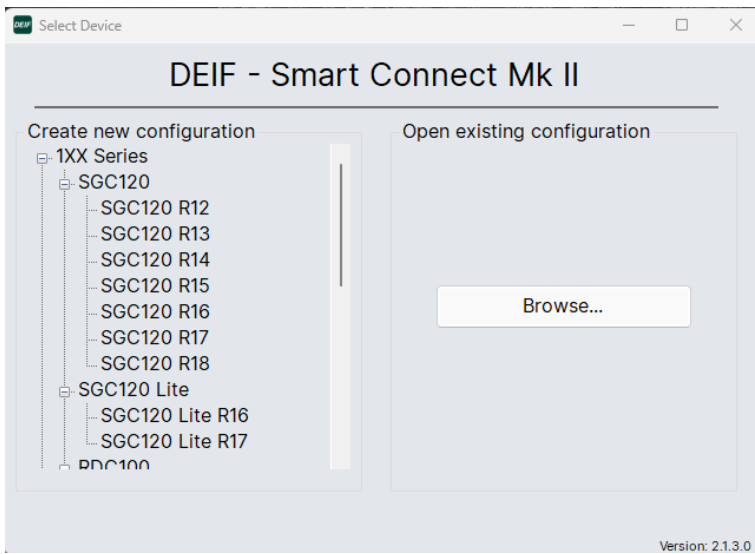

5. You can see the connected device in the bottom left corner of the smart connect screen.

4.3 Smart connect interface

4.3.1 Top toolbar

Configuration

You see this top toolbar when you have selected one of the tabs from the **Select Module** menu.

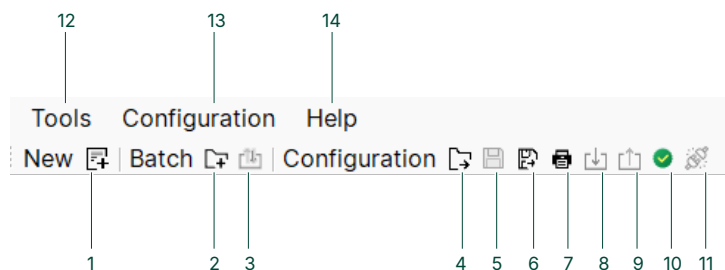

1. New
 - This creates a new smart connect file. All settings and parameters are reset, and your data is not automatically saved.
2. Batch

- This allows you to either open or save the configuration settings, language pack, and M-Logic settings. You can save or open the three setting packages separately or all together. Use to backup the configuration, and restore if necessary.
3. Batch: Read and Write
 - Read or write a batch of setting packages to and from the SGC controller.
 4. Configuration: Open
 - Open a configuration file.
 5. Configuration: Save
 - Save the configuration.
 6. Configuration: Save As
 - Save a copy of the configuration in a user-defined folder.
 7. Configuration: Print
 - Print a PDF version of the configuration.
 8. Read Configuration from device
 - Read the configuration from the SGC Mk II controller.
 9. Write Configuration to device
 - Write the configured configuration to the SGC Mk II controller.
 10. Verify
 - Verify the configuration against the SGC Mk II controller and identify inconsistencies, violations, or missing settings before writing the configuration to the device.
 11. Connect
 - Connect Smart Connect to an SGC Mk II controller.
 12. Tools
 - From the drop-down list, you can create a new smart connect file, read the event logs from the controller, set the time and date on the controller, see device information, update factory profiles, and change the software language.
 13. Configuration
 - From the drop-down list, you can open, save, save as, and print the configuration. You can also read and write the configuration to and from the SGC controller.
 14. Help
 - See an overview of the different modes available. You can also find information about the software in the About section.

Tools drop-down menu

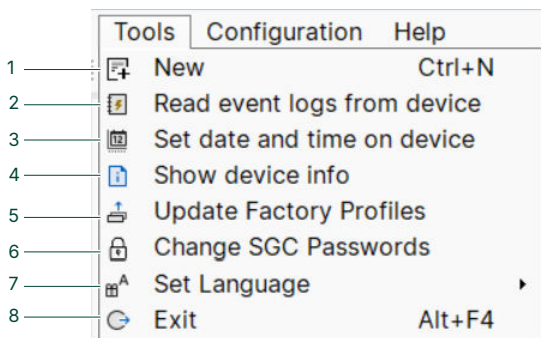

1. New
 - Create a new configuration file.
2. Read event logs from the device
 - Select this to read the event logs that are on the controller.
3. Set the date and time on device
 - Configure the date and time on the SGC controller.
4. Show device info
 - See information about the device.
5. Update Factory Profiles
 - Update the configuration profiles. You can upload new configuration files to the profiles. You can also clear a profile.
6. Change SGC Passwords
 - Change the passwords used to access the SGC controller.
7. Set Language
 - Configure the smart connect language.
8. Exit the smart connect software.

Configuration drop-down menu

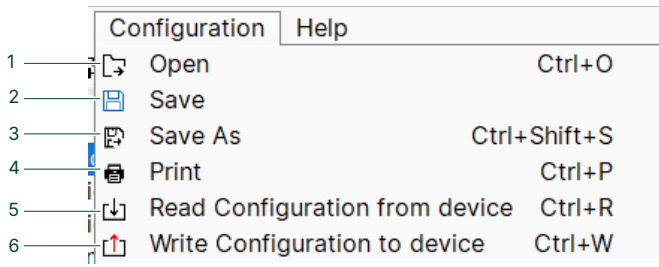

You can only see the configuration drop-down menu when you have selected one of the tabs from the **Select Module** menu.

1. Open
 - Open a new configuration file.
2. Save
 - Save the current configuration.
3. Save as
 - Save the configuration in a user-specific place.
4. Print
 - Print the configuration.
5. Read Configuration from device
 - Read the configuration from the SGC controller. This configuration is then shown in the smart connect software.
6. Write Configuration to device
 - Write the current configuration in the software to the SGC controller.

M-Logic

You see this top toolbar when you have selected **M-Logic** from the **Tools** menu.

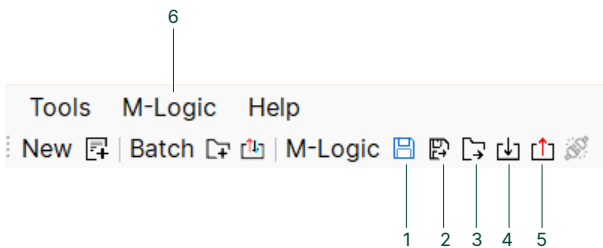

1. Save M-Logic
 - Save the M-Logic configuration.
2. Save M-Logic As
 - Save the M-Logic configuration as a new file.
3. Open M-Logic
 - Open a saved M-Logic file.
4. Read M-Logic from device
 - Read the M-Logic configuration from the SGC controller.
5. Write M-Logic to device
 - Write the M-Logic configuration from the smart connect software to the SGC controller.
6. M-Logic
 - From the drop-down list, you can, for example, save and open an M-Logic file.

M-Logic drop-down menu

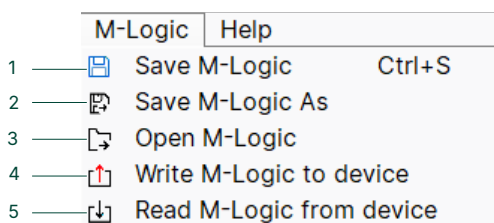

1. Save the current M-Logic configuration.
2. Save the current M-Logic configuration as a new file.
3. Open an M-Logic file.
4. Write the M-Logic configuration from the software to the controller.
5. Read the M-Logic configuration from the controller to the smart connect software.

4.3.2 Left menu

Select Module and Tools

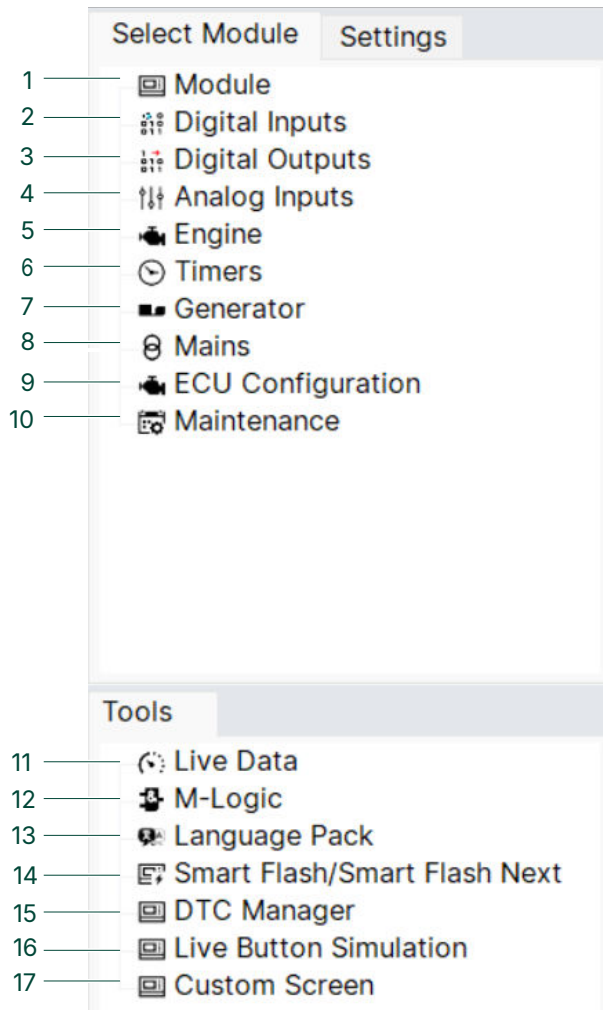

1. Module
 - Configure the settings for the module, for example, the display parameters, sleep mode, and communication.
2. Digital inputs
 - Configure the digital inputs.
3. Digital outputs
 - Configure the digital outputs.
4. Analogue inputs
 - Configure the analogue inputs. You can also add custom sensor curves to the calibration tables.
5. Engine
 - Configure the engine parameters, for example, lube oil pressure, fuel level monitoring, and speed monitoring. See the **Parameters list** for more information about the different parameters.
6. Timers
 - Configure the cranking timers, start/stop timers, and general timers.
7. Generator
 - Configure the generator parameters, for example, voltage, frequency, current, and load monitoring.
8. Mains
 - Configure the mains parameters, for example, voltage and frequency monitoring.
9. ECU Configuration
 - Configure the ECU parameters.
10. Maintenance
 - Configure the maintenance alarm, action, ash load, and due date.
11. Live Data
 - Select the data you want to view live. It is also possible to log and save the data.
12. M-Logic
 - Configure M-Logic. The analogue comparator tool is also available from the M-Logic tab.
13. Language Pack
 - Configure the language for the controller display.
14. Smart flash
 - Update the controller firmware with smart flash.
15. DTC Manager
 - Monitor and manage Diagnostic Trouble Codes (DTCs) received over the CAN bus from ECUs.
16. Live Button Simulation
 - The Live Button Simulation allows you to simulate front-panel buttons and signals digitally from the PC instead of pressing physical buttons or wiring external inputs.

17. Custom Screen

- Design and configure custom display screens for the controller.

Settings

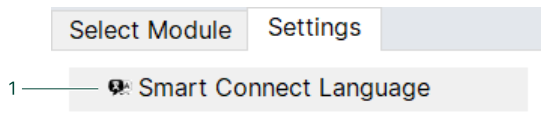

1. Smart Connect Language

- Configure the language for the smart connect software.

4.3.3 Live Simulation Button

Use the Live Button Simulation in the Smart Connect Mk II software to simulate front-panel button operations directly from the PC. This function is typically used during commissioning, testing, and troubleshooting.

NOTE Commands sent using Live Button Simulation are handled by the controller as real commands. Ensure that the installation is in a safe state before sending commands.

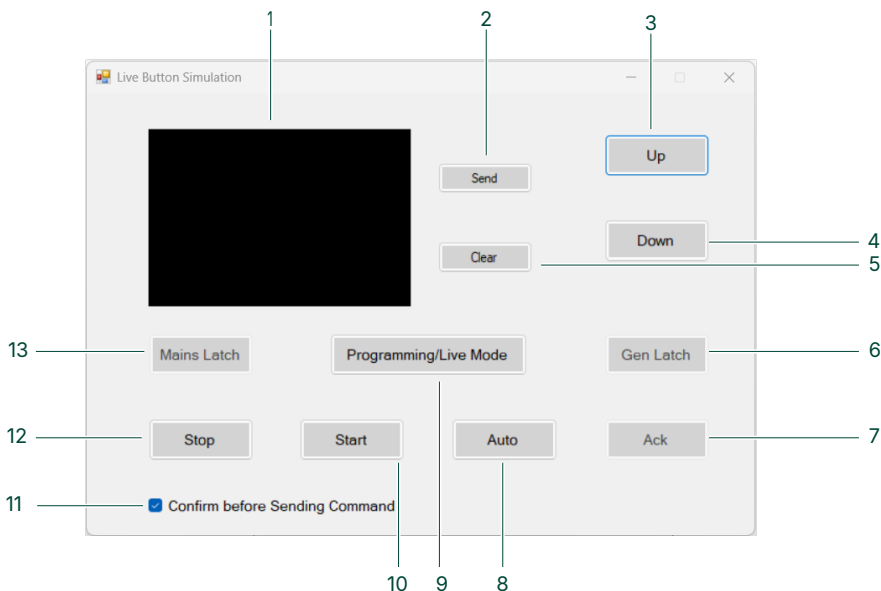

No.	Screen element	Description
1	Command display area	Shows the selected command or simulated front-panel interaction before it is sent to the controller.
2	Send button	Sends the selected command to the controller.
3	Up button	Simulates the Up front-panel button for navigation or increasing values.
4	Down button	Simulates the Down front-panel button for navigation or decreasing values.
5	Clear button	Clears the selected command without sending it to the controller.
6	Gen Latch button	Simulates the generator breaker latch command.
7	Ack button	Simulates the acknowledgment (Ack) front-panel button.
8	Auto button	Simulates selection of Auto operating mode.
9	Start button	Simulates the Start front-panel button.
10	Stop button	Simulates the Stop front-panel button.

No.	Screen element	Description
11	Confirm before Sending Command checkbox	When enabled, requires confirmation before a command is transmitted, helping to prevent unintended operation.
12	Programming/Live Mode selector	Selects whether commands are prepared (Programming) or executed immediately (Live).
13	Mains Latch button	Simulates the mains breaker latch command.





How to use Live Button Simulation

1. Select *Live Button Simulation* from the left toolbar.
2. If required, enable *Confirm before sending command* to avoid unintended operation.
3. Select the required button or command, for example *Start*, *Stop*, *Auto*, or *Ack*.
4. Use *Up* and *Down* to simulate navigation or value changes where applicable.
5. To test breaker functions, select *Gen Latch* or *Mains Latch*.
6. Select *Send* to transmit the selected command to the controller.
7. If required, use *Clear* to remove the selected command without sending it.
8. To execute commands immediately, set the mode to *Live*.

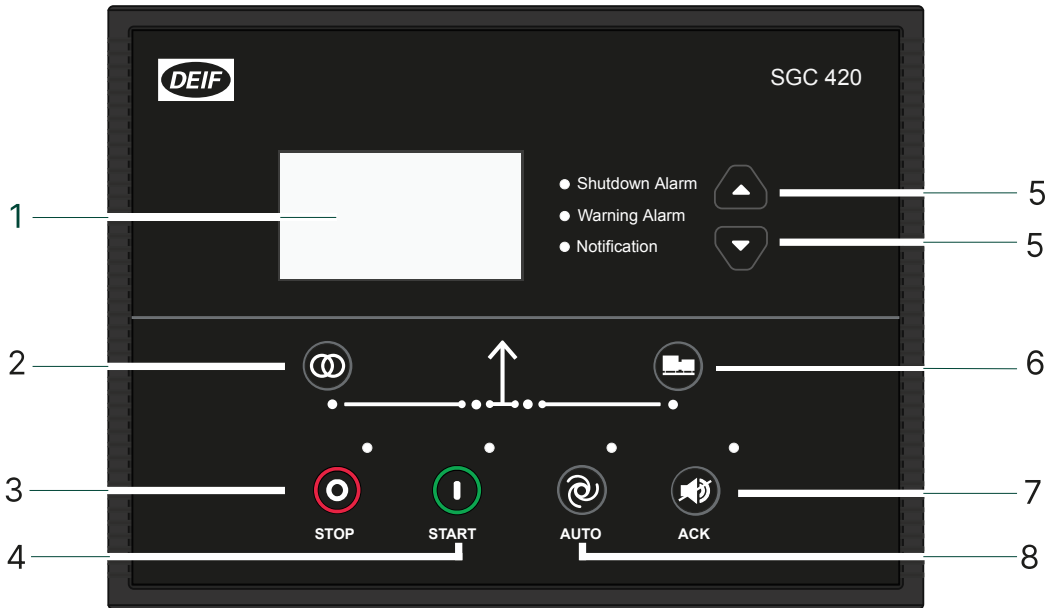
5. Display and menus

5.1 Display, buttons, and LEDs



No.	Name	Function
1	Display	Graphical
2	Mains breaker symbol	Push to open or close the mains breaker.
3	Stop	Stops the genset if MANUAL mode is selected. The controller opens the genset breaker and the cooling down time starts. If you push the Stop  button twice the engine stops immediately.
3	Configure	Push and hold the Stop  button to go to the configuration menu. To exit the menu, push and hold the Stop  button. Push the Start  button to select a parameter, and to save the changes you have made.
4	Start	Starts the genset if MANUAL mode is selected.
5	Navigation	Move the selector up and down on the screen.
6	Genset breaker symbol	Push to open or close the genset breaker.
7	Acknowledge alarm	Push to acknowledge active alarms.
8	AUTO mode/ Mode selection	The controller automatically starts and stops (and connects and disconnects) the genset. No operator actions are needed. The controller also automatically opens and closes the mains breaker. Push the stop button to change the mode to MANUAL mode. To change to test mode, push and hold the AUTO button.

5.2 Mode and menu selection

In the smart connect Mk II software, you can see an overview of how to change the running mode and access the different menus and logs.

Go to [Help > Mode selection in smart connect Mk II](#) to see the overview.

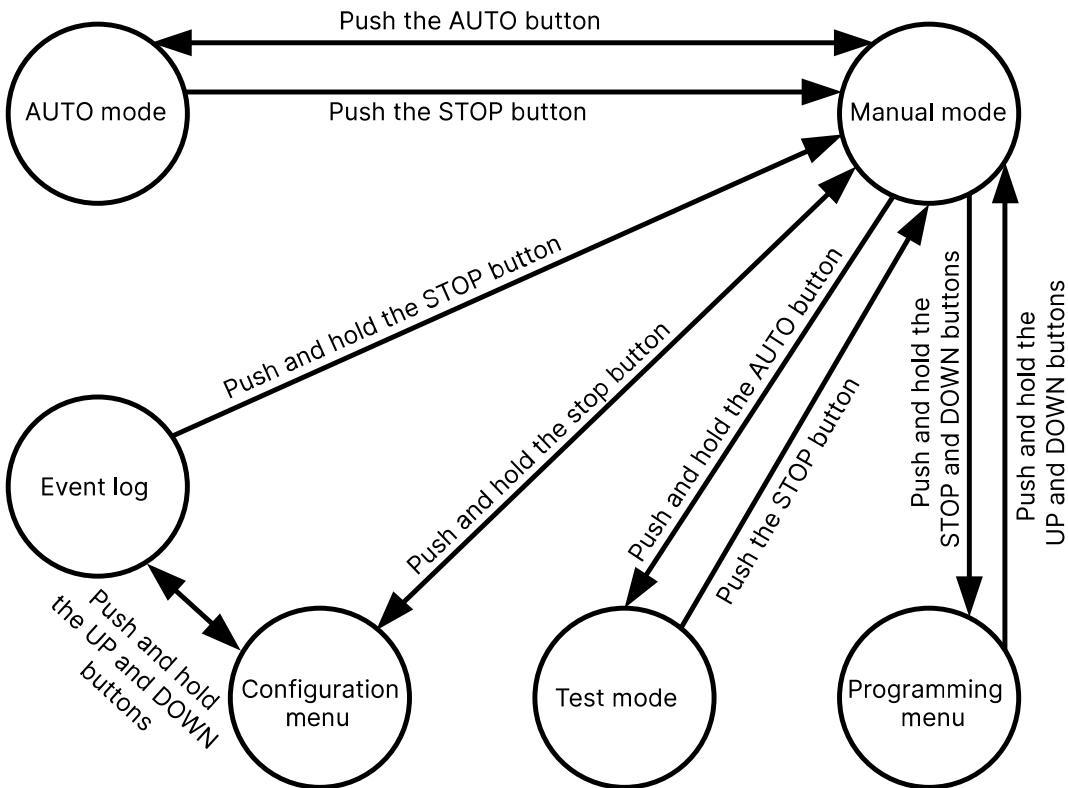

5.3 Display settings

5.3.1 Display

To adjust for ambient lighting, configure the display settings.

Use the smart connect software to configure the contrast in [Module > Display > Contrast](#). You can also configure the time for when the page on the display changes in [Timers > General > Screen Changeover Time](#).



More information

For parameters, see [Display](#) and [General](#).

5.3.2 Power save function

If the power save function is enabled, the controller turns off the backlight after an adjustable timer expires. In the smart connect software, go to [Module > Display](#) to enable the function. To configure the adjustable delay timer, go to [Timers > General > Power Save Mode Delay](#).



More information

For parameters, see [Display](#) and [General](#).

5.3.3 Deep sleep function

You can use the deep sleep function to extend the battery life.





More information

For more information, see [Deep sleep mode](#).



5.4 Monitoring menu

The display views change automatically after an adjustable delay time. You can configure this delay time in the configuration menu.

You can also change the views manually on the controller with the *Up*  and *Down*  buttons.

Examples of display views

	STATUS
Engine off - ready	
Auto	



	ENG TEMP
	35 °C 94 °F

	GEN VOLTAGE
L1 245 V	L1-L2 424 V
L2 245 V 50.0 Hz	L2-L3 427 V
L3 247 V	L1-L3 427 V

	MAINS HEALTHY
L1 244 V	L1-L2 421 V
L2 243 V 49.9 Hz	L2-L3 425 V
L3 248 V	L1-L3 429 V

	AUTO EXERCISE-2
Freq:	Weekly
Next run:	Monday
	At 01:11Hrs
	For 00:23Hrs

	ALARMS	1/1
Fail To Start		

	FUEL LEVEL
	41 % 41 Litres

	HISTOGRAM (%-hr)		
0-20	0:26	61-80	0:02
21-40	0:00	81-100	0:32
41-60	0:24	101+	0:00

5.4.1 Load histogram

The load histogram shows how many running hours the engine has at different load levels. The controller groups the running hours into load ranges so you can monitor how long the genset operates at each load percentage.

The load percentage is calculated using:

- Generator rating (nominal current)
- Measured current

5.4.2 EGR status monitoring

The EGR status monitoring screen provides an overview of the current EGR system condition during operation.

The screen:

- Displays the EGR status.
- Shows the fault timer and heal timer.

This information enables the operator to monitor the EGR condition and follow the progression of fault and recovery states.

Examples of display views

	EGR MON
Status:Egr Ecu Healthy(0)	
Fault Time:	29 Mins
Heal Time:	5 Mins

	EGR MON
Status:Egr Ecu Faulty(1)	
Fault Time:	6 Mins
Heal Time:	0 Mins

	EGR MON
Status:Temp snsr fl(2)	
Fault Time:	22 Mins
Heal Time:	0 Mins

	EGR MON
Status:Temp snsr out(3)	
Fault Time:	50 Mins
Heal Time:	0 Mins

	EGR MON
Status:Vlv wire Open(4)	
Fault Time:	50 Mins
Heal Time:	0 Mins

	EGR MON
Status:Vlv snsr flt(5)	
Fault Time:	15 Mins
Heal Time:	0 Mins

	EGR MON
Status:Vlv NT-Lift/SC(6)	
Fault Time:	49 Mins
Heal Time:	0 Mins

	EGR MON
Status:Vlv nt closing(7)	
Fault Time:	29 Mins
Heal Time:	0 Mins



More information

For more information, see [External EGR monitoring](#).

5.5 Configuration menu

Configure the parameter settings on the display

1. Push and hold the *Stop/Config* button for a minimum of three seconds.
2. Push the *Start* button to continue to the configuration menu.

<p>For Read Mode Press STOP</p> <p>For Write Mode Press START</p>

3. Enter the password. The default password is 0123.
 - Use the *Up* and *Down* buttons to change the number.
 - Select a number with the *Start* button.

PASSWORD
0 ###

4. You can now configure the parameters.
5. To leave the configuration menu, push and hold the *Stop/Config*  button.
6. The controller exits the menu once your settings have been saved.

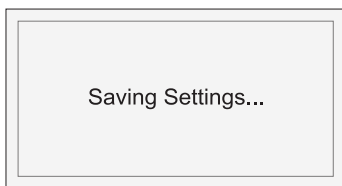

5.5.1 Auto exit config mode

The controller automatically exits the configuration menu when there is no user interaction after an adjustable time. Go to `Timers > General > Auto Exit Config Mode` to configure the timer.

The controller saves all the configuration parameter changes before leaving the menu.

5.6 Parameter list

You need to go to the configuration menu to configure the parameters in the parameter list. A password is needed to enter the menu, and the default is 0123.



More information

See [Configuration menu](#) for how to enter the menu and configure the parameters.

5.6.1 Module

General

Parameter	Range	Default	Description
Name for the configuration set	-	Profile 1	You can change the name of the profile.
Power On mode	Manual Auto	-	The controller operates in this running mode when you power on the controller.
Power On Lamp test	Enabled Not enabled	Not enabled	If this parameter is enabled, the LEDs glow red for 2 seconds after a power reset.
Deep Sleep Mode	Enabled Not enabled	Not enabled	If this parameter is enabled, the controller goes into deep sleep mode when the controller is not in use for an adjustable time.
Load Histogram	Enabled Not enabled	Not enabled	The load histogram shows the engine running hours. The running hours are put into load groups.
Auto-Clear Warning Alarm	Enabled Not enabled	Not enabled	If this parameter is enabled, the controller automatically clears an active alarm, when you have resolved the condition that activated the alarm.

Display

Parameter	Range	Default	Description
Contrast	0 to 100 %	80 %	Configure the display contrast with this parameter.
Power Save Mode	Enabled Not enabled	Not enabled	If this parameter is enabled, the controller turns off the LCD backlight after an adjustable time. This is only when the engine is not operating. You can configure the adjustable timer on the controller or with the smart connect software here : Timers > General > Power Save Mode Delay.
Filter Enable	Enabled Not enabled	Not enabled	Enable this parameter to configure the display voltage filter.
Filter Constant	0 to 99	50	Configure the filter constant for the display voltage filter.

Communication

Parameter	Range	Default	Description
Communication Mode	None MODBUS	None	Select the communication mode.
Slave ID	1 to 247	2	Select the server ID for Modbus.
Baud rate	1200 bps 2400 bps 4800 bps 9600 bps 19200 bps 38400 bps 57600 bps 115200 bps	9600 bps	Select the baud rate for the serial communication.
Parity Bit	None Even Odd	None	Select the parity bit for the serial communication.

Site Battery Monitoring

Parameter	Range	Default	Description
Battery Monitoring	Enabled Not enabled	Not enabled	If this parameter is enabled, the controller monitors the site battery voltage. The voltage is also shown on the controller.
Low Voltage Threshold	12.0 to 60.0 V	60.0 V	This is the set point for the site battery voltage. If the voltage is less than this set point, there is a battery failure.
Battery Monitoring Delay	5 to 300 s	20 s	This is the delay timer for the site battery voltage. If the voltage is still low when the timer expires, there is a battery failure.
Genset Run Duration	1 to 720 minutes	270 minutes	During a site battery failure, the genset operates for the <i>Genset Run</i> duration. This is only for AUTO mode.

Cyclic Mode

Parameter	Range	Default	Description
Cyclic Mode	Enabled Not enabled	Not enabled	If you enable this parameter, the controller operates in cyclic mode.
Genset Off Time	1 to 720 minutes	15 minutes	Select the time duration for when the genset is not operating.
Genset On Time	1 to 720 minutes	15 minutes	Select the time duration for when the genset is operating.

Auto Exercise 1

Parameter	Range	Default	Description
Auto Exercise	Enabled Not enabled	Not enabled	If you enable this parameter, the controller operates in exercise mode for the adjustable time duration.
Event Occurrence	Daily Weekly Monthly	Daily	Configure how often the sequences occur.
Event Day	Daily: Runs every day Weekly: Sunday to Saturday Monthly: 1 to 28	Runs Everyday	Configure the start date for the sequences.
Start Time	00:00 to 23:59 hour	10:00 hour	Configure the start time for the sequences.
Duration	00:01 to 99:59 hour	10:10 hour	Configure for how long the genset operates during the scheduled sequences.
Load Transfer	Enabled Not enabled	Not enabled	If this parameter is enabled, the load is on the genset. If this parameter is not enabled, the load is transferred from the genset to the mains. This is not possible during a mains failure.

Auto Exercise 2

Parameter	Range	Default	Description
Auto Exercise	Enabled Not enabled	Not enabled	If you enable this parameter, the controller operates in exercise mode for the adjustable time duration.
Event Occurrence	Daily Weekly Monthly	Daily	Configure how often the sequences occur.
Event Day	Daily: Runs every day Weekly: Sunday to Saturday Monthly: 1 to 28	Runs Everyday	Configure the start date for the sequences.
Start Time	00:00 to 23:59 hour	09:59 hour	Configure the start time for the sequences.
Duration	00:01 to 99:59 hour	10:10 hour	Configure for how long the genset operates during the scheduled sequences.
Load Transfer	Enabled Not enabled	Not enabled	If this parameter is enabled, the load is on the genset. If this parameter is not enabled, the load is transferred from the genset to the mains. This is not possible during a mains failure.

Night Mode

Parameter	Range	Default	Description
Night Mode	Enabled Not enabled	Not enabled	In this mode, the controller is off until the night mode timer expires. You can configure when night mode is active.
Night Mode Start Time	00:00 to 23:59 hour	00:09 hour	The night mode is activated, when the start timer starts.
Night Mode Off Duration	1 to 1440 minutes	10 minutes	Night mode is active until the <i>Night Mode Off</i> timer expires.

5.6.2 Digital inputs

Digital Input [A to P]

Parameter	Range	Default	Description
Source	See Digital input source selection in this document	Not used	Select an input source from the list.
Dig In [A to P]	You can customise the digital input name.		
Polarity	Close to Activate Open to Activate	Close to Activate	You can select how to activate the input. It can be open or close with reference to ground.
Action	None Notification Warning Electrical Trip Shutdown	None	You can configure what action occurs when the digital input is activated.
Activation	Never From Engine Start From Monitoring On Always	Always	You can configure when the controller starts to monitor the digital input.
Activation Delay	0 to 60 s	1 s	When the timer expires, the configured action occurs.

5.6.3 Digital outputs

Digital outputs [A to G]

Parameter	Range	Default	Description
Source	See Digital output source selection in this document	Disable	Select an output source from the list.
Polarity	Energise De-energise	Energise	Select what the status of the output source is when it is active. You can select if it is energised or de-energised.

5.6.4 Analogue inputs

Analogue Input [1 to 7]

Parameter	Range	Default	Description
Use Input As	Not used Digital input [J to P] Lube oil pressure Fuel level sensor	Not used	Select the input.

Parameter	Range	Default	Description
	Engine coolant temperature Shelter temperature sensor Custom sensor [1 to 7]		
Calibration Table	X-axis: Resistance: 0 to 5000 Ω Y-axis: Pressure: 0.0 to 99.0 Bar (Engine) Temperature: -25 to 300 °C Fuel level: 0 to 100 % Custom value: -3000 to 3000	-	Configure the x and y values for the 10 measurement points in the calibration table.

5.6.5 Engine

Crank Disconnect

Parameter	Range	Default	Description
Start Attempts	1 to 9	3	Number of attempts to crank the engine.
Disconnect on Oil Pressure Sensor	Enabled Not enabled	Not enabled	If this parameter is enabled, the crank is disconnected when the oil pressure is more than the oil pressure set point (DISCONN LOP SENS).
Monitor Pressure Sensor Before Crank	Enabled Not enabled	Not enabled	If this parameter is enabled, the oil pressure is monitored before the engine starts. If the oil pressure is more than the set point (MON LOP BEF CRANK), the engine cannot start.
Pressure Sensor Monitoring Threshold	0.5 to 10.0 bar	4.0 bar	Configure the set point for the oil pressure.
Monitor Pressure Switch Before Crank	Enabled Not enabled	Not enabled	If this parameter is enabled, the oil pressure is monitored before the engine starts. If the pressure switch is open, the controller activates a high oil pressure alarm.
Disconnect on Oil Pressure Switch	Enabled Not enabled	Not enabled	If this parameter is enabled, the crank disconnects if the oil pressure is high.
Pressure Switch Transient Time	0.0 to 3.0 s	1.5 s	If the oil pressure is high after this timer expires, the crank is disconnected.
Crank Disconnect At Alt Frequency	10 to 70 Hz	20 Hz	If the frequency is more than this set point during cranking, the controller disconnects the crank.
Crank Disconnect At Engine Speed	150 to 4000 RPM	600 RPM	If the engine speed is more than this set point during cranking, the controller disconnects the crank.
Disconnect On Charging Alt Voltage	Enabled Not enabled	Not enabled	If this parameter is enabled, the crank is disconnected when the charging alternator voltage is more than the alternator set point

Parameter	Range	Default	Description
			(CHG ALT THRESHOLD) during a cranking attempt.
Charging Alt Disconnect Volt Threshold	5.0 to 30.0 V	5.0 V	If the charging alternator voltage is more than this set point during cranking, the crank is disconnected.

Preheat

Parameter	Range	Default	Description
Pre-heat Timer	1 to 900 s	10 s	When the pre-heat timer expires, the engine starts to crank.
Engine Coolant Temperature	Enabled Not enabled	Not enabled	If this parameter is enabled, the pre-heat output is deactivated when the engine coolant temperature is more than the set point for the coolant temperature (ENG TEMP LIMIT).
Engine Coolant Temp Threshold	10 to 300 °C	25 °C	The set point for the engine coolant temperature.

Speed Monitoring

Parameter	Range	Default	Description
Engine Speed Sense Source	Alternator frequency Magnetic Pickup W-Point Frequency	Alternator frequency	Configure how engine speed is monitored.
Flywheel Teeth (Magnetic Pickup)	1 to 300	110	The number of teeth on the flywheel.
W-Point Frequency@1500	0 to 500	274	The frequency at the w-point of the charging alternator.
Under-speed Shutdown	Enabled Not enabled	Not enabled	If this parameter is enabled, the controller shuts down the engine when the speed is less than the configured set point for under-speed.
Under-speed Threshold	0 to 100 %	90 %	When the speed is less than this set point, the controller shuts down the engine.
Under-speed Delay	1 to 60 s	3 s	If the speed is still less than the under-speed set point when the timer expires, the engine shuts down.
Over-speed Threshold	100 to 200 %	110 %	The set point for over-speed.
Over-speed Delay	1 to 20 s	3 s	If the speed is still more than the over-speed set point when the timer expires, the controller activates an alarm.
Gross Over-speed Threshold	100 to 200 %	130 %	If the speed is more than this set point, the engine shuts down. The percentage is of the nominal speed.
Initial Low Speed	500 to 1800 RPM	600 RPM	Use this parameter to reduce the amount of pollution when the engine starts. This is the initial speed of the engine, and is lower than the operating speed.
Idle to Rated Delay Time	0 to 1200 s	10 s	Time for the engine to go from idle speed to rated speed.

Parameter	Range	Default	Description
Start-up Idle Mode Time	0 to 1200 s	0 s	The engine operates at low speed for this time duration. You can configure the low speed with the <i>Initial Low Speed</i> parameter.
Stopping Idle Time	0 to 1200 s	0 s	In idle mode, the engine operates at low speed for this time duration before the engine shuts down.
Idle Mode Pulse Time	0 to 60 s	2 s	The pulse time for the idle mode output.

Battery Monitoring

Parameter	Range	Default	Description
Low Battery Voltage Action	None Notification Warning Electrical Trip Shutdown	None	Configure the action for when the battery voltage is low.
Low Battery Voltage Threshold	8.0 to 31.0 V	8.0 V	The action for low battery voltage is activated when the voltage load is less than this set point.
Low Battery Voltage Delay	5 to 1800 s	30 s	If the battery voltage is less than the low voltage set point (LOW VOLT THRESHOLD) when the timer expires, the controller activates the action for low battery voltage.
High Battery Voltage Action	None Notification Warning Electrical Trip Shutdown	None	Configure the action for when the battery voltage is high.
High Battery Voltage Threshold	9.0 to 32.0 V	15.0 V	The action for high battery voltage is activated when the voltage load is more than this set point.
High Battery Voltage Delay	5 to 1800 s	10 s	If the battery voltage is more than the set point for high voltage (HIGH VOLT THRESHOLD) when the timer expires, the controller activates the action for high battery voltage.

Lube Oil Pressure (LOP)

Parameter	Range	Default	Description
Shutdown	Enabled Not enabled	Not enabled	If this parameter is enabled, the controller shuts down the engine when the lube oil pressure is less than the shutdown set point (Shutdown Threshold).
Shutdown Threshold	0.0 to 96.8 Bar	2.0 Bar	If the lube oil pressure is less than this set point, the controller shuts down the engine.
Warning	Enabled Not enabled	Not enabled	If this parameter is enabled, the controller activates a warning alarm when the lube oil pressure is less than the warning set point (Warning Threshold).
Threshold	0.2 to 99.0 Bar	3.0 Bar	If the lube oil pressure is more than this set point, the controller activates a warning alarm.
LOP Sensor Reference	Engine Body	Engine Body	Configure the reference point for the sensor.

Parameter	Range	Default	Description
	Battery Negative		
Circuit Fault Action	None Warning Notification Electric Trip Shutdown	None	Configure the action for a circuit failure.

Fuel Level Monitoring

Parameter	Range	Default	Description
Low Fuel Level Shutdown	Enabled Not enabled	Not enabled	If this parameter is enabled, the controller shuts down the engine when the fuel level is less than the shutdown set point.
Shutdown Threshold	0 to 78 %	10 %	If the oil level is less than this set point, the controller shuts down the engine.
Low Fuel Level Warning	Enabled Not enabled	Not enabled	If this parameter is enabled, the controller activates a warning alarm when the oil level is less than the warning set point.
Warning Threshold	2 to 80 %	12 %	If the oil level is less than this set point, the controller activates a warning alarm.
Fuel Tank Capacity	0 to 6000 l	100 l	Configure the capacity of the fuel tank.
Fuel Theft Warning	Enabled Not enabled	Enabled	If the rate of fuel removal is more than the set point for the fuel theft alarm, the controller activates a warning alarm.
Fuel Theft Alarm Threshold	1 to 100 %/hour	50 %/hour	The set point for the rate of fuel removal. If the rate is more than this set point, the controller activates the warning alarm.
Circuit Fault Action	None Notification Warning Electric trip Shutdown	None	The action for a circuit failure.
Fuel Sensor Reference	Engine Body Battery Negative	Engine Body	The reference point for the fuel sensor.

Engine Coolant Temperature

Parameter	Range	Default	Description
Shutdown	Enabled Not enabled	Not enabled	If this parameter is enabled, the controller shuts down the engine when the engine coolant temperature is more than/less than the shutdown set point.
Shutdown Threshold	27 to 300 °C	27 °C	If the coolant temperature is more than/less than this set point, the controller shuts down the engine.
Warning	Enabled Not enabled	Not enabled	If this parameter is enabled, the controller activates a warning alarm when the coolant temperature is more than/less than the warning set point.
Warning Threshold	25 to 298 °C	25 °C	If the coolant temperature is more than/less than this set point, the controller activates a warning alarm.

Parameter	Range	Default	Description
Temp. Threshold Type	Greater Than Threshold Less Than Threshold	Greater Than Threshold	Configure if the controller activates a shutdown and/or a warning when the coolant temperature is less than or more than the set points.
Engine Coolant Temp. Sensor Reference	Engine Body Battery Negative	Engine Body	The reference point for the coolant temperature sensor.
Circuit Fault Action	None Notification Warning Electric trip Shutdown	None	The action for a circuit failure.

Shelter Temperature Sensor

Parameter	Range	Default	Description
High Temp Threshold	25 to 300 °C	60 °C	The set point for a high shelter temperature. If the shelter temperature is more than this set point, the genset is started, and takes the load.
Shelter Temp Hysteresis	1 to 100 °C	5 °C	The shelter temperature hysteresis value. If the shelter temperature hysteresis is less than this set point when the genset operates, the controller stops the genset. This is only if the battery voltage is OK and there is a mains failure.
Shelt temp Monitoring Delay	5 to 600 s	300 s	If the shelter temperature is more than the set point when the timer expires, the controller starts the genset start sequence.
Shelt Temp Run Duration	1 to 720 min	60 min	In AUTO mode, the genset operates for this time duration when the shelter temperature is more than the high temperature set point.
Shelter Temp Sensor Reference	Engine Body Battery Negative	Engine Body	The reference point for the coolant temperature sensor.
Shelter Temp Fault Action	None Notification Warning Electric trip Shutdown	None	The action for a shelter temperature failure.

Coolant Temperature Control

Parameter	Range	Default	Description
Enable	Enabled Not enabled	Not enabled	Enable this parameter to configure coolant control.
Temperature Control	Heater Control Cooler Control	Heater Control	Select the type of coolant control.
ON Threshold	0 to 250 °C	49 °C	Cooler control: If the cooler temperature is more than the ON threshold, the output for <i>Coolant Temperature Control</i> is activated. Heater control: If the heater temperature is less than the ON threshold, the output for <i>Coolant Temperature Control</i> is activated.
OFF Threshold	0 to 250 °C	50 °C	Cooler control: If the cooler temperature is less than the OFF threshold, the output for <i>Coolant Temperature Control</i> is deactivated.

Parameter	Range	Default	Description
			Heater control: If the heater temperature is more than the OFF threshold, the output for <i>Coolant Temperature Control</i> is deactivated.

Charging Alternator

Parameter	Range	Default	Description
Charging Alternator Fail Action	None Notification Warning Electrical Trip Shutdown	None	Configure the action for charging alternator failure.
Charging Alternator Fail Threshold	0.0 to 35.0 V	10.0 V	The action for charging alternator failure is activated when the alternator voltage is more than this set point.
Charging Alternator Fail Delay	5 to 60 s	10 s	If the alternator voltage is more than the set point for high voltage (FAIL THRESHOLD) when the timer expires, the controller activates the action for charging alternator failure.

Automatic Fuel Transfer (AFT)

Parameter	Range	Default	Description
AFT Activation Threshold	0 to 99 %	40 %	If the fuel level is less than this threshold, the auto fuel transfer output is activated.
AFT e-activation Threshold	1 to 100 %	80 %	If the fuel level is more than this threshold, the output for auto fuel transfer is deactivated.
Timeout After Activation	1 to 1200 s	600 s	If the fuel level is less than the deactivation threshold when this timer expires, the controller activates a timeout alarm and deactivates the fuel transfer output.
Monitor AFT From Engine On	Enabled Not enabled	Not enabled	If this parameter is enabled, the controller monitors the fuel level when the engine is running.

Custom Sensor [1 to 7]

Parameter	Range	Default	Description
Custom Sensor # Name	-	-	Name of the sensor. This is configurable.
Shutdown	Enabled Not enabled	Not enabled	If this parameter is enabled, the controller shuts down the engine when the monitored value is less than or more than the shutdown set point.
Shutdown Threshold	-3000.0 to 2999.9	2.0	If the monitored value is more than or less than this set point, the controller shuts down the engine.
Warning	Enabled Not enabled	Not enabled	If this parameter is enabled, the controller activates a warning alarm when the monitored value is less than or more than the shutdown set point.
Warning Threshold	-2999.9 to 3000.0	3.0	If the monitored value is more than or less than this set point, the controller activates a warning alarm.

Parameter	Range	Default	Description
Threshold Type	Greater Than Threshold Less Than Threshold	Less Than Threshold	Configure if the controller activates a shutdown and/or a warning when the coolant temperature is less than or more than the set points.
A[1 to 7] Sensor Reference	Engine Body Battery Negative	Engine Body	The reference point for the coolant temperature sensor.
Activation	Never From Engine Start From Monitoring On Always	From Monitoring On	If this parameter is enabled, the controller defines when the monitored sensor becomes active.
Activation Delay	0 to 60 s	1 s	When this timer expires, the controller activates monitoring of the sensor.
Circuit Fault Action	None Notification Warning Electric trip Shutdown	None	The action for a circuit failure.

5.6.6 Timers

Cranking

Parameter	Range	Default	Description
Crank Hold Time	1 to 255 s	5 s	Configure for how long the engine cranks.
Crank Rest Time	2 to 60 s	5 s	The time between each crank.
Manual Start Delay	0 to 300 s	3 s	When this timer expires in manual mode, the engine starts to crank.
Auto Start Delay	0 to 43200 s	3 s	When this timer expires in AUTO mode, the engine starts to crank.
Run coil time	0.0 to 900.0 s	1.0 s	The run coil timer.

Start/Stop

Parameter	Range	Default	Description
Safety Monitoring Delay	5 to 60 s	5 s	The engine safety parameters are not monitored during the <i>Safety monitoring delay</i> . The timer starts after crank disconnect.
Warm-Up Delay	0 to 60 s	3 s	When the alternator voltage and frequency are OK, the load is transferred to the alternator. There's a <i>warm-up delay</i> before the load is transferred.
Return To Mains Delay	0 to 600 s	5 s	The controller closes the mains breaker when the <i>return to mains delay</i> timer expires.
Engine Cooling Time	0 to 300 s	5 s	When the <i>engine cooling</i> timer expires, the engine stops.
Stop Action Time	10 to 600 s	30 s	The time duration for the stop action sequence.
Additional Stopping Time	0 to 600 s	10 s	Additional time added to the engine stop sequence.
Load Transfer Delay	1 to 60 s	1 s	The time it takes to transfer the load to the mains or genset.

General

Parameter	Range	Default	Description
Power Save Mode Delay	5 to 1800 s	30 s	If the controller is not in use, the backlight turns off when the timer expires.
Screen Changeover Time	0 to 1800 s	3 s	The display page changes when the timer expires.
Deep Sleep Mode Delay	5 to 1800 s	10 s	If the controller is not in use, the controller goes into deep sleep mode when the timer expires.
Sounder Alarm Time	1 to 300 s	5 s	The alarm is activated when the alarm output is activated. The alarm stops when the timer expires.
Test Mode Timer	1 to 720 minutes	3 minutes	Engine run time during the test period.
Auto Exit Config Mode	10 to 1800 s	10 s	If the controller is not in use, the controller automatically exits the configuration mode when the timer expires.
Inlet shutoff Valve Pull Signal	0.0 to 2.0 s	0.1 s	The output for the pull signal for the inlet shutoff valve is active for this time duration.
Gen Breaker Pulse Timer	0.1 to 5.0 s	0.5 s	The time duration for the genset breaker pulse.
Mains Breaker Pulse Timer	0.1 to 5.0 s	0.5 s	The time duration for the mains breaker pulse.
Breaker Feedback Timer	1.0 to 10.0 s	2.0 s	The timer for breaker feedback.
Breaker Close Delay	0.1 to 30.0 s	2.0 s	Configure the time to charge the generator breaker spring before the breaker closes.

5.6.7 Generator

Alternator Configuration

Parameter	Range	Default	Description
Alternator Present	Enabled Not enabled	Not enabled	Not enabled: All generator parameters are not enabled. Enabled: All generator parameters are enabled.
Number of Poles	2, 4, 6, or 8	4	The pole number in the alternator.
Min Healthy Voltage	70 to 100 %	80 %	When the voltage has reached the set point, the genset starts to warm up.
Min Healthy Frequency	70 to 100 %	80 %	When the frequency has reached the set point, the genset starts to warm up.
Phase Reversal Detection	Enabled Not enabled	Not enabled	If this parameter is enabled, a phase reversal is detected if the phase sequence is not L1-L2-L3.
Phase Reversal Action	None Notification Warning Electrical Trip Shutdown	None	Configure the action for phase reversal detection.
Auto Generator Breaker Close In Mutual	Enabled Not enabled	Not enabled	If this parameter is enabled, the load is automatically transferred to the genset when the voltage and frequency are more than their

Parameter	Range	Default	Description
			minimum set points and the genset is running. This is only for manual mode.
Alternator Wave Detection	Enabled Not enabled	Not enabled	Use this function to analyse and verify the genset voltage pattern. The running hours counter and energy meters counter start when the controller has analysed (and verified) the pattern.
Gen PT Enable	Enabled Not enabled	Not enabled	If the application includes a genset power transformer (PT), enable this parameter.
Gen PT Primary Voltage	100 to 27000	100	Configure the PT primary value.
Gen PT Secondary Voltage	100 to 520	100	Configure the PT secondary value.

Nominal Values

Parameter	Range	Default	Description
Nominal AC System	1 Ph(L1-N) 3 Ph(L1-L2-L3-N) Split Ph(L1-N-L2) Split Ph(L1-N-L3) 2 Ph(L1-L2-N) 2 Ph(L1-L3-N) 3 Ph(L1-L2-L3)	3 Ph(L1-L2-L3-N)	Select the AC system for the generator.
Nominal Voltage Ph-N	46 to 15588 V	231 V	Cannot be configured. Based on Ph-Ph value.
Nominal Voltage Ph-Ph	80 to 27000 V	400 V	Configure the nominal voltage value.
Nominal Frequency	5.0 to 75.0 Hz	50.0 Hz	Configure the nominal frequency value.
Nominal Load Current	0 to 8000 A	350 A	Configure the nominal value for the load current.
Nominal 4th Current	0.0 to 8000.0 A	800.0 A	Configure the nominal value for the 4th current.
Nominal Speed	100 to 4000 RPM	1500 RPM	Configure the nominal speed value.
Nominal Power	1 to 20000 kW	200 kW	Configure the nominal power value.
Alternate Nominal AC System	1 Ph(L1-N) 3 Ph(L1-L2-L3-N) Split Ph(L1-N-L2) Split Ph(L1-N-L3) 2 Ph(L1-L2-N) 2 Ph(L1-L3-N) 3 Ph(L1-L2-L3)	3 Ph(L1-L2-L3-N)	Select the AC system for the alternator.
Alternate Nominal Voltage Ph-N	46 to 15588 V	231 V	Cannot be configured. Based on Ph-Ph value.
Alternator Nominal Voltage Ph-Ph	80 to 27000 V	400 V	Configure the nominal value for the alternator voltage.
Alternator Nominal Frequency	5.0 to 75.0 Hz	60.0 Hz	Configure the nominal value for the alternator frequency.
Alternator Nominal Load Current	0 to 8000 A	350 A	Configure the nominal value for the alternator load current.

Parameter	Range	Default	Description
Alternator Nominal 4th Current	0.0 to 8000.0 A	800.0 A	Configure the nominal value for the alternator 4th current.
Alternator Nominal Speed	100 to 4000 RPM	1800 RPM	Configure the nominal value for the alternator speed.
Alternator Nominal Power	10 to 20000 kW	200 kW	Configure the nominal value for the alternator power.

Voltage Monitoring

Parameter	Range	Default	Description
Under-voltage Shutdown	Enabled Not enabled	Not enabled	If this parameter is enabled, the controller shuts down the engine when the voltage is less than the configured set point for under-voltage.
Shutdown Threshold	10 to 99 %	80 %	When the voltage is less than this set point, the controller shuts down the engine.
Under-voltage Shutdown Delay	0.1 to 100.0 s	10.0 s	If the voltage is less than the set point for under-voltage shutdown (UV SHUTDOWN THRESH) when this timer expires, the controller shuts down the engine.
Under-voltage Warning	Enabled Not enabled	Not enabled	If this parameter is enabled, the display shows a warning when the voltage is less than the set point for the under-voltage warning.
Under-voltage Warning Threshold	11 to 100 %	90 %	When the voltage is less than the set point, the controller shows a warning message.
Under-voltage Warning Delay	0.1 to 100.0 s	10.0 s	If the voltage is less than the set point for under-voltage warning (UV WARNING THRESH) when this timer expires, the controller activates a warning alarm.
Over-voltage Shutdown	Enabled Not enabled	Not enabled	If this parameter is enabled, the controller shuts down the engine when the voltage is more than the configured set point for over-voltage.
Over-voltage Shutdown Threshold	101 to 200 %	120 %	When the voltage is more than the set point, the engine shuts down.
Over-voltage Shutdown Delay	0.1 to 100.0 s	10.0 s	If the voltage is more than the set point for over-voltage shutdown (OV SHUTDOWN THRESH) when this timer expires, the controller shuts down the engine.
Over-voltage Warning	Enabled Not enabled	Not enabled	If this parameter is enabled, the controller shows a warning message when the voltage is more than the over-voltage set point (OV WARNING THRESHOLD).
Over-voltage Warning Threshold	100 to 199 %	110 %	When the voltage is more than this set point, the engine shows a warning message.
Over-voltage Warning Delay	0.1 to 100.0 s	10.0 s	If the voltage is more than the set point for over-voltage warning (OV WARNING THRESH) when this timer expires, the controller activates a warning alarm.

Frequency Monitoring

Parameter	Range	Default	Description
Under-frequency Shutdown	Enabled Not enabled	Not enabled	If this parameter is enabled, the controller shuts down the engine when the frequency is less than the configured set point for under-frequency.
Shutdown Threshold	10 to 99 %	80 %	When the frequency is less than this set point, the controller shuts down the engine.
Under-frequency Shutdown Delay	0.1 to 100.0 s	10.0 s	If the frequency is less than the set point for under-frequency shutdown (UF SHUTDOWN THRESH) when this timer expires, the controller shuts down the engine.
Under-frequency Warning	Enabled Not enabled	Not enabled	If this parameter is enabled, the display shows a warning when the voltage is less than the set point for the under-voltage warning.
Under-frequency Warning Threshold	11 to 100 %	90 %	When the frequency is less than this set point, the controller shows a warning message.
Under-frequency Warning Delay	0.1 to 100.0 s	10.0 s	If the frequency is less than the set point for under-frequency warning (UF WARNING THRESH) when this timer expires, the controller activates a warning alarm.
Over-frequency Shutdown	Enabled Not enabled	Not enabled	If this parameter is enabled, the controller shuts down the engine when the frequency is more than the configured set point for over-frequency.
Shutdown Threshold	101 to 200 %	120 %	When the frequency is more than this set point, the engine shuts down.
Over-frequency Shutdown Delay	0.1 to 100.0 s	10.0 s	If the frequency is more than the set point for over-frequency shutdown (OF SHUTDOWN THRESH) when this timer expires, the controller shuts down the engine.
Over-frequency Warning	Enabled Not enabled	Not enabled	If this parameter is enabled, the controller shows a warning message when the frequency is more than the set point for the over-frequency warning.
Over-frequency Warning Threshold	100 to 199 %	110 %	When the frequency is more than this set point, the controller activates a warning alarm.
Over-frequency Warning Delay	0.1 to 100.0 s	10.0 s	If the frequency is more than the set point for over-frequency warning (OF WARNING THRESH) when this timer expires, the controller shuts down the engine.

Current Monitoring

Parameter	Range	Default	Description
Primary CT Ratio	0 to 8000	150	Primary CT ratio value
Secondary CT Ratio	1 5	5	Secondary CT ratio value
Over-current Action	None Notification Warning Electrical Trip Shutdown	None	Configure the action for over-current.

Parameter	Range	Default	Description
Over-current Threshold	10 to 200 %	120 %	The action for over-current is activated when the current is more than this set point.
Over-current Delay	1 to 600 s	1 s	When the delay timer expires, the action for over-current is activated if the current is more than over-current set point.
CT Location	On Alt Output Cable On Load Cable	On Load Cable	Configure the location of the CT. You can place the CT on the line from the genset or on the load cable.

Earth Leakage/Fan Current Monitoring

Parameter	Range	Default	Description
Current Monitoring	Earth Leakage Current Fan Current	Fan Current	Fan current: The current for the engine cooling fan is monitored. Earth leakage current: The earth leakage current is monitored.
CT Ratio	0 to 8000	0	The CT ratio when the fan current is monitored.
Fan Current Secondary CT Ratio	1 5	1	The ratio value for the secondary fan current.
High Current Action	None Notification Warning Electrical Trip Shutdown	None	The action that occurs when the current is more than the high current set point.
High Current Threshold	100 to 200 %	120 %	The action for high current is activated when the current is more than this set point.
Current Delay	0 to 180 s	0 s	When the delay timer expires, the action for high current is activated if the current is more than high current set point.
Low Current Action	None Notification Warning Electrical Trip Shutdown	None	The action that occurs when the current is less than the low current set point.
Low Current Threshold	0 to 100 %	20 %	The action for low current is activated when the current is less than this set point.

Load Monitoring

Parameter	Range	Default	Description
Overload Action	None Notification Warning Electrical Trip Shutdown	None	The action that occurs when the load is more than the overload set point.
Overload Threshold	100 to 200 %	110 %	The action for overload is activated when the load is more than this set point.
Overload Delay	1 to 3600 s	1 s	If the load is more than the set point for overload when the time expires, the action for overload is activated.

Parameter	Range	Default	Description
Unbalanced Load Action	None Warning Electrical Trip Shutdown Notification	None	The action that occurs when the load is more than the set point for unbalanced load.
Unbalanced Load Threshold	5 to 200 %	5 %	The action for unbalanced load is activated when the load is more than this set point.
Unbalanced Load Delay	1 to 600 s	1 s	If the load is more than the set point for unbalanced load when the time expires, the action for unbalanced load is activated.
Reverse Power Enable	Enabled Not enabled	Not enabled	Enable this parameter to activate reverse power monitoring.
Reverse Power Action	None Warning Electrical Trip Shutdown Notification	None	The action that occurs when the reverse power is more than the set point for reverse power.
Reverse Power Activation	Never Always From Monitoring On	Always	Configure when the controller starts to monitor the reverse power.
Reverse Power Threshold	-200 to -5 %	-5 %	The action for reverse power is activated when the reverse power is more than this set point.
Reverse Power Delay	1 to 100 s	5 s	If the reverse power is more than the set point for reverse power when the time expires, the reverse power is activated.
Low Load Enable	Enabled Not enabled	Not enabled	If this parameter is enabled, the configured action for low load is activated.
Low Load Action	None Warning Electrical Trip Shutdown Notification	None	The action that occurs when low load is detected. Low load is detected when the load is less than the set point for low load trip.
Low Load Trip	1 to 99 %	50 %	The set point for low load. When the load is less than this set point, the action for low load is activated.
Low Load Return	2 to 100 %	51 %	If the action for low load is a warning, the controller stops monitoring low load when the load is more than this set point.
Low Load Delay	1 to 3600 s	1 s	If the load is less than the set point for low load when the time expires, the low load action is activated.

5.6.8 Mains

Configuration

Parameter	Range	Default	Description
Mains Monitoring	Enabled Not enabled	Enabled	If this parameter is enabled, the controller monitors the mains voltage and frequency.
Mains AC System	1 Ph (L1-N) 3 Ph (L1-L2-L3-N) Split Ph (L1-N-L2)	3 Ph (L1-L2-L3-N)	Select the phase system for the mains.

Parameter	Range	Default	Description
	Split Ph (L1-N-L3) 2 Ph (L1-L2-N) 2 Ph (L1-L3-N) 3 Ph (L1-L2-L3)		
Phase Reversal Detection	Enabled Not enabled	Not enabled	If this parameter is enabled, a phase reversal is detected if the phase sequence is not L1-L2-L3.
Phase Reversal Action	None Notification	None	Configure the action for phase reversal detection.
Partial Healthy Detection	Enabled Not enabled	Not enabled	If this parameter is enabled, a mains failure is not detected if one or two of the phases fail. This is only for a 3-phase system.
Mains PT Enable	Enabled Not enabled	Not enabled	Enable this parameter, if the application includes a mains power transformer (PT).
Mains PT Primary Ratio	100 to 27000	100	Configure the PT primary value.
Mains PT Secondary Ratio	100 to 520	100	Configure the PT secondary value.
Mains Auto Load Transfer	Enabled Not enabled	Not enabled	
Nominal voltage	80 to 27000 V Ph -Ph	400 V Ph - Ph	Configure the nominal voltage value.
Nominal frequency	5 to 75 Hz	50 Hz	Configure the nominal frequency value.
Alternate nominal voltage	80 to 27000 V Ph -Ph	400 V Ph - Ph	Configure the alternative nominal voltage value.
Alternate nominal frequency	5 to 75 Hz	60 Hz	Configure the alternative nominal frequency value.

Voltage Monitoring

Parameter	Range	Default	Description
Under-voltage	Enabled Not enabled	Enabled	If this parameter is enabled, the controller detects a mains failure when the mains voltage is less than the under-voltage set point (UV trip).
Under-Voltage Trip	10 to 99 %	80 %	If the mains voltage is less than this set point, there is a mains failure.
Under-Voltage Return	11 to 100 %	90 %	The mains returns when the mains voltage is more than this set point.
Over-voltage	Enabled Not enabled	Enabled	If this parameter is enabled, the controller detects a mains failure when the mains voltage is more than the over-voltage set point (OV trip).
Over-Voltage Trip	101 to 200 %	120 %	If the mains voltage is more than this set point, there is a mains failure.
Over-Voltage Return	100 to 199 %	110 %	The mains returns when the mains voltage is less than this set point.
Voltage Monitoring Delay	0.1 to 100.0 s	10.0 s	If the voltage is more than the over-voltage set point when this timer expires, the action for over-voltage is activated.

Frequency Monitoring

Parameter	Range	Default	Description
Under-frequency	Enabled Not enabled	Enabled	If this parameter is enabled, the controller detects a mains failure when the mains frequency is less than the under-frequency set point (UF trip).
Under-frequency Trip	10 to 99 %	80 %	If the mains frequency is less than this set point, there is a mains failure.
Under-frequency Return	11 to 100 %	90 %	The mains returns when the mains frequency is more than this set point.
Over-frequency	Enabled Not enabled	Enabled	If this parameter is enabled, the controller detects a mains failure when the mains frequency is more than the over-frequency set point (OF trip).
Over-frequency Trip	101 to 200 %	120 %	If the mains frequency is more than this set point, there is a mains failure.
Over-frequency Return	100 to 199 %	110 %	The mains returns when the mains frequency is less than this set point.
Frequency Monitoring Delay	0 to 100 s	10 s	If the frequency is more than the over-frequency set point when this timer expires, the action for over-frequency is activated.

5.6.9 ECU Configuration

Engine Control Unit (ECU)

Parameter	Range	Default	Description
Engine Type	See SGC Mk II Engine communication for supported engines.	Conventional	Select the engine type.
Lube Oil Pressure	Enabled Not enabled	Not enabled	Read and monitor the lube oil pressure.
Coolant Temperature	Enabled Not enabled	Not enabled	Read and monitor the coolant temperature.
Engine Speed	Enabled Not enabled	Not enabled	Read and monitor the engine speed.
Running Hours	Enabled Not enabled	Not enabled	Read and monitor the engine running hours.
Battery Voltage	Enabled Not enabled	Not enabled	Read and monitor the battery voltage.
Speed	Enabled Not enabled	Not enabled	If this is enabled, the controller sends the requested engine speed to the ECU.
Start/Stop	Enabled Not enabled	Not enabled	If this parameter is enabled, the controller sends the start/stop commands to the ECU.
Preheat	Enabled Not enabled	Not enabled	If this parameter is enabled, the controller preheats the engine even if you have not configured an output for preheat.
Engine Gain	0.0 to 10.0	5.0	This is for Cummins engines.
Requested Droop	0.0 to 25 %	0.0	This is for Scania engines.
Speed Control	Standard J1939	Standard J1939	This is for Volvo engines.

Parameter	Range	Default	Description
	Volvo proprietary - Primary speed 50 Hz Volvo proprietary - Primary speed 60 Hz		
Live Link Enable	Enabled Not enabled	Not enabled	If this parameter is enabled, the controller establishes a live communication link to the ECU, allowing real-time data exchange for monitoring and remote display functionality.
Remote Display Config	Disable View Mode Control Mode	Disable	In <i>View mode</i> , the controller sends engine data to a remote display for monitoring only. In <i>Control mode</i> , the remote display can both view engine data and send control commands to the controller, which are forwarded to the ECU.

ECU Communication

Parameter	Range	Default	Description
Action	None Notification Warning Electrical Trip Shutdown	Warning	Configure the action for ECU communication failure.
Activation	Never From Engine Start From Monitoring On Always While Fuel Relay ON	While Fuel Relay ON	Configure when the controller monitors the ECU communication.
Activation Delay	1 to 60 s	1 s	If there is a communication failure when the delay timer expires, the action for ECU communication failure is activated.
SGC Source Address	0 to 253	3	Source address for the SGC.
ECU Source Address	0 to 253	0	Source address for the ECU.
Child ECU Source Address	-1 to 253	-1	Source address for the child ECU.

Configurable Source Address

Parameter	Range	Default	Description
TSC1 Source Address	-1 to 253	-1	Source address for the SGC.
CM1 Source Address	-1 to 253	-1	Source address for the ECU.
GC1 Source Address	-1 to 253	-1	Source address for the child ECU.

ECU Diagnostic Lamps

Parameter	Range	Default	Description
[Amber, Malfunction, Red, Protect] Lamp			
Action	None Notification Warning Electrical Trip Shutdown	Warning	Configure the action for the ECU diagnostics lamps.

Parameter	Range	Default	Description
Activation	Never From Engine Start From Monitoring On Always	Never	Configure when the controller monitors the diagnostics lamps.
Activation Delay	0 to 60 s	0 s	If there is a failure when the delay timer expires, the action for the ECU diagnostics lamps is activated.

Kohler ECU Reset

Parameter	Range	Default	Description
Kohler ECU Reset	Enabled Not enabled	Not enabled	Resets the Kohler ECU by removing power for the set time when enabled (engine must be stopped).
Kohler ECU Reset Time	0 to 300 s	5 s	

5.6.10 Maintenance

Maintenance

Parameter	Range	Default	Description
Alarm Action	None Notification Warning Electric Trip Shutdown	None	Configure the alarm action for maintenance.
Due At Engine Hours	10 to 65000 hours	250 hours	The maintenance timer is based on running hours.
Ash Load Enable	Enabled Not enabled	Not enabled	Enable this parameter to monitor the ash load.
Maintenance Alarm By Due Date	Enabled Not enabled	Not enabled	
Alarm Due Date	dd/mm/yyyy	-	An alarm occurs when it is the due date.

5.6.11 Reset counters

Counters for various values are included for genset and mains. These values can be adjusted, for instance if the controller is installed on an existing genset or a new circuit breaker has been installed. You can only configure the reset counters from the display.

Genset

Parameter	Range	Default	Description
Run time	0 to 60000	0	Offset adjustment of the total running hours counter.
No. of starts	0 to 60000	0	Offset adjustment of the number of starts.
No. of trips	0 to 60000	0	Offset adjustment of the number of trips.
Engine kWh	0 to 60000 kWh	0 kWh	Offset adjustment of the number of engine kWh.

Parameter	Range	Default	Description
Engine kVAh	0 to 60000 kVAh	0 kVAh	Offset adjustment of the number of engine kVAh.
Engine kVArh	0 to 60000 kVArh	0 kVArh	Offset adjustment of the number of engine kVArh.

Mains

Parameter	Range	Default	Description
Run time	0 to 60000	0	Offset adjustment of the total running hours counter.
Mains kWh	0 to 60000 kWh	0 kWh	Offset adjustment of the number of mains kWh.
Mains kVAh	0 to 60000 kVAh	0 kVAh	Offset adjustment of the number of mains kVAh.
Mains kVArh	0 to 60000 kVArh	0 kVArh	Offset adjustment of the number of mains kVArh.

5.6.12 Password ID

You can only configure the password ID on the display.

ID

Parameter	Input	Range	Description
ENG SR NO	#####	Numbers: 0 to 9 Letters: A to Z	The engine serial number.
PASSWORD 1	####	Numbers: 0 to 9	The password for level 1 access. The default is 0123.
PASSWORD 2	####	Numbers: 0 to 9	The password for level 2 access. The default is 1234.

6. Modes and applications

6.1 Running mode

The controller has two running modes:

- **AUTO:** The controller operates automatically, and the operator cannot initiate sequences manually.
- **Manual:** The operator has to initiate all sequences. You can do this with the buttons, Modbus commands, or digital inputs.

6.2 AUTO mode

In AUTO mode, you can select these functions:

- Island
- Engine drive
- Automatic mains failure (AMF)
- Site battery monitoring
- Cyclic
- Remote start/stop
- Auto exercise

To go to AUTO mode, push the *Mode selection* button until AUTO mode is shown on the display.

6.2.1 Island

The controller operates in island when:

- Mains monitoring and site battery monitoring are not enabled.
- Cyclic and auto exercise are not enabled.

In the smart connect software, go to `Mains > Configuration > Mains monitoring` and make sure that mains monitoring is not enabled. Go to `Module > Auto Exercise 1/ Auto Exercise 2` and make sure that auto exercise is not enabled.

The controller automatically starts the genset and closes the generator breaker at a digital start command. When the stop command is given, the generator breaker opens, and the genset is stopped after a cooling down period.

Use a digital input to activate and deactivate the start and stop commands. You cannot use the display buttons in AUTO mode.

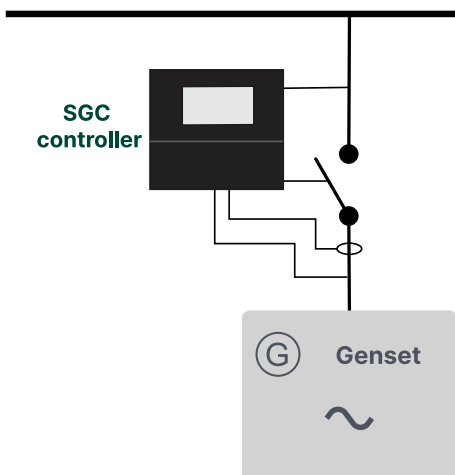

6.2.2 Engine drive

You can use the SGC to control one engine. The controller has all the necessary functions to control and protect an engine.

To use the controller to control an engine, go to `Generator > Alternator Configuration` in the smart connect software. Make sure that the *Alternator Present* parameter is set to *Not enabled*.

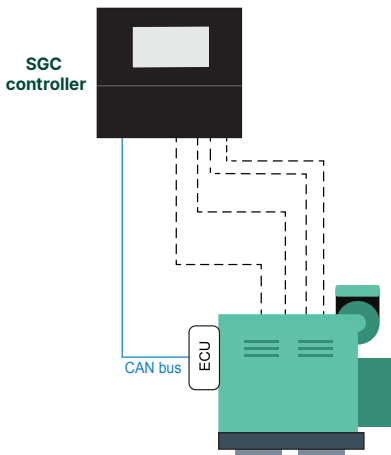

6.2.3 Automatic mains failure (AMF)

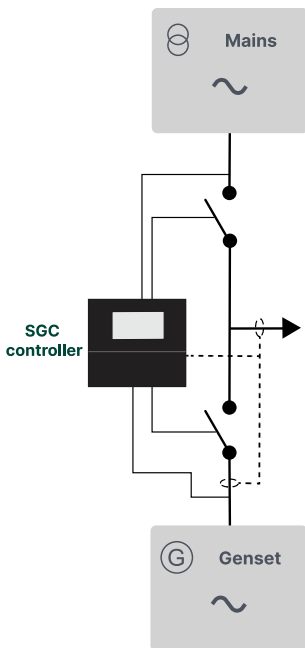

NOTE You can place the CT on the line from the genset or on the load side.

The AMF function is active when:

- Site monitoring, cyclic mode, and auto exercise are not enabled.
- Mains monitoring is enabled.

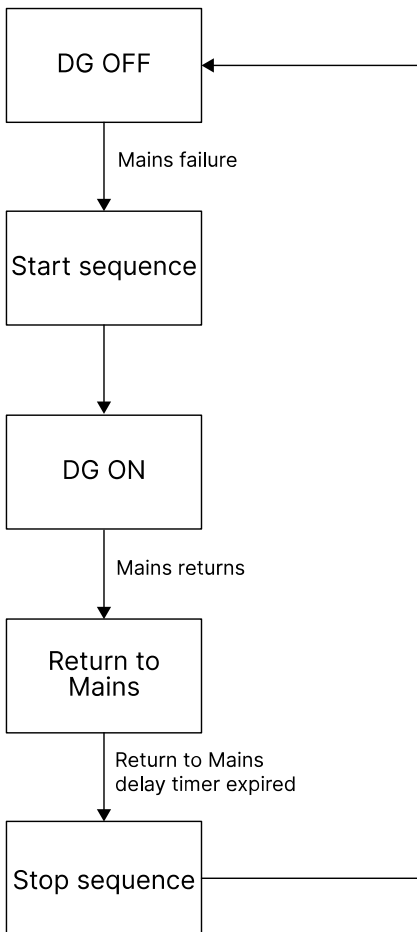

In the smart connect software, go to `Mains > Configuration > Mains monitoring` and make sure that mains monitoring is enabled. Go to `Module` in the smart connect software and make sure that auto exercise, cyclic mode, and site battery monitoring is not enabled.

If there is a mains failure, the SGC controller automatically starts the genset and switches to generator supply (see the flowchart above) after an adjustable delay time.

The genset starts as specified by the start sequence. When the genset loading voltage and frequency are more than their minimum set points, the *Warm-up delay* timer starts. At the end of the warm-up delay, the timer for the load transfer delay starts, and the genset breaker closes. When the mains returns, the controller synchronises the mains breaker to the busbar when the *Return to mains delay* timer has expired. The genset cools and then stops.

If the mains returns or a stop command or shutdown alarm occurs during the engine crank time, the controller will not send a start command. You must clear all the alarms manually to start the genset again.



More information

For parameters, see [Start/Sop](#) and [Alternator Configuration](#).

6.2.4 Site battery monitoring

Use this function to monitor the site battery and the shelter temperature. The SGC controls the power sources (mains or genset) to make sure that they battery voltage is more than the configured set point.

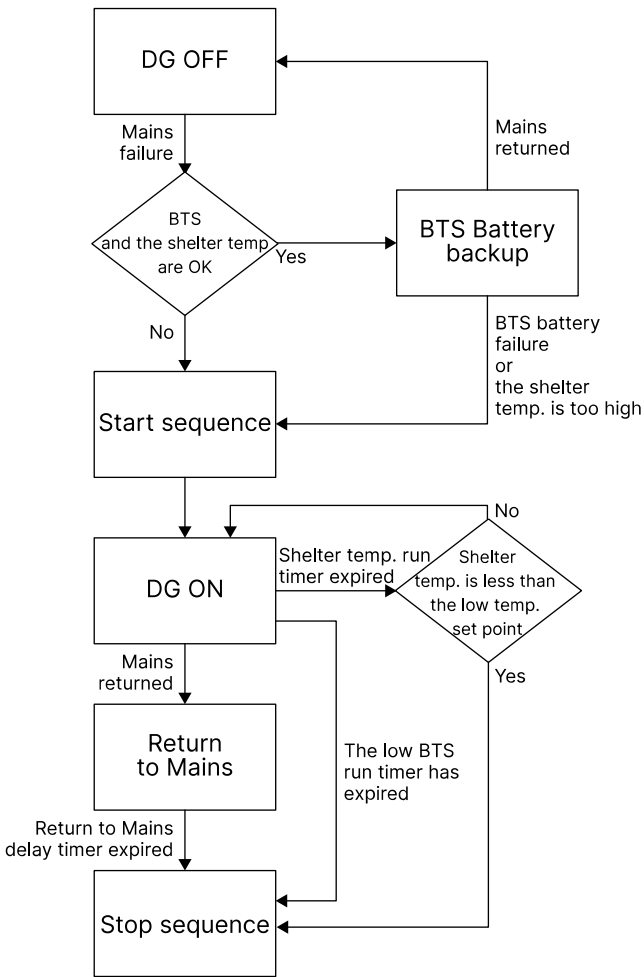

To enable site battery monitoring, go to `Module > Site Battery Monitoring`, and set *Battery Monitoring* to *Enabled*.

If there is a mains failure, the site battery supplies the load if:

- The battery voltage is more than the *Low Voltage Threshold* and
- The shelter temperature is less than the *High shelter temp* set point.

If the battery voltage is less than the configured set point for low voltage or the shelter temperature is more than the set point for high shelter temperature, the controller sends a start command to the genset. Once the genset loading voltage and frequency are more than their minimum set points, the *Warm-up delay* timer starts. At the end of the warm-up delay, the timer for the load transfer delay starts, and the genset breaker closes.

The genset operates until the *DG run duration* timer expires. You can configure a *DG run duration* timer for the site battery and the shelter temperature. If the genset starts as a response to the condition of the site battery voltage, the genset operates until the timer for the site battery expires. If the genset starts as a response to the condition of the shelter temperature, then the genset operates until the timer for the shelter temperature expires. If the shelter temperature is more than the *high shelter temp* set point when the timer expires, the *DG run duration* timer starts again. The genset continues to operate until the shelter temperature is less than the set point for high shelter temperature. .

When the mains returns or the *DG run duration* timer expires, the controller synchronises the mains breaker to the busbar when the *Return to mains delay* timer has expired. The genset cools and then stops.

Partially healthy

The site battery function also supports a *partially healthy* function for the mains. If the partially healthy function is enabled, then a mains failure is not detected when one or two of the phases fail. The mains continues to supply power through the available phase(s).

Mains failure occurs only when all three phases fail. When a mains failure occurs, the controller starts the genset if:

1. The site battery voltage is less than the set point for low voltage or
2. The shelter temperature is more than the set point for high shelter temperature or
3. Items 1 or 2 occurs when the mains is partially healthy.

Go to **Mains > Configuration** and set *Partial Healthy Detection* to *Enabled*.

NOTE It is recommended to keep *Mains monitoring* enabled when you monitor the site battery and to use the *Shelter temperature sensor* input only when *Site monitoring* is enabled.

To monitor the shelter temperature, go to *Analogue Inputs* and select one of the analogue inputs. For the *Use Input As* option, select *Shelter temperature sensor*.



More information

For parameters, see [Site Battery Monitoring](#), [Analogue Inputs](#), [Shelter Temperature Sensor](#), [Start/Stop](#) and [Alternator Configuration](#).

6.2.5 Cyclic mode

In this mode, the genset operates for an adjustable amount of time during a mains failure. You can adjust the genset operating hours and cooling down period. The maximum cycle is 12 hours.

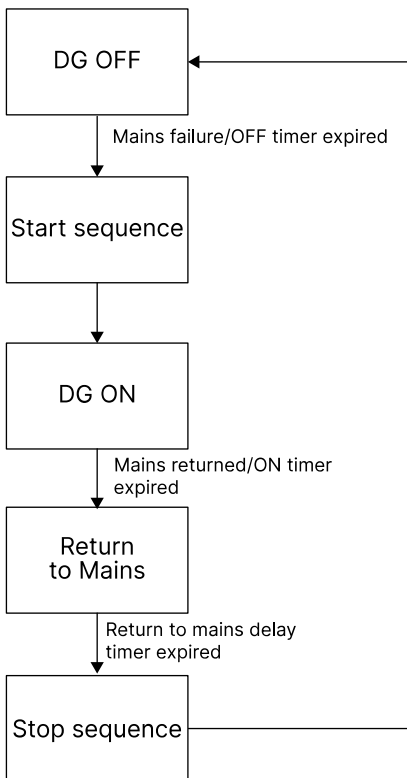

To activate cyclic mode, go to **Module > Cyclic Mode** and set *Cyclic Mode* to *Enabled*.

During normal operations, the mains supplies the load. If there is a mains failure, the controller automatically starts the genset and switches to generator supply (see the flowchart above). Once the genset loading voltage and frequency are more than their minimum set points, the *Warm-up delay* timer starts. When the *Warm-up delay* timer expires, the timer for the load transfer delay starts, and the genset breaker closes. When the mains returns, the controller synchronises the mains breaker to the busbar when the *Return to mains delay* timer has expired. The genset cools and then stops.

If there is still a mains failure after the genset has cooled down and stopped, the controller starts the genset again. At the end of the cycle, the genset cools down and then stops. This cycle continues until the mains returns. If the mains returns during a cycle, the controller synchronises the mains breaker to the busbar when the *Return to mains delay* timer has expired. The genset cools and then stops. The timer for the genset operating cycle is also reset.

You must clear all alarms before the controller can start the genset. Once you have cleared the alarms, the genset starts if there is still a mains failure.



More information

For parameters, see [Cyclic Mode](#), [Start/Stop](#) and [Alternator Configuration](#).

6.2.6 Remote start/stop

You can configure digital inputs as remote start/stop inputs (latched type input). You can start and stop the genset remotely by activating the configured remote start/stop inputs.

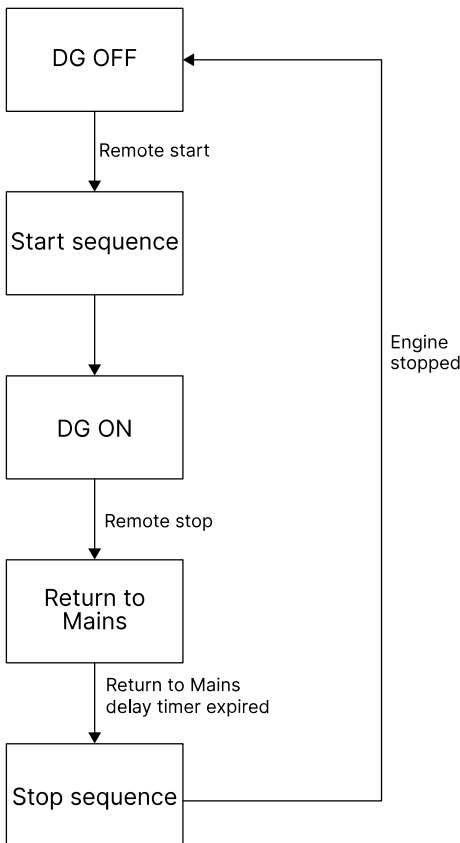

To configure the remote start/stop inputs, go to *Digital Inputs* in the smart connect software and select the source as *Remote Start/Stop*. You cannot use remote start/stop when mains monitoring is enabled. Go to *Mains > Configuration* and make sure the box next to *Mains Monitoring* is not selected.

When you activate the remote start input, the controller sends a start command to the genset. Once the genset loading voltage and frequency are more than their minimum set points, the *Warm-up delay* timer starts. At the end of the warm-up delay, the timer for the load transfer delay starts, and the genset breaker closes.

When you activate the remote stop input, the controller opens the genset breaker, and the genset cools and stops.



More information

For parameters, see [Start/Stop](#) and [Alternator Configuration](#).

6.2.7 Auto exercise

You can use auto exercise mode to schedule a maximum of two start/stop sequences for the genset. The sequences can occur daily, weekly, or monthly. The load transfer on the mains/genset is also configurable.

The exercise mode is activated when a scheduled sequence starts. The scheduled sequence only starts if there are no alarms. The sequence runs for the adjustable *DG ON duration* time. When the *DG ON duration* timer expires or when you push the *Stop* button, the engine cools down and then stops. The controller is no longer in exercise mode when the engine has stopped. If you have scheduled two sequences to start at the same time, a minute is added to the start time for the second sequence.

The genset does not start if a sequence is scheduled to start when the controller is in manual mode. If you change the running mode to AUTO mode during a scheduled sequence, the genset starts and operates for the remaining duration time.

If the controller is in AMF mode when a sequence is scheduled to start, the controller changes to exercise mode for the *DG ON duration* time. The controller returns to AMF mode once the *DG ON duration* has expired. If a mains failure occurs during a scheduled sequence (exercise mode), the genset continues to run for the *DG ON duration* time, and then returns to the AMF mode. Load is then transferred to the genset. When the mains returns, the genset cools down and stops.



More information

For parameters, see [Auto Exercise 1](#) and [Auto Exercise 2](#).

6.3 Manual mode

In manual mode, the operator must start all sequences. You can do this with the display buttons, Modbus commands, or digital inputs.

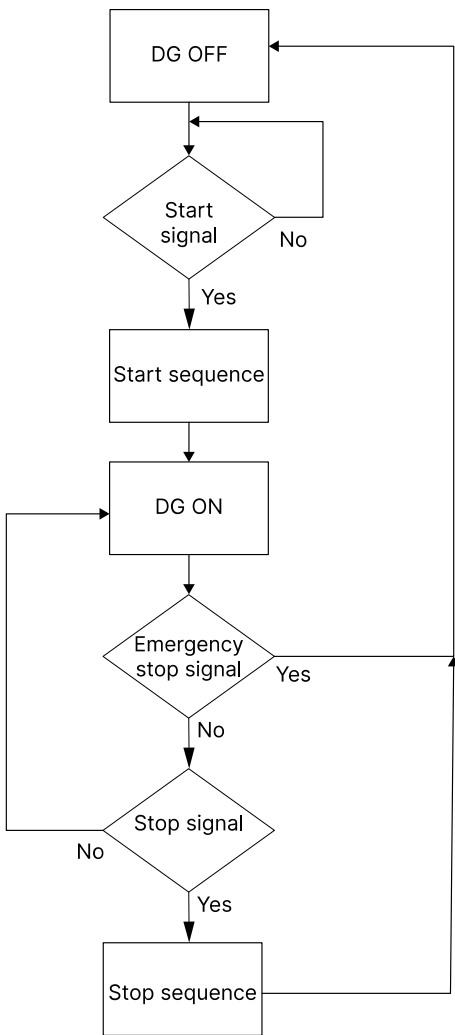



Commands in manual mode

Command	Description
Start	The start sequence is started and continues until the genset starts or the maximum number of starts attempts is reached. The controller regulates the voltage and frequency to make the genset breaker ready to close.
Stop	The stop sequence is started and continues until the genset stops. The genset is stopped with cooling down time.
Close the mains breaker	The controller closes the mains breaker if the generator breaker is open, or synchronises and closes the mains breaker if the generator breaker is closed.
Open the mains breaker	The controller opens the mains breaker.
Close the genset breaker	The controller closes the generator breaker if the mains breaker is open, or synchronises and closes the generator breaker if the mains breaker is closed.
Open the genset breaker	The controller ramps down and opens the generator breaker at the breaker open point if the mains breaker is closed. The controller opens the generator breaker instantly if the mains breaker is open or the controller is in island mode.
Acknowledge alarms	Push the acknowledge button to acknowledge an alarm in manual and AUTO mode.

6.4 Test mode

Push the *Mode selection*  button until TEST is shown on the display. You can also activate the test mode with a digital input.

In test mode, the genset breaker only closes if you push the *Genset breaker*  button. Once the genset starts in test mode, the test mode timer starts. After the *Stop/Config*  button is pressed or the timer has expired, the controller sends a stop command to the genset. The genset stops as specified by the stop sequence.



More information

See [Stop sequence](#) for an overview of what happens during the stop sequence.

6.5 Deep sleep mode

You can use the deep sleep function to extend the battery life. This function allows you to stop all standard functions on the controller and decrease the power consumption. The controller keeps the same status and alarms as before it went into deep sleep mode. Standard functions are activated when the controller is no longer in deep sleep mode.

In the smart connect software or on the controller, go to `Module > General > Deep Sleep Mode` to enable the deep sleep function. The controller goes into deep sleep mode after an adjustable time of inactivity. You can configure this timer in `Timers > General > Deep Sleep Mode Delay`. Push a button to exit deep sleep mode.



More information

For parameters, see [General \(Module\)](#) and [General \(Timers\)](#).

The controller does not go into deep sleep mode if:

- The controller is in AUTO mode.
- Mains monitoring is enabled and the mains breaker is configured as an output.
- Modbus communication is enabled.

7. General functions

7.1 Passwords











The controller is protected from set-up changes with a four digit password.

There are two password levels that can be configured on the controller. Parameter settings cannot be changed with a lower ranking password, but are shown on the display.

Level	Access	Factory setting	Comment
1	Full access (read and write)	0123	You can read and configure all parameters.
2	Limited access (read, and limited write)	1234	You can read all parameters, and configure a limited number of parameters.

Go to the configuration menu and push the *Stop*  button to only read all parameters.

Configure the password on the controller

1. Push and hold the *Stop/Config*  to go to the configuration menu.
2. Enter the password for level 1.
3. Use the *Up*  and *Down*  buttons to go to `ID > Password 1/Password 2`, and push the *Start*  button to select.
4. Use the *Up*  and *Down*  buttons to go to the password you want to change, and select it with the *Start*  button.
5. Use the *Up*  and *Down*  buttons to choose the first digit for the new password, and push the *Start*  button to confirm your selection.
6. Repeat steps 4 and 5 for the next three digits.
7. When you have configured all four digits, a *Password changed* message is shown on the display.

7.2 AC measurement systems

The AC system can be three-phase, two-phase, single-phase, or split phase.



CAUTION



Incorrect configuration is dangerous

Configure the correct AC configuration. If in doubt, contact the switchboard manufacturer for information.



More information

For parameters, see [Alternator configuration \(Generator\)](#) and [Configuration \(Mains\)](#).

7.3 Nominal settings

Configure the nominal and alternate nominal electrical values.



More information

For parameters, see [Nominal Values](#).

7.4 Breakers

7.4.1 Breaker types

There are 2 breaker type settings.

Pulse

This setting is for breakers that have 2 separate coils for opening and closing the breaker.

The controller uses these outputs:

- To close the circuit breaker, the *Close Gen breaker* output is activated. The output is active until the *Breaker Close Pulse* timer expires. You can configure a *Breaker Feedback* timer and a digital input as *Breaker Close Feedback*. If the controller does not receive feedback before the *Breaker feedback* timer expires, a *Close Failure* alarm is shown. If *Breaker Close Feedback* is not configured, then an alarm is not shown.
- To open the circuit breaker, the *Open Gen breaker* output is activated. The output is active until the *Breaker Open Pulse* timer expires. You can configure a *Breaker Feedback* timer and a digital input as *Breaker Open Feedback*. If the controller does not receive feedback before the *Breaker feedback* timer expires, an *Open Failure* alarm is shown. If *Breaker Open Feedback* is not configured, then an alarm is not shown.

Continuous

This setting is for breakers that have a single coil for opening and closing the breaker.

The controller uses these outputs:

- To close the circuit breaker, the *Close Gen Output* is activated. You can configure a *Breaker Feedback* timer and a digital input as *Breaker Close Feedback*. If the controller does not receive feedback before the *Breaker feedback* timer expires, a *Close Failure* alarm is shown. If *Breaker Close Feedback* is not configured, then an alarm is not shown.
- To open the circuit breaker, the *Open Gen Output* is activated. You can configure a *Breaker Feedback* timer and a digital input as *Breaker Open Feedback*. If the controller does not receive feedback before the *Breaker feedback* timer expires, an *Open Failure* alarm is shown. If *Breaker Open Feedback* is not configured, then an alarm is not shown.



More information

For parameters, see [Breaker Feedback Timer](#).

7.4.2 Breaker spring load timer

To avoid breaker close failures in situations where the breaker close command is given before the breaker spring has been loaded, the spring load timer can be adjusted. You can do this with the *Breaker Close Delay* timer.



More information

For parameters, see [Breaker Close Delay](#).

7.5 Load calculations

For automatic mains failure (AMF) applications, you can place the current transformer (CT) on the line from the genset or on the load cable. The load calculations are based on where the CT is placed.

If the location of the CT is on the *On Alt Output* cable, which means the CT is on the genset side, then the load calculations are based on the genset load. The calculations do not depend on the breaker output or feedback input.

If the CT is placed on the load cable, then the load calculations are based on these conditions:

- If you have configured breaker feedback for the genset breaker and the mains breaker, then the load calculations are based on the breaker feedback. For example, if the controller receives breaker feedback from the mains breaker, then the load calculations are based on the mains load.
- If you have not configured breaker feedback for the breakers, then the load calculations are based on the breaker output. This is only for a continuous breaker type setting.

- If you have not configured breaker feedbacks and the breaker type setting is a pulse, then the load calculations are based on the genset load.
- If you have not configured breaker outputs or breaker feedbacks, then the load calculations are based on the genset load.

7.6 Alarms

You can configure warning and notification alarms on the controller. For example, an alarm for low oil pressure or a warning when the fuel level is low.

An alarm is shown on the display when the measured value is outside the configured limits for that value. The alarm LED turns red and the sounder alarm activates (if configured). You can see the type of the alarm on the alarms page, and why it occurred on the engine status page.

To acknowledge an alarm, push the *Up*  and *Down*  buttons at the same time.

You can configure the time interval for when an alarm can activate. You can select alarms to activate from when the engine starts, from when monitoring is on, or always. The controller cannot send a start command if a warning, electrical trip, or shutdown alarm is unacknowledged.

Alarm types

No.	Alarm actions	Description
1	Shutdown	The genset stops immediately and no longer supplies the load. The genset ignores the cooling down time.
2	Electrical trip	The genset stops supplying the load and the cooling down time starts. The genset stops when the cooling down has finished. You must acknowledge the electrical trip alarm before the controller can send a start command.
3	Warning	The genset continues to operate when there is a warning. A warning tells the operator that something has happened during operation. You must acknowledge all warning alarms before you can start the genset.
4	Notification	The controller shows the message on the display. Genset operations are not affected.

Alarms and their causes

No.	Alarms	Cause	Actions
1	Low Oil Pressure (Sensor)	The measured oil pressure is less than the configured value.	Shutdown Warning
	Low Oil Pressure (Switch)	The switch has measured a low oil pressure.	Shutdown Warning Electrical Trip Notification
2	Low Fuel level (Sensor)	The measured fuel level is less than the configured value. This is only detected when the genset is in operation.	Shutdown Warning
	Low Fuel level (Switch)	The switch has measured a low fuel level.	Shutdown Warning Electrical Trip Notification

No.	Alarms	Cause	Actions
3	High Eng CLNT Temp (Sensor)	The measured engine coolant temperature is more than the configured value. This is only detected when the genset is in operation.	Shutdown Warning
	High Eng CLNT Temp (Switch)	The switch has measured a high engine coolant temperature.	Shutdown Warning Electrical Trip Notification
4	Low Eng CLNT Temp (Sensor)	The measured engine coolant temperature is less than the configured value.	Shutdown Warning
5	Low Water Level (Switch)	The measured radiator water level is less than the preset threshold.	Shutdown Warning Electrical Trip Notification
6	Over Speed	Genset speed is more than the configured overspeed value. The genset shuts down after overspeed delay.	Shutdown
7	Gross Over Speed	Genset speed is more than the configured value for gross overspeed. The genset shuts down immediately without delay.	Shutdown
8	Under Speed	The engine speed is less than the preset RPM.	Shutdown
9	L1 Phase Over Voltage	Genset (L1) phase voltage is more than the configured over-voltage value.	Shutdown Warning
10	L1 Phase Under Voltage	Genset (L1) phase voltage is less than the configured under-voltage value.	Shutdown Warning
11	L2 Phase Over Voltage	Genset (L2) phase voltage is more than the configured over-voltage value.	Shutdown Warning
12	L2 Phase Under Voltage	Genset (L2) phase voltage is less than the configured under-voltage value.	Shutdown Warning
13	L3 Phase Over Voltage	Genset (L3) phase voltage is more than the configured over-voltage value.	Shutdown Warning
14	L3 Phase Under Voltage	Genset (L3) phase voltage is less than the configured under-voltage value.	Shutdown Warning
15	Over Frequency	Genset output frequency is more than the configured value.	Shutdown Warning
16	Under Frequency	Genset output frequency is less than the configured value.	Shutdown Warning
17	Emergency Stop	Emergency stop is activated. Or The emergency stop is configured as a digital input, and the input has triggered for longer than the configured time.	Shutdown
18	Charge Fail	The charge alternator voltage is less than the configured value.	Shutdown Warning Electrical Trip Notification
19	Battery Over Voltage	The battery voltage is more than the configured value.	Shutdown Warning Electrical Trip Notification
20	Battery Under Voltage	The battery voltage is less than the preset threshold.	Shutdown Warning

No.	Alarms	Cause	Actions
			Electrical Trip Notification
21	Over Current	Genset current is more than the preset threshold.	Shutdown Warning Electrical Trip Notification
22	Maintenance Due	The timer for engine running hours has expired. An alarm occurs when the running hours or days expires.	Notification Warning
23	Over Load	The measured kW load rating is more than the configured value.	Shutdown Warning Electrical Trip Notification
24	Auxiliary input/User defined name	The auxiliary input has triggered for longer than the configured time.	Shutdown Warning Electrical Trip Notification
25	Fail To Stop	The genset is operating after the controller has sent a stop command.	Shutdown
26	Fuel Theft	The fuel consumption is more than the configured limit.	Warning
27	Unbalanced Load	The load on a phase is more than or less than other phases by a configured value.	Shutdown Warning Electrical Trip Notification
28	No Speed Signal	There is no signal from the engine speed.	Shutdown
29	Fail To Start	The genset has not started after the configured number of start attempts.	Shutdown
30	Engine Temp/ Ckt Open (terminal 24)	The temperature sensor on terminal 24 is not detected (circuit open).	Shutdown Warning Electrical Trip Notification
31	Fuel Level Ckt Open	The fuel level sensor is not detected (circuit open).	Shutdown Warning Electrical Trip Notification
32	DG Phase Reversal	Alternator phase sequence (L1-L2-L3) is not correct.	Shutdown Warning Electrical Trip Notification
33	Mains Phase Reversal	Error during mains operation.	Notification
34	LOP/Ckt Open (terminal 26)	The oil pressure sensor on terminal 26 is not detected (circuit open).	Shutdown Warning Electrical Trip Notification
35	V-Belt Broken Switch	Failure of the V-belt. The belt drives the charging alternator.	Shutdown Warning Electrical Trip Notification
36	High Oil Pressure (Sensor)	The measured oil pressure is more than the configured value.	Warning
	High Oil Pressure (Switch)	The switch has measured a high oil pressure.	Warning

No.	Alarms	Cause	Actions
37	LOP/Ckt Open (terminal 23)	The oil pressure sensor on terminal 23 is not detected (circuit open).	Warning
38	LOP/ Shrt to Bat (terminal 23)	The oil pressure sensor on terminal 23 is not detected (short circuit).	Warning
39	AFT Activation Timeout	If the fuel level is less than the set point for automatic fuel transfer (AFT), the controller activates the AFT alarm and deactivates the AFT output.	Notification
40	Communication Failure	There is an ECU communication failure.	Shutdown Warning Electrical Trip Notification
41	Protect Lamp ON	The protect lamp on the ECU is active. A failure has occurred.	Shutdown Warning Electrical Trip Notification
42	Amber Lamp ON	The amber lamp on the ECU is active. A failure has occurred.	Shutdown Warning Electrical Trip Notification
43	Red Lamp ON	The red lamp on the ECU is active. A failure has occurred.	Shutdown Warning Electrical Trip Notification
44	MIL Lamp ON	The malfunction (MIL) lamp on the ECU is active. A failure has occurred.	Shutdown Warning Electrical Trip Notification
45	Eng Preheat Failed	The engine temperature is less than the configured value after the engine heater time has expired.	Warning
46	Ash Load 100 %	The amount of ash in the particular filter is 100%. The percentage is of nominal value.	Notification Warning
47	Low Load	The load is less than the configured set point after the delay timer has expired.	Shutdown Warning Electrical Trip Notification
48	Fail To Close Gen Output	Breaker close failure. Unable to close the genset breaker.	Shutdown Warning Electrical Trip Notification
49	Fail To Close Mains Output	Breaker close failure. Unable to close the mains breaker.	Shutdown Warning Electrical Trip Notification
50	Fail To Open Gen Output	Breaker close failure. Unable to open the genset breaker.	Shutdown Warning Electrical Trip Notification
51	Fail To Open Mains Output	Breaker close failure. Unable to open the mains breaker.	Shutdown Warning Electrical Trip Notification

No.	Alarms	Cause	Actions
52	Gen PH-PH Overvolt	Over-voltage measured for the phase-to-phase generator voltage. This is only for three-phase, 3 wires applications.	Shutdown Warning
53	Gen PH-PH Undervolt	Under-voltage measured for the phase-to-phase generator voltage. This is only for three-phase, 3 wires applications.	Shutdown Warning
54	Reverse Power Detected	Alarm is based on the active power (all phases), to the source, as measured by the controller.	Shutdown Warning Electrical Trip Notification
55	Custom sensor AI 1 to AI 7 Ckt fault	Custom sensor in Analogue input is not detected (Open circuit)	Shutdown Warning Electrical Trip Notification
56	Custom sensor AI 1 to AI 7 Sensor	Custom sensor value is above or below the thresholds	Shutdown Warning
57	Custom Logic Alarm	The Custom Logic alarm input has triggered for longer than the configured time.	Shutdown Warning Electrical Trip Notification
58	High Earth Leak Current	The High Earth leakage current has been detected for longer than the configured time.	Shutdown Warning Electrical Trip Notification
59	Battery Charger Fail	The battery charger Fail input has triggered for longer than the configured time.	Shutdown Warning Electrical Trip Notification
60	Smoke Fire	The Smoke Fire input has triggered for longer than the configured time.	Shutdown Warning Electrical Trip Notification
61	High Shelter Temp	The High shelter Temp input has triggered for longer than the configured time.	Notification
62	Panel Lock	The panel lock input has triggered for longer than the configured time.	Notification
63	Extrnl Auto Panel Lock	The External auto panel lock input has triggered for longer than the configured time.	Notification
64	Generator OFF Load	The Gen load inhibit input has triggered for longer than the configured time.	Notification
65	Mains OFF Load	The Mains load inhibit input has triggered for longer than the configured time.	Notification
66	Loading Vtg Not Reached	Loading Voltage is not reached	Shutdown
67	Loading Frq Not Reached	Loading Frequency is not reached	Shutdown
68	FAN High Current	Fan High current is detected for longer than the configured time	Shutdown Warning Electrical Trip Notification
69	FAN Low Current	Fan low current is detected for longer than the configured time.	Shutdown Warning Electrical Trip

No.	Alarms	Cause	Actions
			Notification
70	Invalid GEN run	Invalid Gen Run is detected.	Notification
71	Gen Breaker Ext Close	The Gen Breaker Ext close input has triggered for longer than the configured time.	Shutdown Warning Electrical Trip Notification
72	Gen Breaker Ext Open	The Gen Breaker Ext open input has triggered for longer than the configured time.	Shutdown Warning Electrical Trip Notification
73	Mains Breaker Ext Close	The Mains Breaker Ext close input has triggered for longer than the configured time.	Shutdown Warning Electrical Trip Notification
74	Mains Breaker Ext Open	The Mains Breaker Ext open input has triggered for longer than the configured time.	Shutdown Warning Electrical Trip Notification
75	Urea dosing malfunction	Urea dosing malfunction alarm on the ECU is active. A failure has occurred.	Warning
76	Critical emission failure	Critical dosing malfunction alarm on the ECU is active. A failure has occurred.	Warning
77	Incorrect urea detected	Incorrect urea detected alarm on the ECU is active. A failure has occurred.	Warning
78	Impeded EGR valve	Impeded EGR valve alarm on the ECU is active. A failure has occurred.	Warning
79	Urea level low	Urea level low alarm on the ECU is active. A failure has occurred.	Warning
80	Inducement buzzer	Inducement buzzer alarm on the ECU is active. A failure has occurred.	Warning
81	Common alarm	Common alarm on the ECU is active. A failure has occurred.	Warning
82	Engine Shutdown due to EGR Fault	The engine shutdown alarm due to an EGR fault on the ECU is active. A failure has occurred.	Warning
83	Engine Overspeed	The engine overspeed alarm on the ECU is active. A failure has occurred.	Warning
84	Engine Over Temperature (Pre-Waiting)	The engine over temperature alarm on the ECU is active. A failure has occurred.	Warning Notification
85	Engine Oil Pressure Low	The engine oil pressure low alarm on the ECU is active. A failure has occurred.	Warning
86	Water in Fuel	The water in fuel alarm on the ECU is active. A failure has occurred.	Warning
87	Engine Oil Temperature High	The engine oil temperature high alarm on the ECU is active. A failure has occurred.	Warning
88	Clogged Fuel Filter Status	The clogged fuel filter status alarm on the ECU is active. A failure has occurred.	Warning
89	Clogged Fuel Pre-Filter Status	The clogged fuel pre-filter status alarm on the ECU is active. A failure has occurred.	Warning

No.	Alarms	Cause	Actions
90	Clogged Air Filter Status	The clogged air filter status alarm on the ECU is active. A failure has occurred.	Warning
91	DEF Technical Failure	The DEF technical failure alarm on the ECU is active. A failure has occurred.	Warning
92	DEF Quality	The DEF quality alarm on the ECU is active. A failure has occurred.	Warning
93	DEF Level	The DEF level alarm on the ECU is active. A failure has occurred.	Warning
94	Low Idle Increase Desired	The low idle increase desired alarm on the ECU is active. A failure has occurred.	Warning
95	Diesel filter differential alarm	The diesel filter differential alarm on the ECU is active. A failure has occurred.	Warning
96	Oil filter differential alarm	The oil filter differential alarm on the ECU is active. A failure has occurred.	Warning
97	Air filter differential alarm	The air filter differential alarm on the ECU is active. A failure has occurred.	Warning
98	Fuel leak	The fuel leak alarm on the ECU is active. A failure has occurred.	Warning
99	Low temperature water level low	The low temperature water level low alarm on the ECU is active. A failure has occurred.	Warning
100	High temperature water level low	The high temperature water level low alarm on the ECU is active. A failure has occurred.	Warning
101	Horn alarm	The horn alarm on the ECU is active. A failure has occurred.	Warning
102	Light alarm	The light alarm on the ECU is active. A failure has occurred.	Warning
103	Oil Level state	The oil level state alarm on the ECU is active. A failure has occurred.	Warning
104	Fail to Open Mains continuous alarm	Breaker open failure. Unable to open the mains breaker.	Warning
105	Fail to Latch Mains alarm	Breaker close failure. Unable to close the mains breaker.	Warning
106	Fail to Open Gen continuous alarm	Breaker open failure. Unable to open the genset breaker.	Warning
107	Fail to Close Gen alarm	Breaker close failure. Unable to close the genset breaker.	Warning
108	RDC Comm Fail	There is an RDC communication failure.	Warning
109	ACU communication failure	There is an ACU ECU communication failure.	Shutdown Warning Electrical Trip Notification
110	OI severity shutdown	OI severity shutdown alarm on the ECU is active. A failure has occurred. See the ECU specific documentation for more information.	Shutdown
111	EGR Fault Warning *	EGR fault is detected. Check EGR ECU.	Warning
112	EGR Fault Shutdown *	EGR fault is detected and has crossed the shutdown delay. Check EGR ECU.	Shutdown

NOTE * Alarm is generated only when the EGR digital input is configured and the fuel relay is on.



More information

See [SGC Mk II Engine communication](#) for more information.

7.7 M-Logic

The main purpose of M-Logic is to give the operator and designer more flexibility. M-Logic is used to execute different commands at predefined conditions. M-Logic is not a PLC but substitutes one, if only very simple commands are needed.

M-Logic is a simple tool based on logic events. One or more input conditions are defined, and at the activation of those inputs, the defined output will occur. You can select different inputs, for example, digital inputs, alarm conditions and running conditions. A variety of the outputs can also be selected, such as relay outputs. You can configure M-Logic in the smart connect software.

7.7.1 Logical rungs

Use the logical rungs in the Smart Connect Mk II software to combine multiple digital events using logical operators. The output of the logic can be used to activate a function or an alarm.

How to configure logical rungs

1. Select *M-Logic* from the left toolbar and select the *Logical Rungs* tab.
2. Select the required events from the drop-down lists for *Event A*, *Event B*, and *Event C*. Each event represents a digital signal, for example a digital output status.
3. To invert the logical state of an event, enable *NOT* for the required input.
4. Select the logical operators (*AND* or *OR*) to define how the events are combined.
5. Enter a value for *ON delay* to delay activation of the output when the logic condition becomes true.
6. Enter a value for *OFF delay* to delay deactivation of the output when the logic condition becomes false.
7. Select the *Output* from the drop-down list.
8. To invert the logic result, set *Invert* to *Enabled*.
9. To enable the logic, set *Enable logic* to *Enabled*.

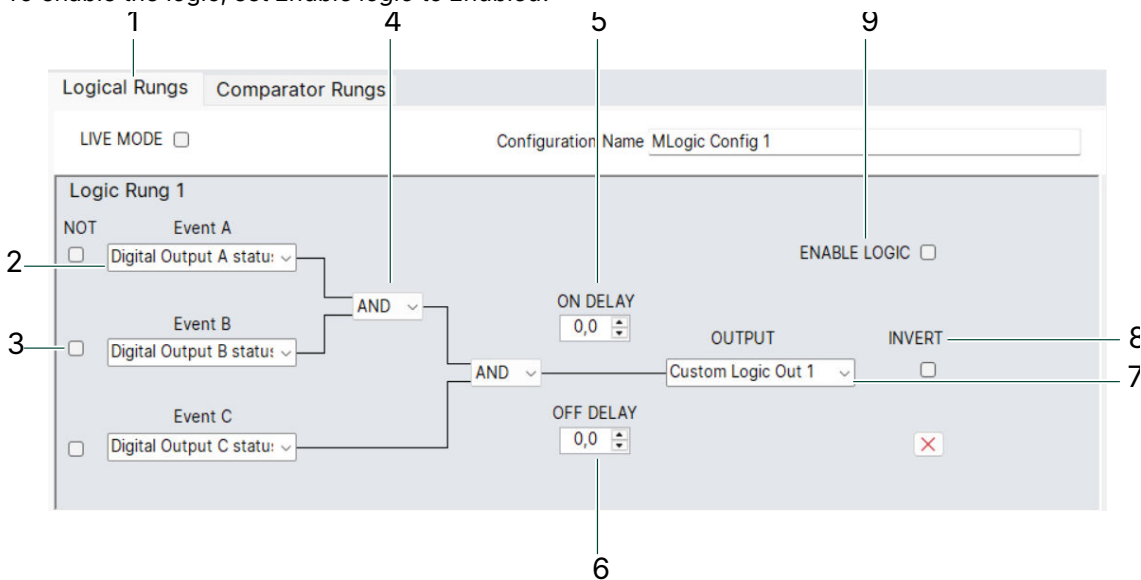

7.7.2 Comparator rungs

Use the comparator rungs in the Smart Connect Mk II software to compare a configurable input to a constant value. The output of the comparison can be used to activate a function or an alarm.

How to configure the comparator rungs

1. Select *M-Logic* from the left toolbar and click on the *Comparator Rungs* tab.

2. Select the input from the drop-down list. The input is an analogue value, for example, the BTS battery voltage.
3. Use the *Operator* to select if the input is greater than, less than, or equal to the constant value.
4. Enter the constant value.
5. Select the *Output* from the drop-down list.
6. To invert the output, set *Invert* to *Enabled*.
7. Enter a value for the hysteresis. The output is deactivated when the input value is less than the constant value minus the hysteresis.
8. To enable the logic, set *Enable logic* to *Enabled*.

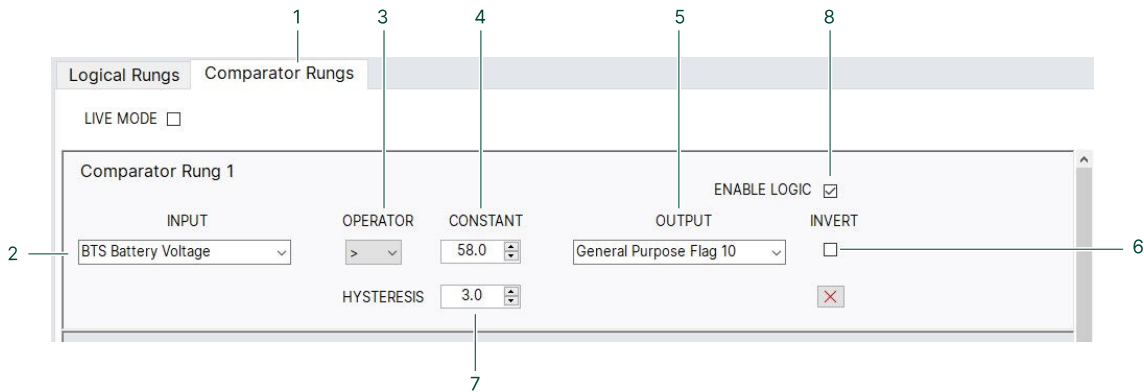

7.7.3 EGR related M-logic

The table below lists the EGR related M-Logic inputs and outputs used for monitoring and control when EGR monitoring is enabled.

Type	Name	Description
Input	EGR Fault timer	Indicates the duration of an active EGR fault.
Input	EGR Heal timer	Indicates the duration of the healthy state after a fault has cleared.
Input	EGR fault number	Indicates the fault number associated with the active EGR condition.
Input	EGR Fault Present	Indicates whether an EGR Fault Warning is active.
Input	EGR Fault Shutdown	Indicates whether an EGR Fault Shutdown is active.
Output	EGR ECU	Indicates the interpreted EGR ECU status based on input signals
Output	Command EGR Fault Shutdown	Triggers the EGR Fault Shutdown alarm.
Output	Command EGR Reset Timers	Resets the fault timer and heal timer to 0.

NOTE EGR events and commands can be monitored using the *Live supervision* feature.



More information

For more information, see [External EGR monitoring](#).

7.8 Language

7.8.1 Language pack

The controller can show several languages. The default master language is English, which cannot be changed. Different languages for the controller display can be configured with the smart connect software

Tools > Language Pack

Parameter	Range	Default	Description
Select Active Language	English	English	Select the language shown on the controller.

You can also upload a language pack to the smart connect software and write this to the controller. Click on the *Add* button to add a new language pack. To remove a language pack, click on the *Remove/Load Default* button.

Configure the controller language

1. Select *Language Pack* from the tools menu on the left.
2. Select the language from the *Select Active Language* drop-down list.
3. Click the *Write Language Pack to device* icon.

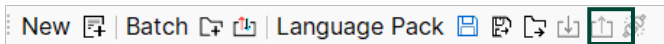

Language Pack menu

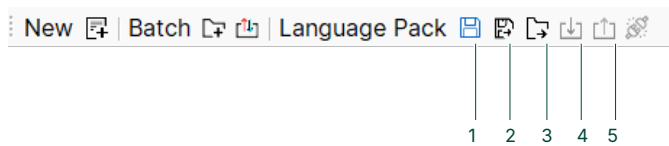

1. Save a language pack file.
2. Open a new language pack file.
3. Write the language pack to the SGC controller.
4. Read the language pack from the controller.

You can also use the drop-down menu for the language pack found in the top toolbar. You must have selected the **Language Pack** tab from the **Tools** menu to see this drop-down menu.

7.8.2 Smart connect language

The smart connect software can show several languages. The default master language is English, which cannot be changed. Different languages for the software can be configured.

Settings > Smart Connect Language

Parameter	Range	Default	Description
Select Active Language	English	English	Select the language shown on the controller and software.

You can also upload a language pack to the smart connect software. Click on the *Add* button to add a new language pack. To remove a language pack, click on the *Remove/Load Default* button.

8. Engine functions

8.1 Engine sequences

The engine start and stop sequences are started automatically if AUTO mode is selected. In manual mode, the operator has to initiate the sequences.

8.2 Engine start functions

8.2.1 Start sequence

The following drawing shows the start sequence of the genset.

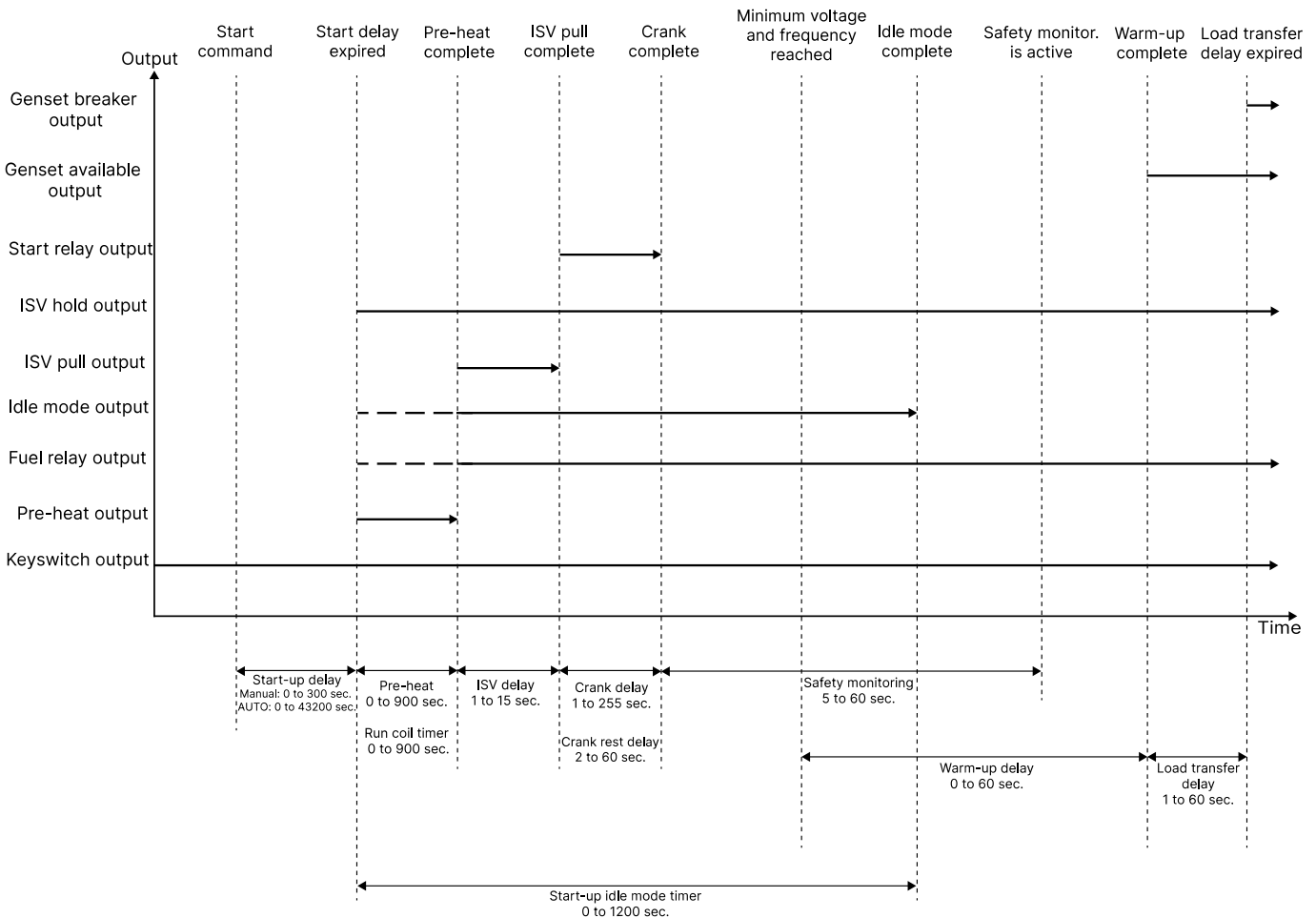

Configure the run coil timer to activate the fuel relay output and the idle mode output before pre-heat is completed.



More information

For parameters, see [Cranking](#), [General](#), [Preheat](#) and [Speed Monitoring](#).

Start sequence flowchart

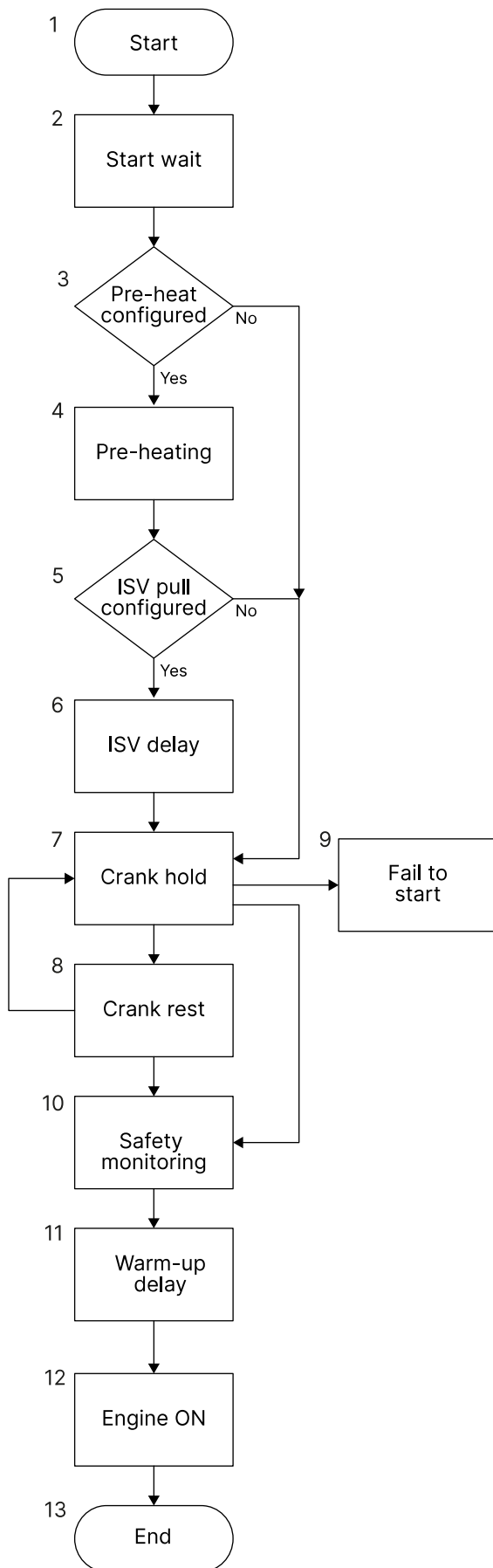

1. The controller sends a start signal to the genset.
2. The *Start Delay* timer is activated.
3. When the *Start Delay* timer expires, the pre-heating function is activated if this is configured. If pre-heating is not configured, go to step 7 (crank hold).
4. Pre-heating is active for the duration of the pre-heat timer (Preheat Timer).
5. When the pre-heat timer expires, the controller activates the Inlet Shutoff Valve (ISV) Pull function if this is configured. If this function is not configured, go to step 7 (crank hold).
6. The ISV pull function is active for the duration of the ISV delay timer.
7. The controller activates the start relay output and attempts to crank the engine. The controller starts the crank hold timer.
8. If the crank is not disconnected when the crank hold timer expires, the controller starts the crank rest timer. The rest time is the time between two cranking attempts. When the crank rest timer expires, the controller attempts to crank the engine again (step 7).
9. If the engine does not start after the maximum cranking attempts, the controller shows the *Fail to start* alarm.
10. The *Safety Monitoring Delay* timer starts after the crank disconnects. The engine safety parameters are not monitored for this duration.
11. The warm-up delay timer starts when the *Safety Monitoring Delay* timer expires.
12. The genset starts when the *Warm-up delay* timer expires.

8.3 Engine stop functions

8.3.1 Stop sequence

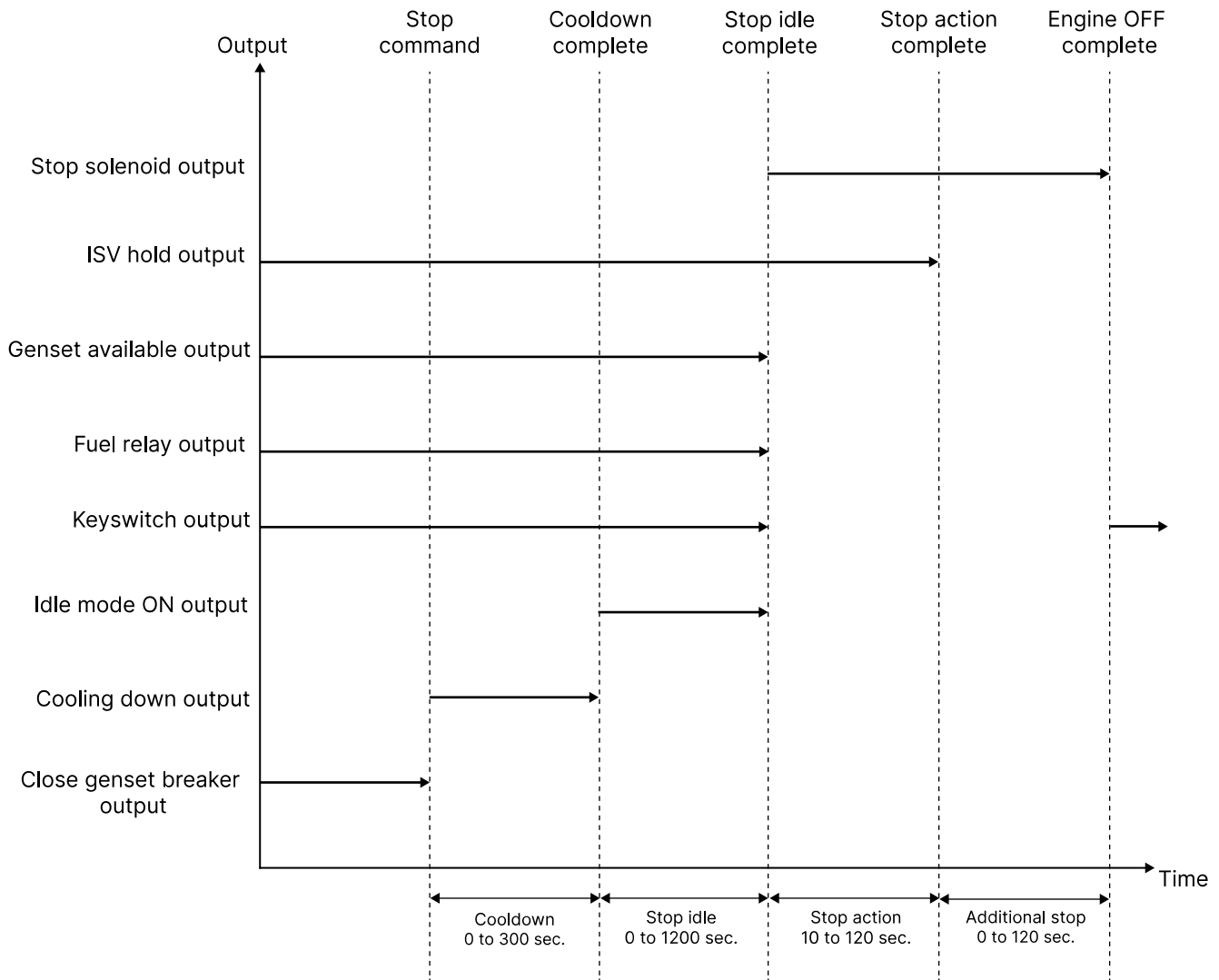

The stop sequence is activated if a stop command is given. The stop sequence includes the cooling down time if the stop is a normal or controlled stop.



More information

For parameters, see [Start/Stop](#) and [Speed Monitoring](#).

8.3.2 Stop sequence flowchart

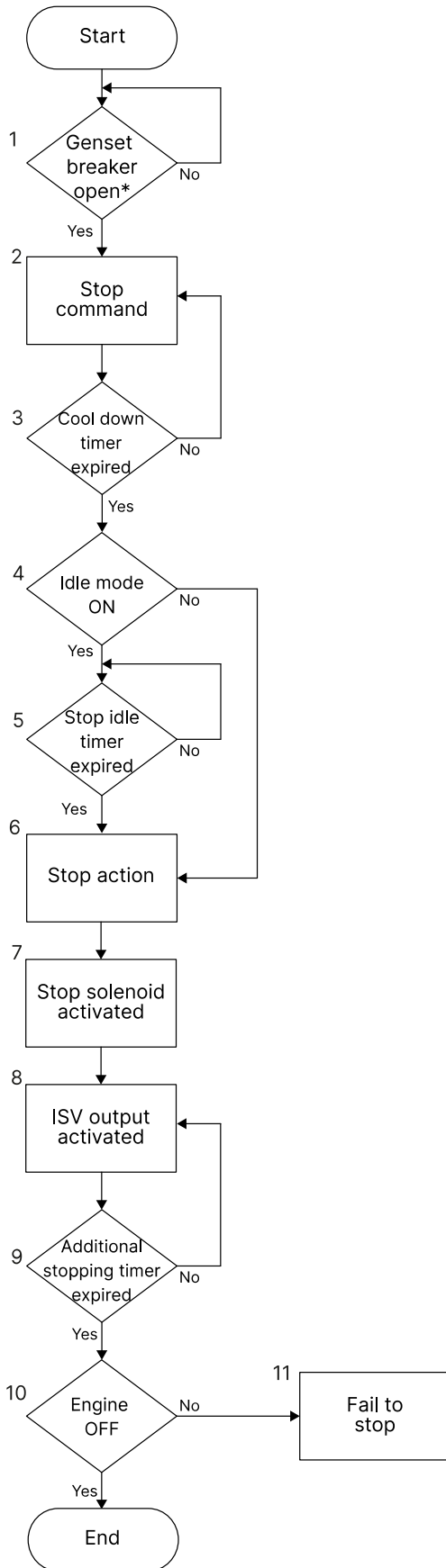

NOTE * If a breaker is configured.

1. The genset breaker opens if there is a breaker in the application.
2. A stop command is given. You can activate the command with a digital input or Modbus. You can only use the display buttons in manual mode.
3. The *Cool down* timer is activated.
4. If the idle mode output is configured, it is activated when the *Cool down* timer expires. If idle mode is not configured, then go to step 7 (stop action).
5. The *Stop Idle* timer is activated.
6. When the *Stop Idle* timer is expired, the *Stop Action* timer is activated. The fuel relay output, keyswitch output, genset available output, and Idle mode ON output are all deactivated before the *Stop action* timer is activated.
7. The *Stop solenoid* output is activated.
8. The output for the Inlet Shutoff Valve (ISV) hold is activated. The output is deactivated when the *Stop Action* timer is expired.
9. When the additional stopping timer is expired, the *Stop Solenoid* output is deactivated, and the engine stops.
10. The engine is stopped.
11. If the engine does not stop when the *Additional Stopping* timer has expired, the controller shows the *Failure to Stop* alarm.

8.4 Idle mode

The purpose of the idle mode function is to allow the engine to operate at idle speed before ramping up to rated speed.

You can activate idle mode using a digital input or a timer. If you have configured an input and a timer for idle mode, then the timer is overruled. The output assigned to idle mode can be continuous or pulse.

Configuration of digital input and output

1. Go to *Digital Inputs* and select one of the digital input tabs.
2. Select *Idle Mode Enable* as the source.
3. Select the polarity as *Close To Activate* or *Open To Activate*.
4. Go to *Digital Outputs* and select the source:
 - a. To use a continuous signal, select *Idle Mode On* as the source.
 - b. To use a pulse signal, select *Idle Mode On Pulse* and *Idle Mode Off Pulse* as two separate sources.
5. If you have selected a pulse signal as an output, you must configure the timer for the pulse.
 - a. Go to *Engine* and select *Speed Monitoring*.
 - b. Configure the *Idle Mode Pulse Time*.
6. In the *Speed monitoring* tab, configure the *Idle to Rated Delay Time*.

Idle mode is activated when the engine is started and the digital input is activate (open or close to activate). The under-voltage, under-frequency, and under-speed protections are not active during idle running.

The *Idle to Rated Delay* timer starts when the idle mode input is deactivated. The genset starts to ramp up, and when the timer expires, the genset operates at nominal speed. The under-voltage, under-frequency, and under-speed protections are also activated.

Configuration of timers

You can only activate idle mode with timers, when the *Idle Mode Enable* is deactivated.

1. Go to *Digital Inputs* and make sure that *Idle Mode Enable* is not selected as the source for a digital input.
2. Go to *Digital Outputs* and select the source:
 - a. To use a continuous signal, select *Low Idle Mode* as the source.
 - b. To use a pulse signal, select *Idle Mode On Pulse* and *Idle Mode OFF Pulse* as two separate sources.
3. If you have selected a pulse signal as an output, you must configure the timer for the pulse.
 - a. Go to *Engine* and select *Speed Monitoring*.
 - b. Configure the *Idle Mode Pulse Time*.
4. Go to *Engine* and select *Speed Monitoring*.
5. Configure the *Startup Idle Mode Time* timer.

Idle mode is activated when the engine starts. The under-voltage, under-frequency, and under-speed protections are not active during idle running.

The engine operates in idle mode until the *Startup Idle Mode Time* timer expires. When this timer expires, the *Idle to Rated Delay Time* timer starts. The genset ramps up, and operates at nominal speed when the *Idle to Rate Delay Time* timer expires. The under-voltage, under-frequency, and under-speed protections are also activated.

If the controller is in manual mode during idle running, and you push the start button, the controller stops the idle running, and starts to ramp up the genset.

Stop sequence for idle mode

You can also activate idle mode during the stop sequence. Go to *Engine > Speed Monitoring > Stopping Idle Time* to configure the timer for the idle stop time. If you set the timer to 0 seconds, idle mode is not activated during the stop sequence. The under-voltage, under-frequency, and under-speed protections are not active in idle mode.

When the stop sequence for the genset is activated, the *Stopping Idle Time* timer starts. When the timer expires, the genset stops.



More information

For parameters, see [Speed Monitoring](#).

8.5 Coolant temperature control

You can use the controller to control the coolant temperature of the engine.

By default, the engine coolant temperature is not enabled. To use this function, you must configure an analogue input as a temperature sensor or use the Engine Control Unit (ECU).

Configure the coolant temperature sensor with the smart connect software

1. If you use an analogue input:
 - a. Go the *Analogue Inputs* tab and select one of the analogue inputs.
 - b. For *Use input As* select *Engine Coolant Temperature Sensor* in the drop-down list.

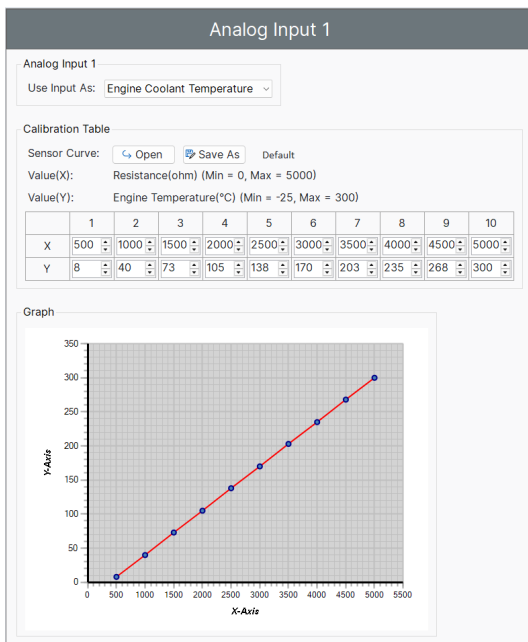

- c. Configure the calibration table values. To add a custom sensor curve, click the *Open* button, and select your file.
2. If you use an ECU:
 - a. Go to the *ECU Configuration* tab and select *Engine Control Unit (ECU)*.
 - b. For *Engine type* select the correct ECU. Do not select *Conventional*.
 - c. Make sure that *Coolant Temperature* is *Enabled*.

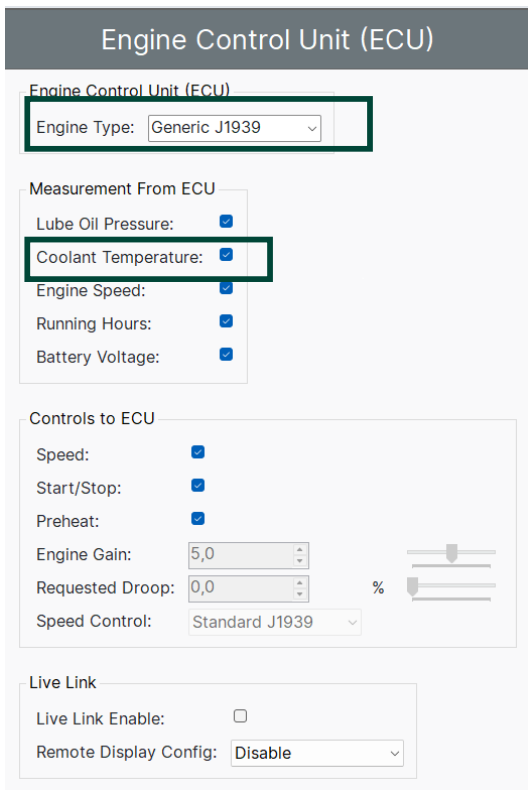

3. Go to the *Digital Outputs* tab and select the output you want to use.
4. Use the drop-down list next to the output to select *Coolant Temperature Control* as the source.

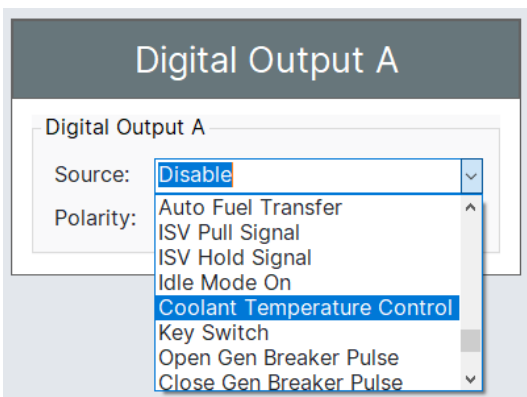

5. Go to the *Engine* tab and select *High Engine Coolant Temperature*.
6. Make sure that *Enable* is *Enabled*.
7. For *Temperature Control*, use the drop-down list to select *Heater Control* or *Cooler control*.
8. Configure the ON and OFF threshold.

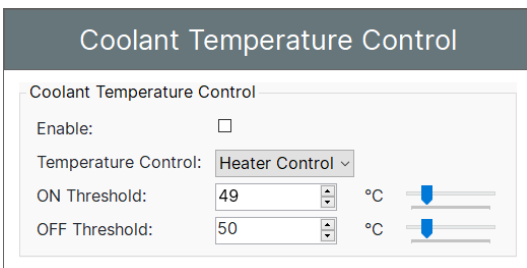

Heater control

When the coolant temperature is less than the *ON Threshold* value, the output is on. When the coolant temperature is more than the *OFF Threshold* value, the output is off.

Cooler control

When the coolant temperature is more than the *ON Threshold* value, the output is on. When the coolant temperature is less than the *OFF Threshold* value, the output is off.

8.6 Engine pre-heater

This function is used to control the temperature of the engine before the engine starts. The function is only active when the engine is stopped. A temperature sensor is used to activate an external heating system to keep the engine at a minimum temperature.

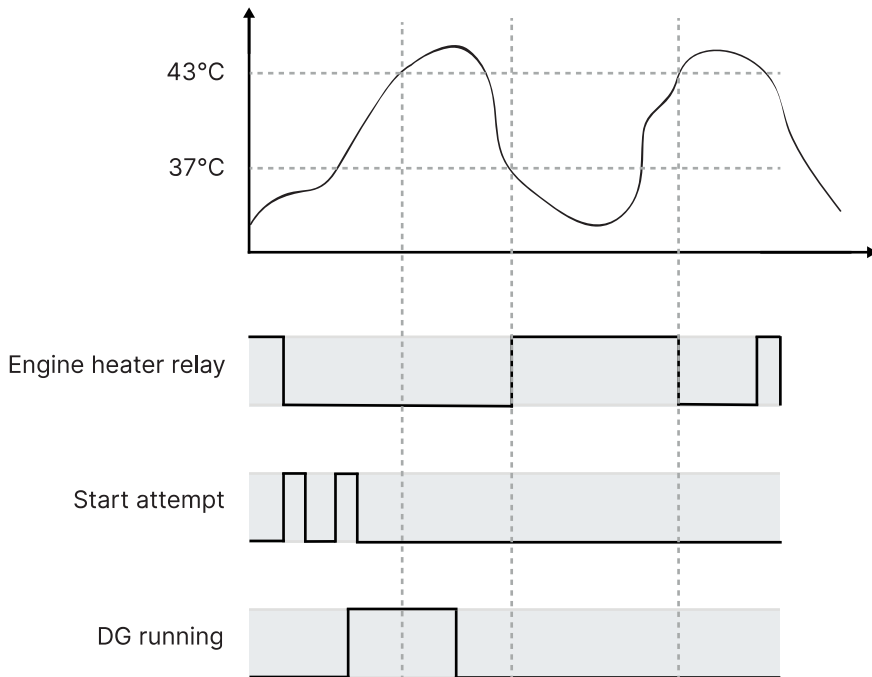

The function includes a set point and a hysteresis. In the example, the set point is 40 °C with a hysteresis of 3 °C. The controller opens the engine heater relay when the engine has reached 43 °C and closes when the engine temperature is 37 °C. You must select a relay for the engine heater. If the engine heater is active, and the manual control command has been activated, the engine heater relay is opened. When the command is activated again, the heater relay closes if the temperature is below the set point.

Configure the preheat function

1. Go to *Analogue Inputs* and select one of the analogue inputs.
2. Set the *Use Input As* to *Engine Coolant Temperature Sensor*.
3. Go to *Digital Outputs*, select one of the digital outs, and set the source as *Preheat Output*.
4. Go to *Engine* and then select *Preheat*.
5. Configure the preheat parameters.

Preheat

Preheat

Preheat Timer: 10 Sec

Engine Coolant Temperature:

Engine Coolant Temp Threshold: 25 °C

**More information**

For parameters, see [Preheat](#).

8.7 External EGR monitoring

The SGC supports monitoring of an external EGR system via status feedback from the engine ECU. The ECU controls the EGR system. The SGC monitors the ECU EGR status and reacts by generating warnings and (if the fault persists) a shutdown.

NOTE EGR supervision is available only when the EGR digital input is configured and the engine is running with the fuel relay active.

**More information**

For more information, see [Status monitoring](#), [M-logic](#), [Digital input](#) and [Modbus communication](#).

8.7.1 EGR fault detection

This flowchart shows how the controller determines the EGR operational state during engine operation and when an EGR fault warning is generated.

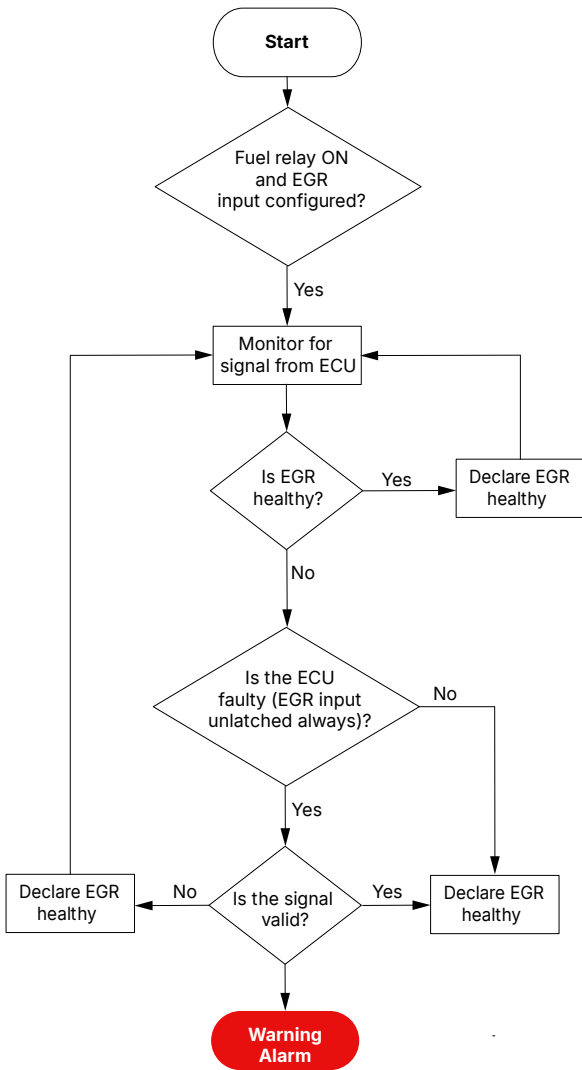

8.7.2 EGR fault supervision

An EGR Fault Warning is triggered when an EGR-related fault is detected. If the EGR-related fault persists and the supervision time exceeds 72 hours, an EGR Fault Shutdown is triggered.

A fault timer starts once any EGR fault is received, and the timer continues while the SGC remains in an EGR alarming condition, supervising the duration of the fault up to the shutdown delay. When the fault condition clears, the SGC starts a heal timer with a duration of 40 hours to monitor the stability of the healthy state. If the EGR alarm remains inactive for the entire heal monitoring period, the controller resets both the fault and heal timers.

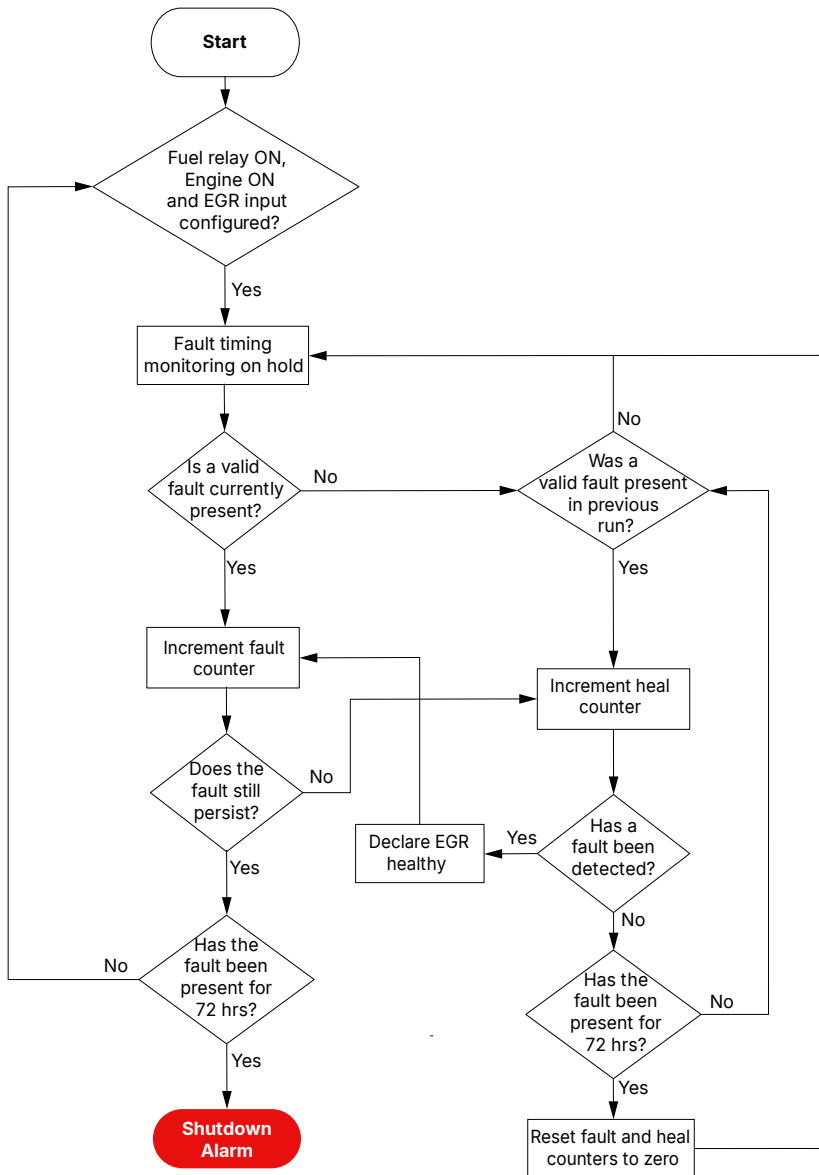

NOTE If an EGR Fault Shutdown is active, the controller stops the engine according to the configured shutdown action strategy.

8.8 Other functions

8.8.1 Maintenance timer

The controller has one timer to monitor maintenance intervals.

The timer function is based on engine running hours or a due date. When the adjusted timer expires, the controller displays an alarm.

To configure the maintenance timer, push and hold the *Stop* button to go to the Configuration menu. Select *Maintenance*.



More information

For parameters, see [Maintenance](#).

8.8.2 Keyswitch

Output function

You can configure the keyswitch function with the smart connect software. Go to *Digital Outputs* and configure one of the outputs as *Keyswitch*.

Wiring

Wire the keyswitch relay output to the ECU power. When the relay is open, the ECU has no power.

How it works

For the first 5 seconds after the SGC controller is powered on, the keyswitch relay is open.

How the keyswitch functions works:

1. There is an engine stop command.
2. The *Cooling down* timer starts.
3. When the cooling down timer expires, the SGC starts the *Extended stop* timer, and opens the keyswitch relay.
4. The relay is open until the extended stop timer expires.

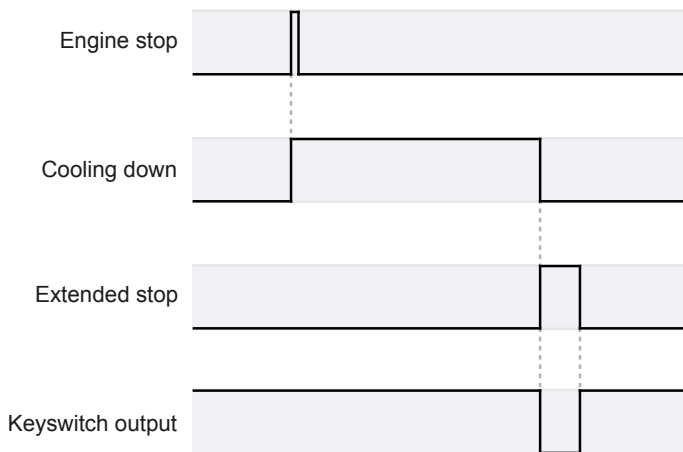

9. Modbus

9.1 About

The SGC controller supports a custom protocol based on the standard Modbus over an RS-485 layer. The controller operates in a server mode and responds to commands received from an external Modbus client.

This document will only describe the information required to communicate with the controller using the Modbus protocol. For more information about Modbus in general and the Modbus protocol, see the documentation freely available at <http://www.modbus.org>.

See the Modbus tables, available for download at www.deif.com, to see how the controller data is mapped to the Modbus addresses.

9.2 Connection details

The controller uses Modbus RTU as the transmission mode.

Byte format for communication

- Start bit: 1
- Data bits: 8
- Parity: None
- Stop bit: 1
- Cyclic Redundancy Check (CRC)

Setting up Modbus communication

1. Connect the controller terminals 31 and 32 to the SMPS terminals A and B.
 - Use a Belden 3105A cable or equivalent, 24 AWG (0.5 mm²) twisted pair, shielded, impedance 120 Ω, <40 mΩ/m, min. 95 % shield coverage.
2. Connect the controller terminal 30 to the ground of the SMPS. If the SMPS does not have a ground connection, leave terminal 30 open.
 - Use a two-core shielded cable for the connection.
3. Find the server ID from the SMPS and configure the same ID on the controller.
4. Enable the controller on the SMPS.

NOTE Do not use multi-strand wires for the connections.

9.3 RS-485 communication settings

- Server ID: 1 to 247
- Baud rate: 1200/2400/4800/9600/19200/38400/57600/115200 bps
- Parity: None/Even/Odd
- Stop bit: 1, 2
- Recommended polling frequency: 50 Hz
- No response timeout: 250 ms

9.4 EGR Modbus communication

The SGC makes EGR monitoring information available via Modbus communication. This includes EGR status, fault conditions, and supervision timer values.

These values allow external systems to:

- Monitor the EGR ECU condition
- Detect EGR-related faults
- Track fault and heal supervision timers
- Identify EGR-related shutdown status

EGR information is available in *Modbus registers 159 to 162*.



More information

For a complete list of registers, bit definitions, and data formats, see the SGC 420 Mk II Modbus tables.

10. CAN bus engine communication

10.1 Overview

10.1.1 About

There can be CAN bus communication between SGC controller and several engine types.

The SGC controller receives information from the Engine Control Unit (ECU) of the engine. The controller can use the information as input for its own control functions. The SGC can also use the information as display values, alarms, and as values to be transmitted through Modbus. If the ECU allows it, the SGC can send telegrams with commands and set points.

You can read the engine data from the SGC over Modbus. See the **Modbus tables** for more information.

NOTE See the ECU user manuals for the ECU protocol technical description and details of each communication value.

Default settings

The SGC is delivered with a set of default settings for engine communication. These settings are not necessarily correct for your engine or genset. Check all the settings before you operate the engine or genset.

Other engines and controllers

For engines and controllers not listed in this document, contact DEIF.



More information

See [SGC Mk II Engine communication](#) for supported engines.

10.1.2 Show engine values in the display

You can configure the SGC controller to show values from the ECU on the display.

Default view configuration

Use the Smart connect software to configure the ECU values you want to display on the controller. Go to `Engine > Engine Control Unit (ECU)` to configure the values.

To see the ECU display view on the controller, push the down  button and hold for 3 seconds. To exit the ECU display views, push and hold the down button for 3 seconds. The ECU view pages are only shown if you have configured the ECU parameters.

10.2 Configuration of the engine communication settings

Use the smart connect software to configure the engine communication settings for the SGC controller. Open the smart connect software and connect to the SGC controller.



More information

See [ECU Configuration](#) for engine communication settings.

10.3 Generic J1939

Most of the engine communication protocols are based on SAE J1939. J1939 is a very large standard, and most of it is irrelevant to engine communication. The SGC supports only relevant parts of J1939.



More information

See [SGC Mk II Engine communication](#) for more information.

11. Inputs and outputs

11.1 Digital inputs

No.	Source	Description
1	Alternate Nominal Switch	When this input is activated, the default nominal settings switch to the alternative nominal settings.
2	Auto Restore Inhibit	If this input is activated, the controller does not automatically restore operation after a fault or shutdown condition has been cleared.
3	Auto Start Inhibit	When this input is activated, automatic start of the genset is blocked. Manual start commands are not affected.
4	Battery Charger Failure	This input is activated when there is a battery charge failure and the mains is OK. An alarm occurs and the controller initiates the configured action, for example, a warning.
5	Close Gen/Open Mains Switch	The genset breaker closes and the mains breaker opens when this input is activated. The genset must be running.
6	Close Mains/Open Gen Switch	The genset breaker opens and the mains breaker closes when this input is activated. The genset must be running.
7	Egr Digital In	This input is used to receive a digital signal related to the Exhaust Gas Recirculation (EGR) system status or control from the ECU.
8	Emergency Stop	When this input is activated, the controller stops the genset immediately without a cool down period.
9	External Auto Panel lock	The controller changes the running mode to AUTO and locks the display. The operator cannot use the display.
10	Gen Contactor Latched	When this input is activated, the genset breaker closes and the mains breaker opens.
11	Generator Load Inhibit	When this input is activated, the generator cannot take the load. If the genset is operating when the input is activated, then genset cools down and stops.
12	High Engine Coolant Temp Switch	The input is activated when the engine coolant temperature is more than the configured value. The configured alarm is shown. You can configure the alarm type.
13	Idle Mode Enable	You can activate idle mode with this input.
14	Kohler ECU Reset	When this input is activated, a reset command is sent to the Kohler ECU, restarting ECU communication and clearing ECU-related faults if possible.
15	Load Takeover	When this input is activated, the controller allows the generator to take over the load, bypassing normal transfer sequence conditions.
16	Low Fuel LVL Switch	The input is activated when the fuel level is less than the configured value. The configured alarm is shown.
17	Low Lube Oil Press Switch	The input is activated when the lube oil pressure is less than the configured value. The configured alarm is shown.
18	Low Water LVL Switch	The input is activated when the water level is less than the configured value. The configured alarm is shown.
19	Mains Contactor Latched	When this input is activated, the mains breaker closes and the genset breaker opens.
20	Mains Load Inhibit	When this input is activated, the mains cannot take the load.
21	Not Used	The digital input is not used.
22	Regeneration SW inhibit signal	This is an input for CAN bus.





No.	Source	Description
23	Remote Alarm Mute	Mutes all present alarms, and the alarm LED on the display stops flashing.
24	Remote alarm Ack	Acknowledges all present alarms, and the alarm LED on the display stops flashing.
25	Remote Start/Stop	This input initiates the start or stop sequence of the genset when the controller is in AUTO mode.
26	Shutdown Override Switch	When this input is activated, shutdown conditions configured as overridable are ignored.
27	Simulate Auto Button	Initiates AUTO mode-related sequences depending on mains and load conditions.
28	Simulate Mains Healthy	Simulates mains return behavior in AUTO or manual mode.
29	Simulate Start Button	Initiates the start sequence of the genset in manual mode.
30	Simulate Stop Button	Initiates the stop sequence of the genset in manual mode.
31	Smoke Fire	When this input is activated, an alarm occurs and the configured action is initiated.
32	Stop and Panel Lock	Stops the genset and locks the display when activated.
33	User Configured	The digital input is configured by the user.
34	V-belt Broken Switch	When this input is activated an alarm is shown on the display.



11.2 EGR digital input

The EGR digital input serves as feedback from the engine ECU. Based on the input signal, the SGC determines whether the EGR ECU condition is healthy or faulty.

EGR signal interpretation

The table below describes the ECU feedback signals, the detected condition, and the recommended action.

Fault description	ECU feedback / signal description	Error code pattern	Recommended action
EGR ECU			
ECU healthy	1 LOW signal, then continuous HIGH		No action
ECU faulty	No signals (constant level)		Replace EGR ECU
Temperature sensor			
Temp sensor fault	2 LOW signals, repeat (3 s delay)		Replace sensor
Temp sensor out	3 LOW signals, repeat (3.5 s delay)		Check installation
EGR valve			
Valve wire open	4 LOW signals, repeat (3.5 s delay).		Replace valve

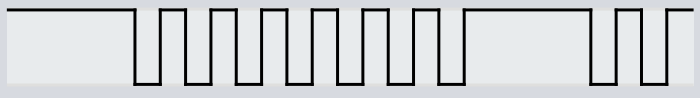
Fault description	ECU feedback / signal description	Error code pattern	Recommended action
Valve sensor fault	5 LOW signals, repeat (3.5 s delay)		Replace valve
Valve not lifting	6 LOW signals, repeat (3.5 s delay)		Replace valve
Valve not closing	7 LOW signals, repeat (3.5 s delay)		Replace valve



NOTE

The ECU triggers an error, if this condition lasts more than 4 minutes.

Digital input configuration

The EGR input is intended for *open-to-activate* polarity for all digital inputs except Digital input I.

If the EGR input is configured but the ECU is not connected (open circuit at the pin), the SGC receives a flat signal that is always high and assumes that the ECU is healthy. Open-circuit detection is not available for Digital inputs A to G.

Two workarounds are available to ensure correct EGR fault detection:

1. Use Digital input H or I
 - Digital input H: Configure with *open-to-activate* polarity.
 - Digital input I: Configure with *close-to-activate* polarity, as this input operates with inverted polarity.
2. Use an interposing relay

Configure the digital input with *close-to-activate* polarity and install an interposing relay to invert the EGR signal before it is connected to the SGC. With this configuration, an open circuit is interpreted as an inactive signal, and the controller declares the EGR ECU as faulty.



NOTE

For more information, see [External EGR monitoring](#).

11.3 Digital outputs

No.	Output source	Description
1	Auto Fuel Transfer	Automatic fuel transfer is activated when you activate this output.
2	Auto Mode	This output is activate when the controller is in AUTO mode.
3	Battery Over Volt	This output is activated when there is an active alarm for battery over-voltage.
4	Battery Under Volt	This output is activated when there is an active alarm for batter under-voltage.
5	BTS Battery Hybrid Mode	The output is activated when the load is on the site battery and the engine has stopped (no failure).
6	Calling For Scheduler Run	This output is activated when the controller is in exercise mode.
7	Charge Alt Shutdown	This output is activated when there is an active shutdown alarm for charge failure.
8	Charge Alt Warning	This output is activated when there is an active warning alarm for charge failure.

No.	Output source	Description
9	Close Gen Breaker Pulse	This output is activated when a pulse is generated to close the genset breaker
10	Close Gen Contactor	This output is activated when the digital input for close genset/open mains is activated in manual mode.
11	Close Mains Breaker Pulse	This output is activated when a pulse is generated to close the mains breaker
12	Close Mains Contactor	This output is activated when the digital input for close mains/open genset is activated in manual mode.
13	Common Alarm	This output is activated when one of the alarm types is activated.
14	Common Electrical trip	This output is activated when there is an active electrical trip alarm.
15	Common Shutdown	This output is activated when there is an active shutdown alarm.
16	Common Warning	This output is activated when there is an active warning alarm.
17	Cooling Down	This output is activated when the cooldown period of the genset is initiated. The output is activate for the duration of the period.
18	Custom Logic Out [1 to 5]	This output is activated according to the configured custom logic conditions defined in the controller.
19	Dig In [A to P]	This output is activated when digital input [A to P] is activated.
20	Disable	The output is not used.
21	Emergency Stop	The output is activated when the emergency stop is activated.
22	External Auto Panel Lock	This output is activated when the input for external panel lock is active.
23	Fail To Close Generator	This output is activated when there is a genset breaker failure.
24	Fail To Close Mains	This output is activated when there is a mains breaker failure.
25	Fail To Start	This output is activated when the fail to start alarm is activated.
26	Fail To Stop	This output is activated when the fail to stop alarm is activated.
27	Fuel Relay	This output is activate when the fuel relay is active.
28	Gen Available	This output is activated when the timer for the warm up delay expires.
29	Gen Over Current	This output is activated when the controller shuts down the genset because of over-current.
30	Gross Over Spd Shutdown	This output is activated when the shutdown alarm for gross overspeed is activated.
31	High Engine Coolant Temp	This output is activated when the alarm for high engine temperature is activated.
32	Idle Mode Off Pulse	This output is activated when a pulse is generated to deactivate idle mode.
33	Idle Mode ON	This output is activated when the genset is operating at low idle speed.
34	Idle Mode On Pulse	This output is activated when a pulse is generated to activate idle mode.
35	Inducement Buzzer	This output is activated to drive an audible buzzer when an inducement or warning condition is active.
36	ISV Hold Signal	This output is activated when start command is given. The output is active until the engine has stopped.
37	ISV Pull Signal	This output is activated when a start command is given.
38	Key Switch	This output is activated when the controller enables the engine ignition or key switch function.
39	Kohler ECU Power	This output supplies power to the Kohler ECU when the controller requires the ECU to be powered.

No.	Output source	Description
40	L1 Phase OV Shutdown	This output is activated when the over-voltage shutdown alarm for phase L1 is activated.
41	L1 Phase UV Shutdown	This output is activated when the under-voltage shutdown alarm for phase L1 is activated.
42	L2 Phase OV Shutdown	This output is activated when the over-voltage shutdown alarm for phase L2 is activated.
43	L2 Phase UV Shutdown	This output is activated when the under-voltage shutdown alarm for phase L2 is activated.
44	L3 Phase OV Shutdown	This output is activated when the over-voltage shutdown alarm for phase L3 is activated.
45	L3 Phase UV Shutdown	This output is activated when the under-voltage shutdown alarm for phase L3 is activated.
46	Loading Freq Not Reached	This output is activated when the loading frequency has not reached the minimum set point during the start sequence.
47	Loading Volt Not Reached	This output is activated when the loading voltage has not reached the minimum set point during the start sequence.
48	Low Fuel LVL	This output is activated when the low fuel alarm is activated.
49	Low LOP	This output is activated when the low LOP alarm is activated.
50	Mains Failure	This output is activated when there is a mains failure.
51	Mains High Volt	This output is activated when the mains voltage is more than the configured value.
52	Mains Low Volt	This output is activated when the mains voltage is less than the configured value.
53	Maintenance Due	This output is activated when the maintenance alarm is activated.
54	Manual Mode	This output is activate when the controller is in manual mode.
55	MPU Loss	This output is activated when there is an MPU failure.
56	Open Gen Breaker Pulse	This output is activated when a pulse is generated to open the genset breaker.
57	Open Gen Contactor	This output is activated when the load is transferred to the mains or when close mains/open genset is activated.
58	Open Mains Breaker Pulse	This output is activated when a pulse is generated to open the mains breaker.
59	Open Mains Contactor	This output is activated when the load is transferred to the genset or when close genset/open mains is activated.
60	Over Freq Shutdown	This output is activated when the shutdown alarm for over-frequency is activated.
61	Over Speed Shutdown	This output is activated when the shutdown alarm for overspeed is activated.
62	Preheat Output	This output is activated when the pre-heater is activated. The output is active for the duration of the pre-heat timer.
63	(Res) Pressure Open Circuit	This output is activated when the alarm for oil pressure (open circuit) is activated.
64	Sounder Alarm	This output is high when an alarm is generated. The output is activate for the duration of the alarm.
65	Start Relay	This output is activated when the start relay is activated during the engine start sequence.

No.	Output source	Description
66	Stop and Panel Lock	The controller is powered OFF and the display buttons cannot be used.
67	Stop Mode	This output is activated when the stop sequence is initiated.
68	Stop Solenoid	This output is activated when the stop solenoid output is high.
69	Temp Sensor Open Circuit	This output is activated when the alarm for the temperature sensor (open circuit) is activated.
70	Temperature Control	This output is activated when the coolant temperature is outside the set points configured for the temperature.
71	Under Freq Shutdown	This output is activated when the shutdown alarm for under-frequency is activated.
72	Under-speed Shutdown	This output is activated when the shutdown alarm for under-speed is activated.

12. Remote Display Controller (RDC)

12.1 About RDC

The Remote Display Controller (RDC) is an SGC controller used as a remote display for an SGC master controller.

The RDC mirrors the master controller and gives access to operating values such as voltage, current, frequency, alarms, and system status. Depending on the configuration, the RDC can also be used to send control commands to the master controller. This enables monitoring and operation of the system from a remote location.

12.2 Connect the controllers

Connect the master controller and the remote display (RDC) using the CAN (J1939) interface.

Typical CAN connection between the master controller and the RDC

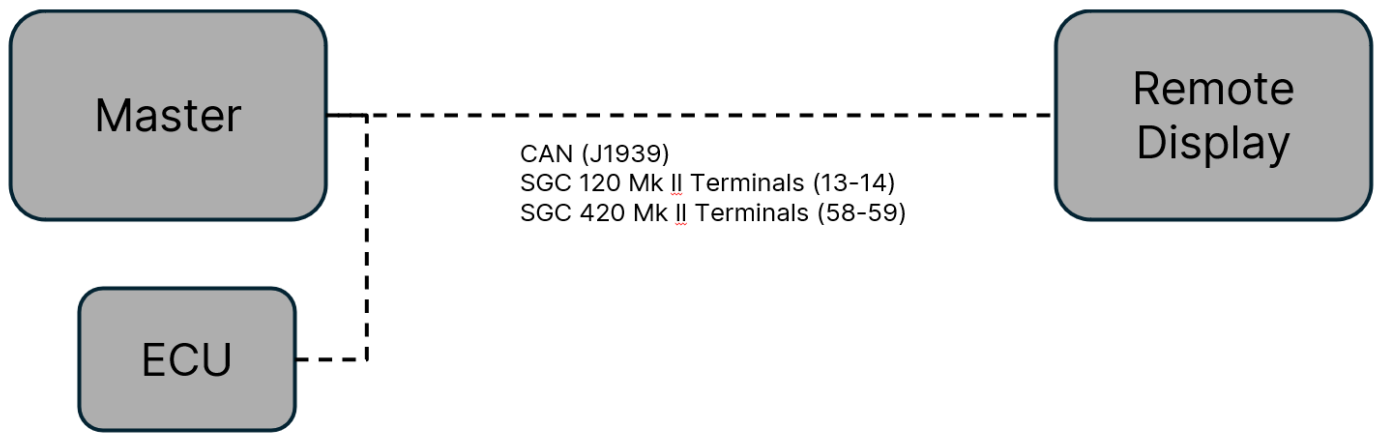

Examples of master controller and RDC configurations

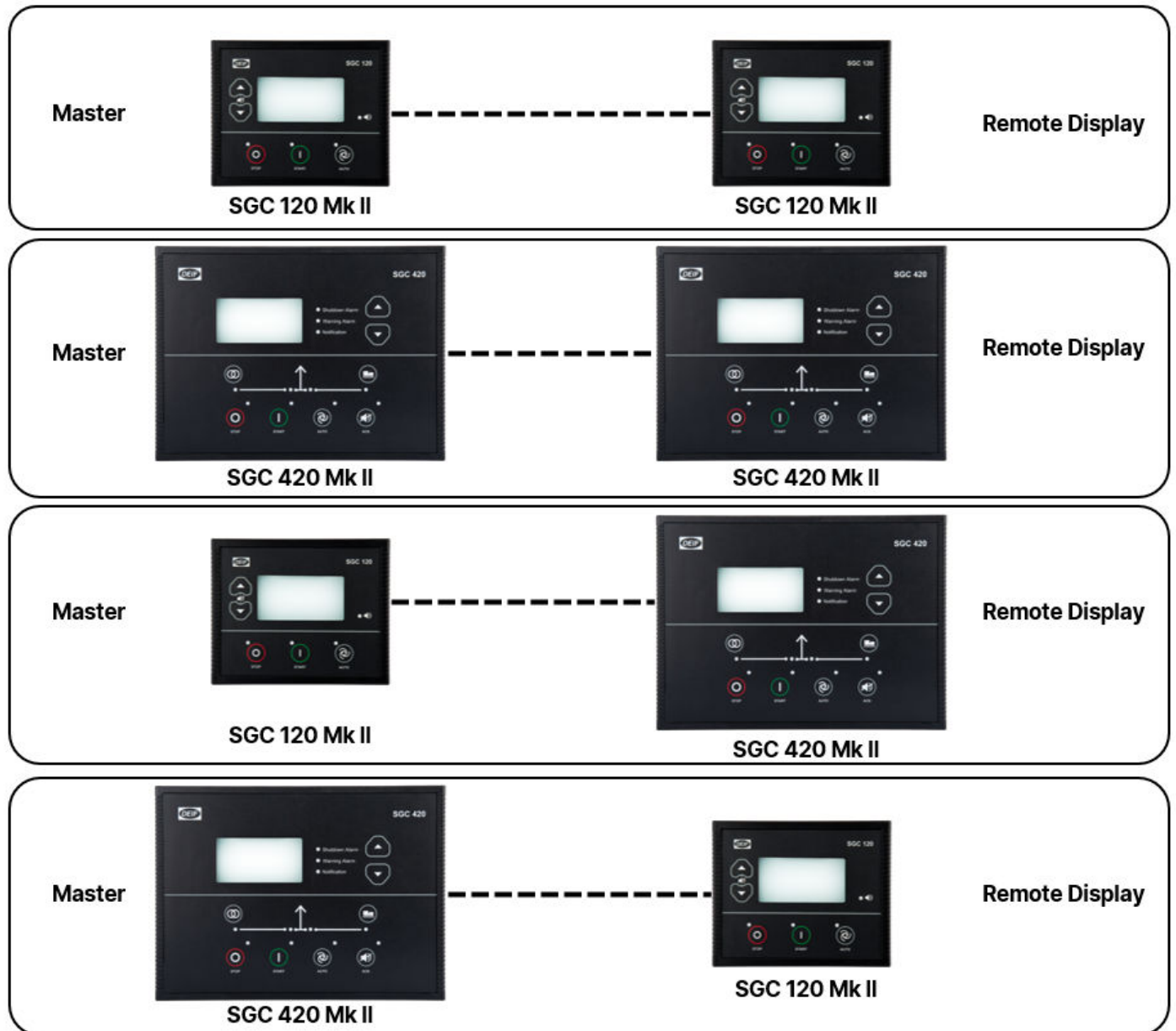

In an RDC setup:

- One SGC controller operates as the master controller.
- One SGC controller operates as the remote display (RDC).

12.3 Configure the controllers

12.3.1 Configure the master controller

Configure the master controller using *DEIF Smart Connect Mk II*.

Engine Control Unit (ECU)

Engine Control Unit (ECU)

Engine Type: Conventional

Measurement From ECU

Lube Oil Pressure:

Coolant Temperature:

Engine Speed:

Running Hours:

Battery Voltage:

Controls to ECU

Speed:

Start/Stop:

Preheat:

Engine Gain: 5,0

Requested Droop: 0,0 %

Speed Control: Standard J1939

Live Link

Live Link Enable:

Remote Display Config: View Mode

When RDC is used, *Live Link Enable* parameter must be enabled to allow generator related parameters such as voltage and frequency to be transmitted to and displayed on the remote display.

The *Remote Display Config* parameter defines how the RDC operates.

Setting	Description
Disable	The master controller does not connect to a remote display.
View Mode	The remote display (RDC) displays operating values, alarms, and status information received from the master controller. Control commands are not accepted by the master controller.
Control Mode	The remote display (RDC) displays operating values, alarms, and status information received from the master controller. Control commands such as Start, Stop, and operating mode selection are accepted by the master controller.



More information

For parameters, see [Engine Control Unit \(ECU\)](#).

12.3.2 Configure the remote display (RDC)

For the remote display, a universal application software (firmware) is available on the DEIF website as [SGC Remote Display RDC 100](#), this can be installed on any SGC variant using DEIF Smart Flash.

As RDC 100 is a universal firmware for the SGC series, any SGC controller can be made a remote display and configured using DEIF Smart Connect Mk II. No additional communication configuration is required for the RDC.

Language and diagnostics

The RDC uses the same language pack and DTC configuration as the master controller. If a customised language pack or DTC configuration is used on the master controller, the same files must be installed on the RDC.



More information

For more information, see [Language pack](#).

13. Troubleshooting

General troubleshooting

Fault	Action
The controller does not power ON.	<ul style="list-style-type: none"> • Check the battery voltage. • Check the fuse on the battery supply. • Check continuity between battery positive and controller terminal 2. • Check continuity between battery ground and controller terminal 1.
The controller display is not responding.	<ul style="list-style-type: none"> • Reset the controller power.
The controller fails to crank-start the engine.	<ul style="list-style-type: none"> • Check the battery voltage. • Go to the Configuration menu on the controller. Make sure the start output is configured correctly. Measure the output voltage to make sure the output is working. • Go to the Configuration menu on the controller. Make sure the crank disconnect method and the LLOP switch polarity are configured correctly. Make sure that the lube oil pressure switch and sensor are working correctly. Do a check of the wiring for the switch and sensor.
The emergency stop alarm is shown without the emergency stop is activated.	<ul style="list-style-type: none"> • Check if the Emergency stop switch is working correctly, including the wiring. • Enter the Configuration mode in the controller and verify the configuration of the Emergency stop polarity.
The controller generates unnecessary shutdown alarms or warning alarms.	<ul style="list-style-type: none"> • Check the respective switch, sensor and wiring. • Go to the Configuration menu. Make sure the threshold values for the alarms and warnings are configured correctly.
The controller shows <i>Charging Alt Fail</i> alarm.	<ul style="list-style-type: none"> • To check if the controller's charging alternator terminal is working: <ul style="list-style-type: none"> ◦ Disconnect the charging alternator wiring to the controller's terminal 10. ◦ Short the terminal 10 to the ground through a DC ammeter. ◦ Crank-start the engine. ◦ The DC ammeter should indicate the current in the range of 200 to 400 mA for ~30 seconds. ◦ If yes, the controller's charging alternator terminal is working correctly. • Disconnect and re-connect the charging alternator ind connection to the controller's terminal 10. • Check if the charging alternator is working corrctly.
The controller shows <i>Error C03</i> .	<p>Error C03 can occur if the controller is disconnected from the PC during a configuration.</p> <ol style="list-style-type: none"> 1. Push and hold the <i>Stop/Config</i>  button during a power cycle to reset the controller. 2. Re-send the configuration file.
<ol style="list-style-type: none"> 1. The controller shows the genset is ON while the genset is stopped. 2. The controller shows the <i>Fail to stop</i> alarm when the genset is at rest. 	<ul style="list-style-type: none"> • Go to the Configuration menu on the controller. Make sure the LLOP and LOP parameters are configured correctly. Check the wiring. • Make sure that the mains voltage wiring is not connected to the genset voltage terminals on the controller.
The controller sends a crank-start command immediately after power ON.	<ul style="list-style-type: none"> • Make sure the output terminal on the controller is not directly connected to the starter relay. The output on the controller should be connected to an intermediate relay. The intermediate relay should provide power to the starter relay. Failure to do this can cause permanent damage to the controller.

Fault	Action
	<ul style="list-style-type: none"> • Check start-relay connection to the terminal on the controller. • Go to the configuration menu on the controller. Make sure the start mode and start relay output polarity are configured correctly.
The engine runs, but the controller shows genset to be OFF.	<ul style="list-style-type: none"> • Check the alternator voltage signal (L1 phase) is received by the controller terminal. • Check if the LOP and LLOP are working correctly. Check the wiring to the controller.
The controller shows incorrect PF value or kW or load current.	<ul style="list-style-type: none"> • Check the wiring of the failing alternator phase voltage and the CT to the controller. • Check the CT ratio (if kW or current reading is faulty).
The controller shows incorrect mains voltage or incorrect main alternator voltage.	<ul style="list-style-type: none"> • Check the wiring of the failing phase to the controller.
The controller shows incorrect reading for any of LOP, fuel level or engine temperature sensors.	<ul style="list-style-type: none"> • Check respective sensor and its wiring. • Check the SCP wiring. • Go to the Configuration menu on the controller. Make sure the failing sensor is calibrated and configured correctly.

AUTO mode troubleshooting

Fault	Action
The controller shows incorrect engine RPM.	<ul style="list-style-type: none"> • Check the wiring of the main alternator's L1-phase and neutral to the controller.
The controller does not start the engine when a remote start command is sent from an external device.	<ul style="list-style-type: none"> • Check the wiring of the remote start signal to the digital inputs on the controller. • Go to the Configuration menu on the controller. Make sure the digital input for the remote start is configured correctly. • Make sure that the controller is in Auto mode. • Make sure that Mains monitoring is not enabled. • Make sure Site mode is not enabled.
Controller does not stop the engine when a remote stop command is sent from an external device.	<ul style="list-style-type: none"> • Check the wiring of the remote stop signal to the digital input on the controller. • Go to the Configuration menu on the controller. Make sure the digital input for the remote stop is configured correctly. • Make sure that the controller is in Auto mode.
While in auto mode, the controller sends a start command even if mains is present.	<ul style="list-style-type: none"> • Check the wiring of the mains L1, L2 and L3 phase to the inputs on the controller. • Go to the Configuration menu on the controller. Make sure the mains monitoring parameters are configured correctly.

Modbus troubleshooting

Fault	Action
The controller is not sending data using Modbus	<ul style="list-style-type: none"> • Make sure Modbus communication is enabled in the controller. • Make sure the Modbus communication settings of the serve match with the client. • Make sure the Modbus connections are wired correctly (terminals 31 and 32). • Check if the connections are interchanged. • Check the 120 Ω resistance between terminal A (terminal 31) and terminal B (terminal 32).

Site battery monitoring troubleshooting

Fault	Action
The site voltage is not consistent	<ul style="list-style-type: none"><li data-bbox="571 185 1187 219">• Make sure the panel and site are correctly earthed.<li data-bbox="571 226 1394 259">• Make sure the connections are wired correctly (terminals 24 and 25).