

AGC-4 Mk II

Generator, Mains, BTB, Group, and Plant
Operator's manual

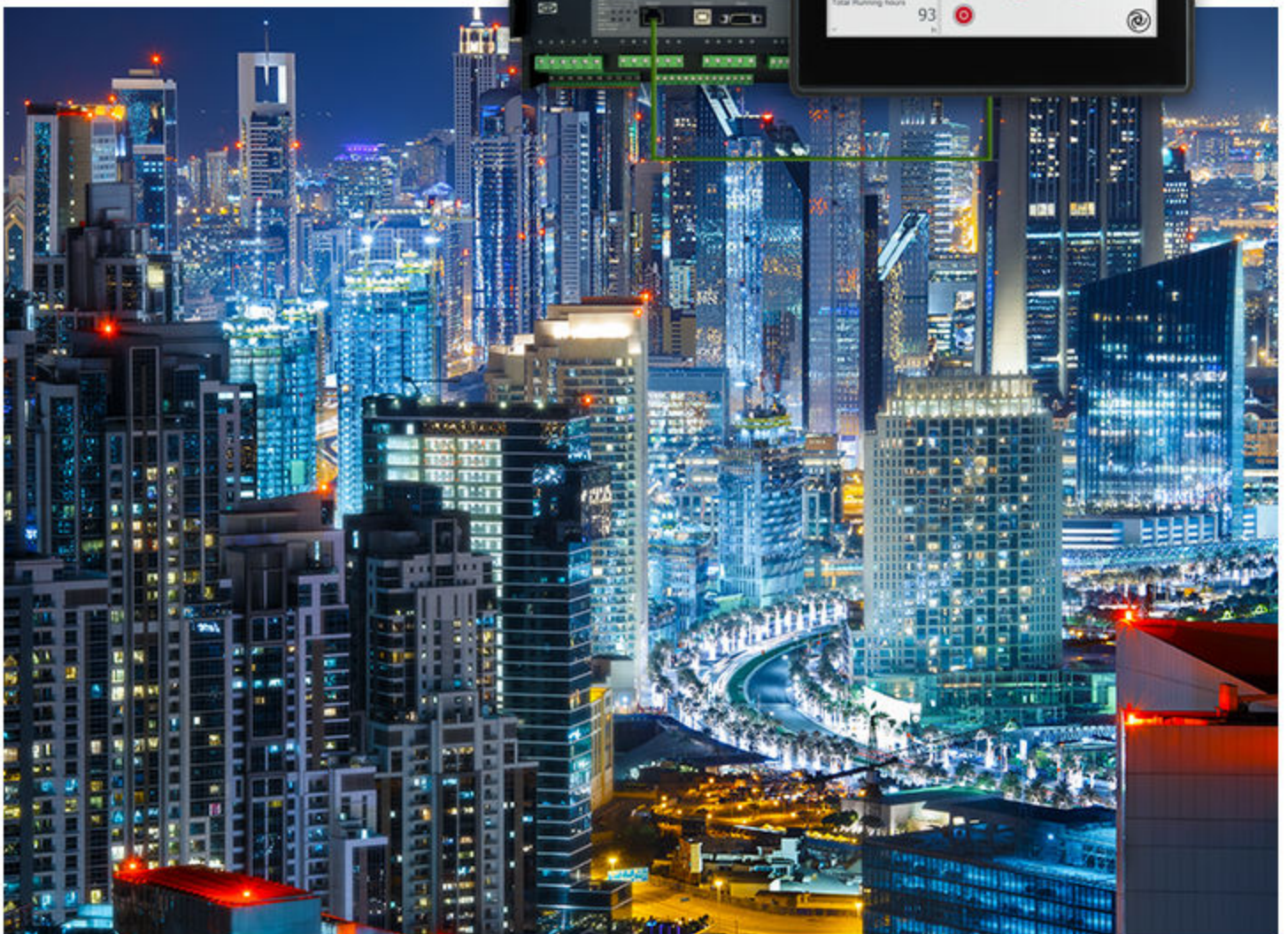

1. General information

1.1 About the Operator's manual.....	3
1.2 Warnings, safety and legal information.....	3
1.2.1 Warnings and notes.....	3
1.2.2 Factory settings.....	4
1.2.3 Legal information and disclaimer.....	4

2. DU-2 buttons and LEDs

2.1 Display layouts for AGC-4 Mk II.....	5
2.2 Button functions.....	8
2.3 Modes.....	10
2.4 LED functions.....	11
2.4.1 LED colour schemes.....	12

3. LCD display and menus

3.1 LCD display.....	13
3.2 Menus.....	13
3.2.1 Entry window.....	13
3.3 Password management.....	14
3.3.1 Parameter access.....	15
3.4 Setup.....	15
3.5 Views.....	16
3.5.1 Configurable views V1 and V2.....	16
3.5.2 Dynamic view V3.....	17
3.5.3 View menu example.....	17
3.6 Status texts.....	18
3.7 Alarm handling.....	23
3.7.1 Self-check errors.....	23
3.8 Log list.....	24

4. Maintenance and disposal

4.1 Maintenance.....	25
4.2 Disposal of waste electrical and electronic equipment.....	25

1. General information

1.1 About the Operator's manual

This AGC-4 Mk II Operator's Manual describes the DU-2 display unit buttons and LEDs, LCD display, alarm handling and the log list.

A TDU can be used instead of a DU-2. This touch screen display unit has its own operator's manual.



CAUTION



Read this manual

Read this manual before you operate the system. Failure to do this may result in personal injury and damage to the equipment.

Software version

This document is based on the AGC-4 Mk II software version 6.23.0.

NOTE In software version 6.20, MANUAL mode was changed to NO REGULATION, and SEMI-AUTO mode was changed to MANUAL.

1.2 Warnings, safety and legal information

1.2.1 Warnings and notes

Throughout this document, a number of warnings and notes with helpful user information will be presented. To ensure that these are noticed, they will be highlighted as follows in order to separate them from the general text.

Warnings



DANGER!



This shows dangerous situations.

If the guidelines are not followed, these situations will result in death, serious personal injury, and equipment damage or destruction.



WARNING



This shows potentially dangerous situations.

If the guidelines are not followed, these situations could result in death, serious personal injury, and equipment damage or destruction.



CAUTION



This shows low level risk situation.

If the guidelines are not followed, these situations could result in minor or moderate injury.

NOTICE



This shows an important notice

Make sure to read this information.

Notes

NOTE Notes provide general information, which will be helpful for the reader to bear in mind.

1.2.2 Factory settings

The controller is delivered pre-programmed from the factory with a set of default settings. These settings are based on typical values and may not be correct for your system. You must therefore check all parameters before using the controller.

1.2.3 Legal information and disclaimer

DEIF takes no responsibility for installation or operation of the generator set or switchgear. If there is any doubt about how to install or operate the engine/generator or switchgear controlled by the Multi-line 2 unit, the company responsible for the installation or the operation of the equipment must be contacted.

NOTE The Multi-line 2 unit is not to be opened by unauthorised personnel. If opened anyway, the warranty will be lost.

Disclaimer

DEIF A/S reserves the right to change any of the contents of this document without prior notice.

The English version of this document always contains the most recent and up-to-date information about the product. DEIF does not take responsibility for the accuracy of translations, and translations might not be updated at the same time as the English document. If there is a discrepancy, the English version prevails.

2. DU-2 buttons and LEDs

2.1 Display layouts for AGC-4 Mk II

NOTE The display dimensions are H × W = 115 × 220 mm (4.528" × 8.661").

Engine and generator breaker control (island) (option Y1)

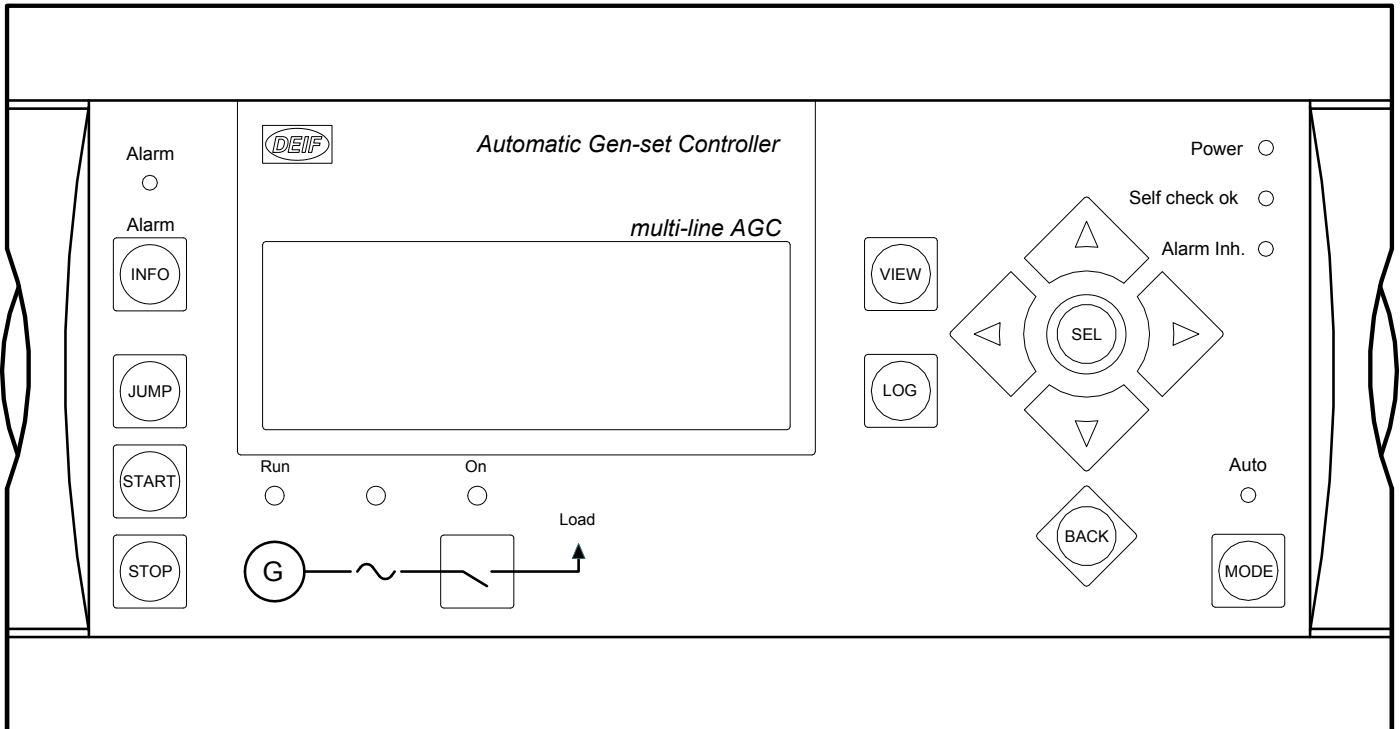

Generator breaker and mains breaker control (option Y3)

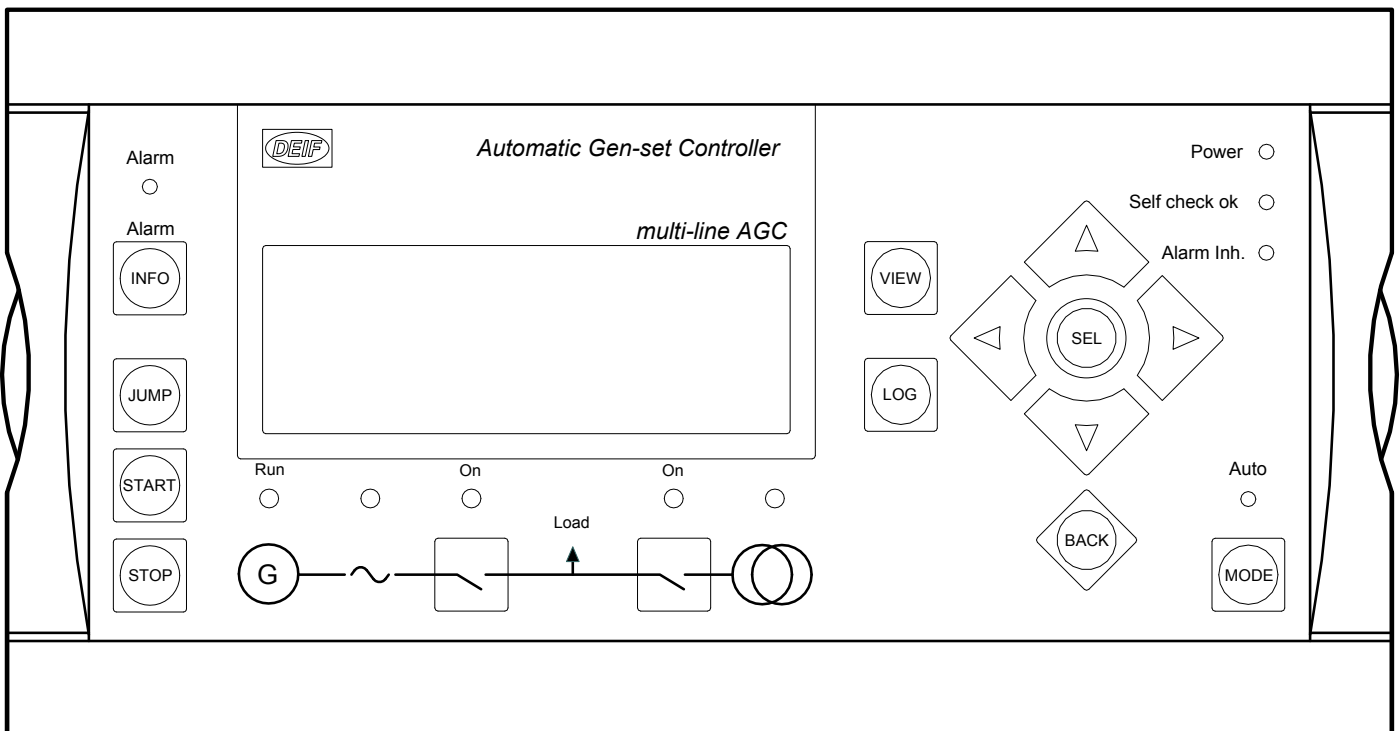

Tie breaker and mains breaker control (option Y4)

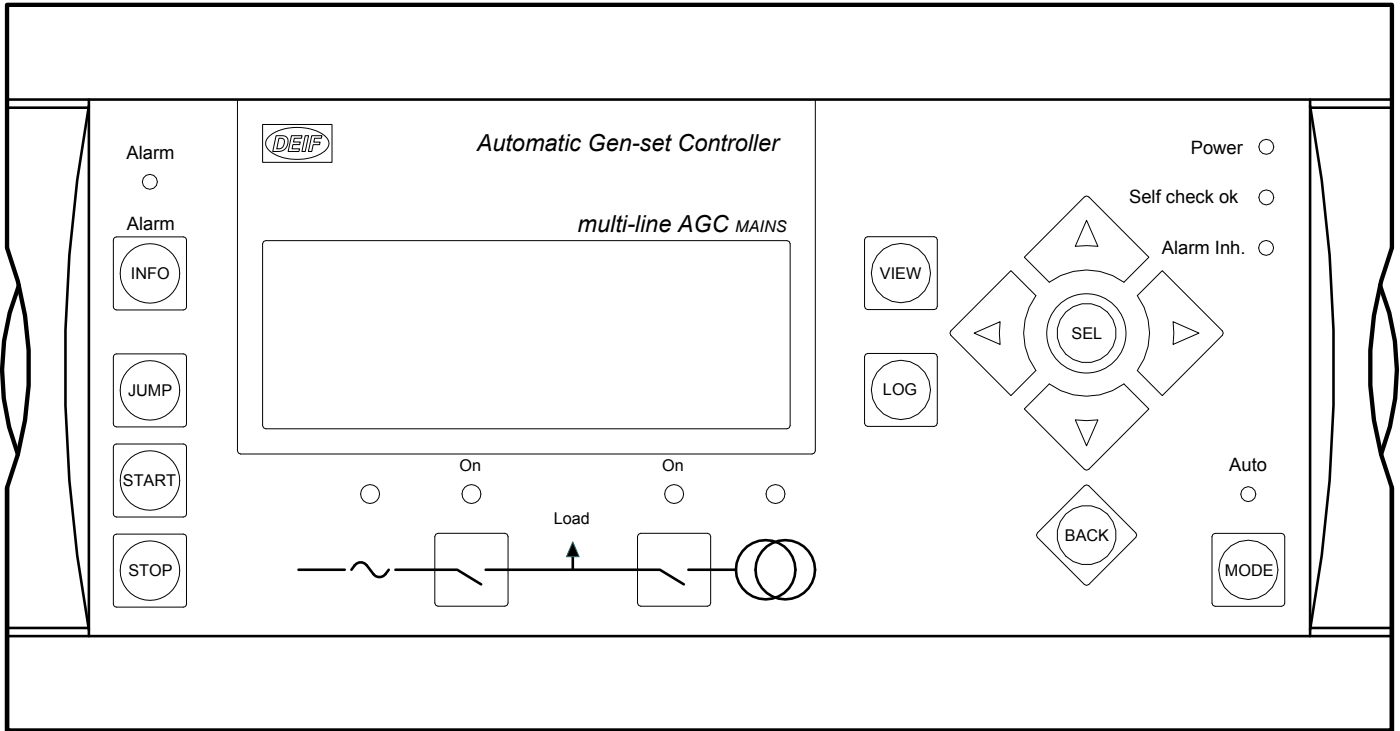

Bus tie breaker control (option Y5)

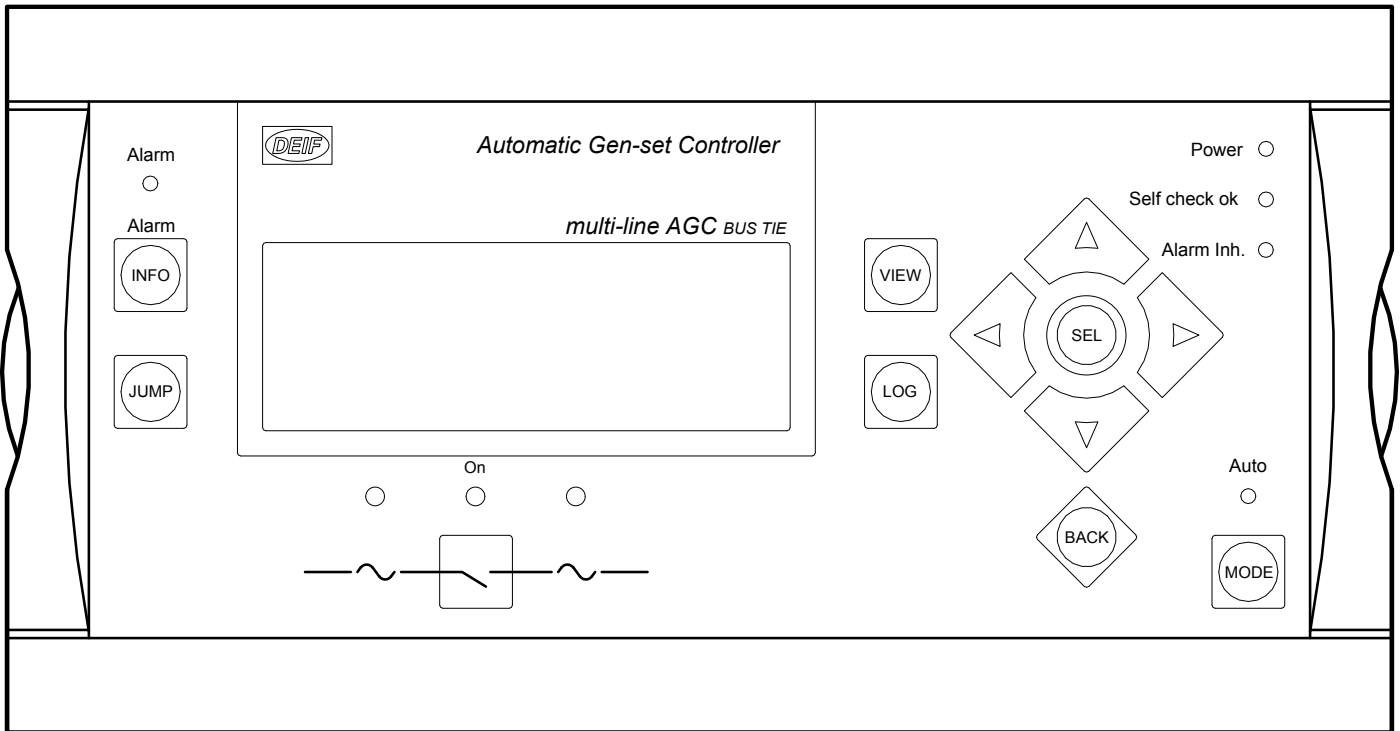

Group control (option Y8)

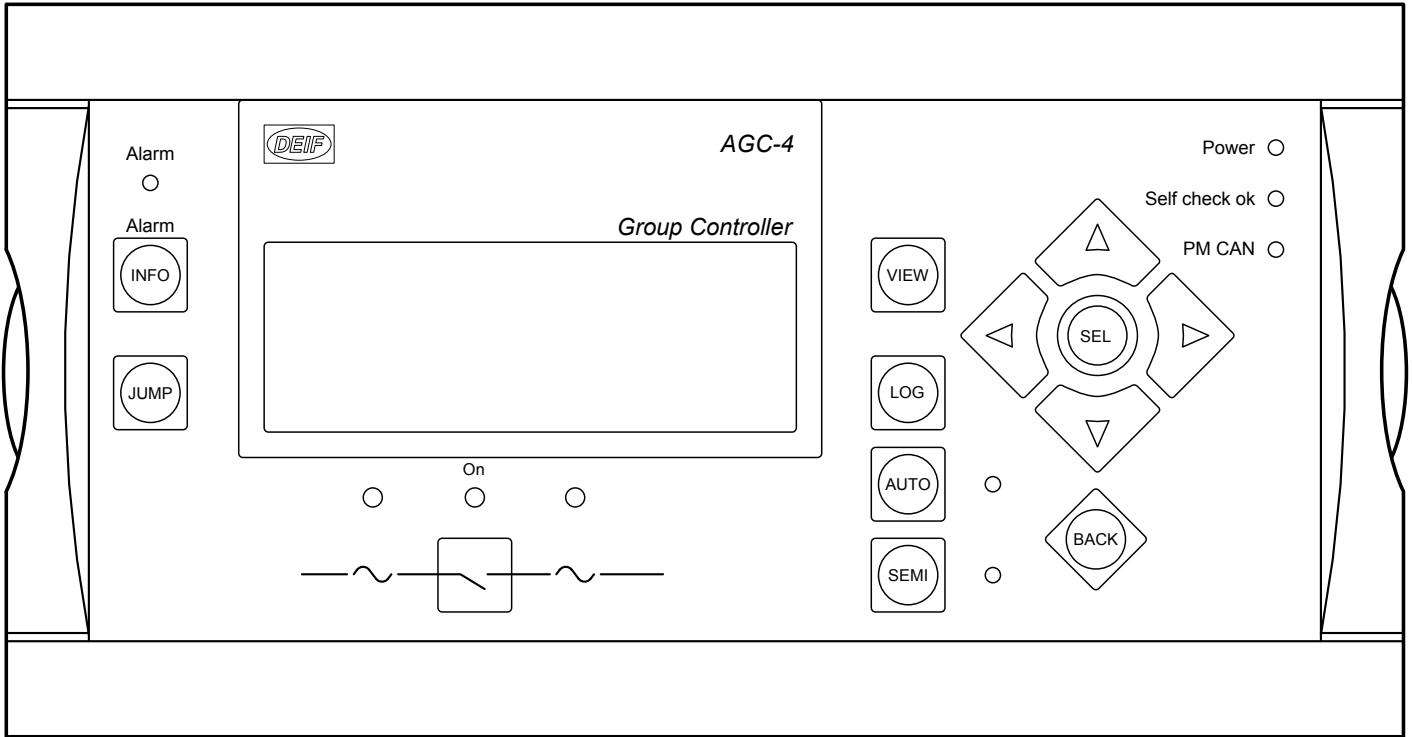

Plant control (option Y9)

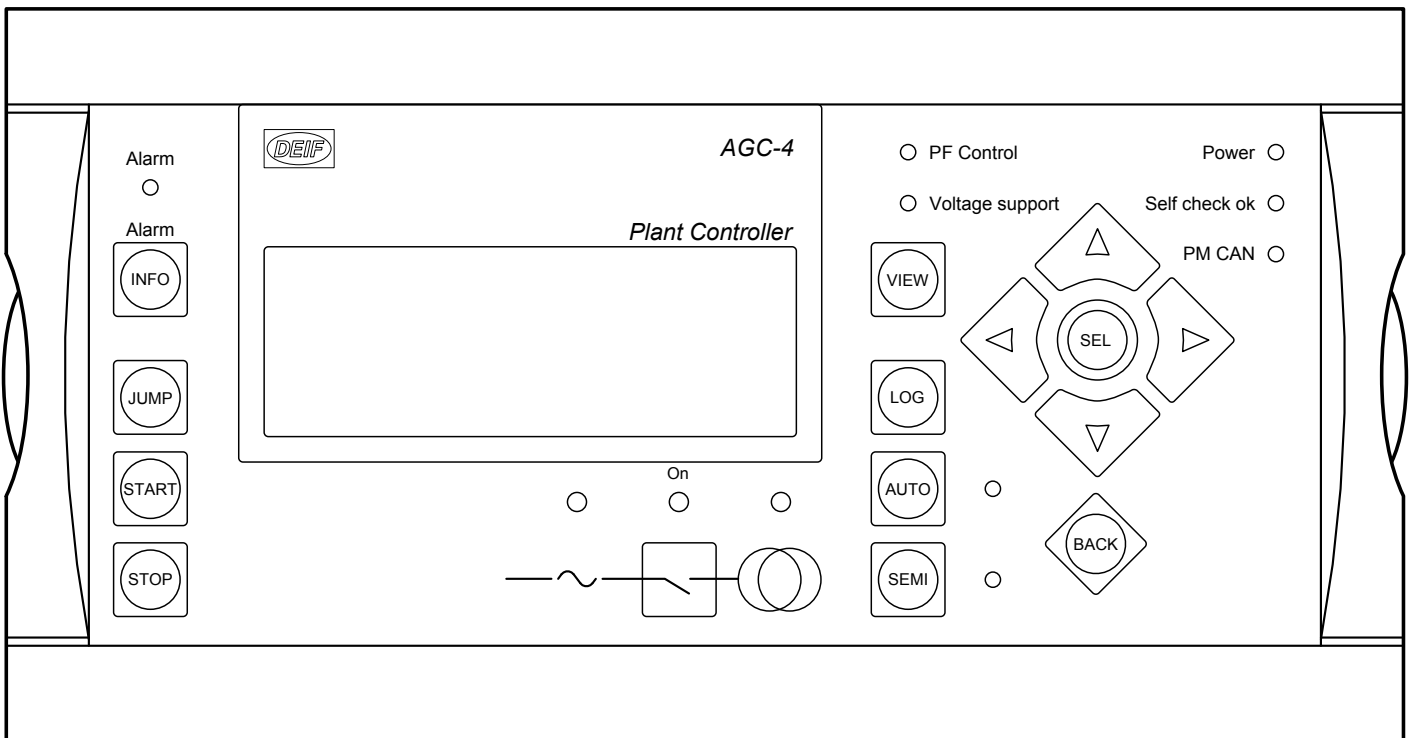

2.2 Button functions

Standard AGC-4 Mk II folio

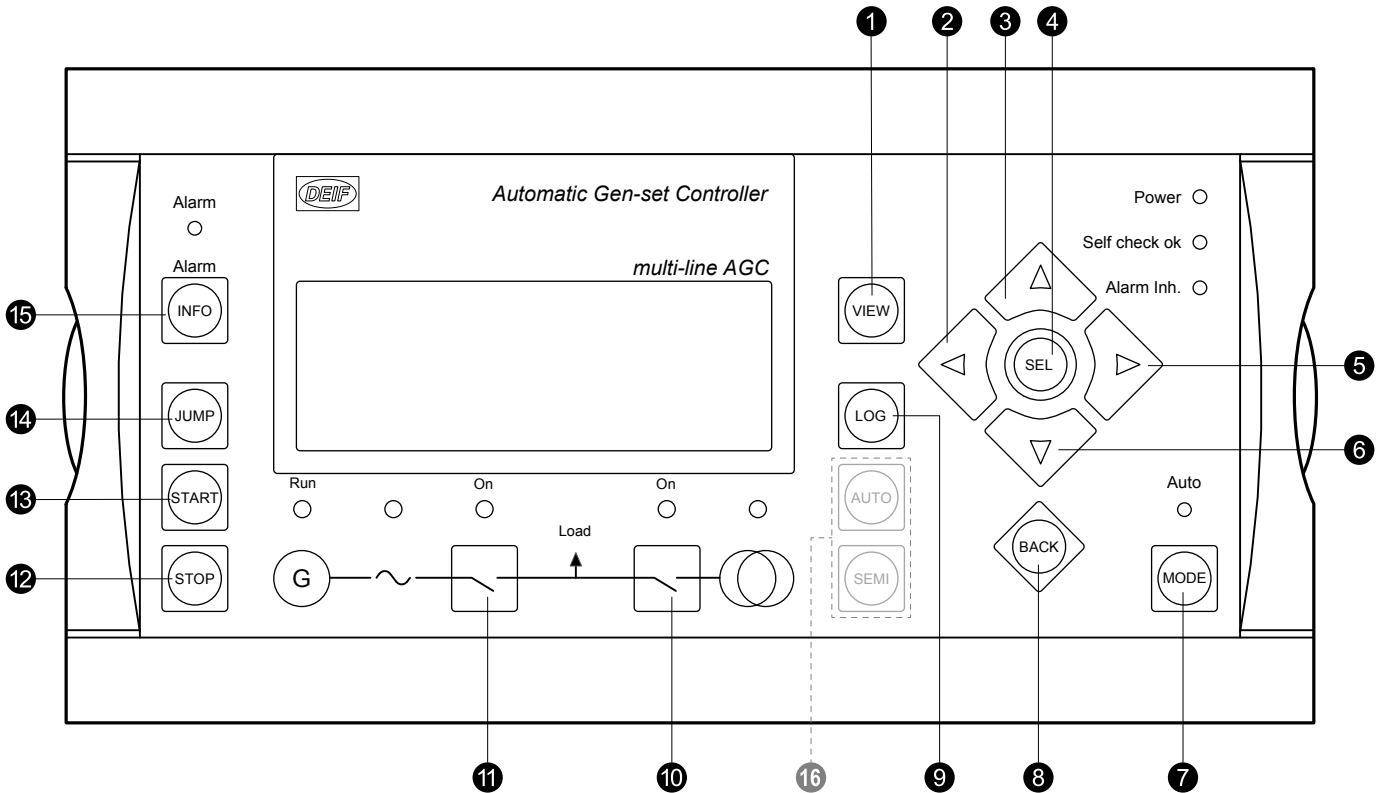

AGC - GER (German) folio

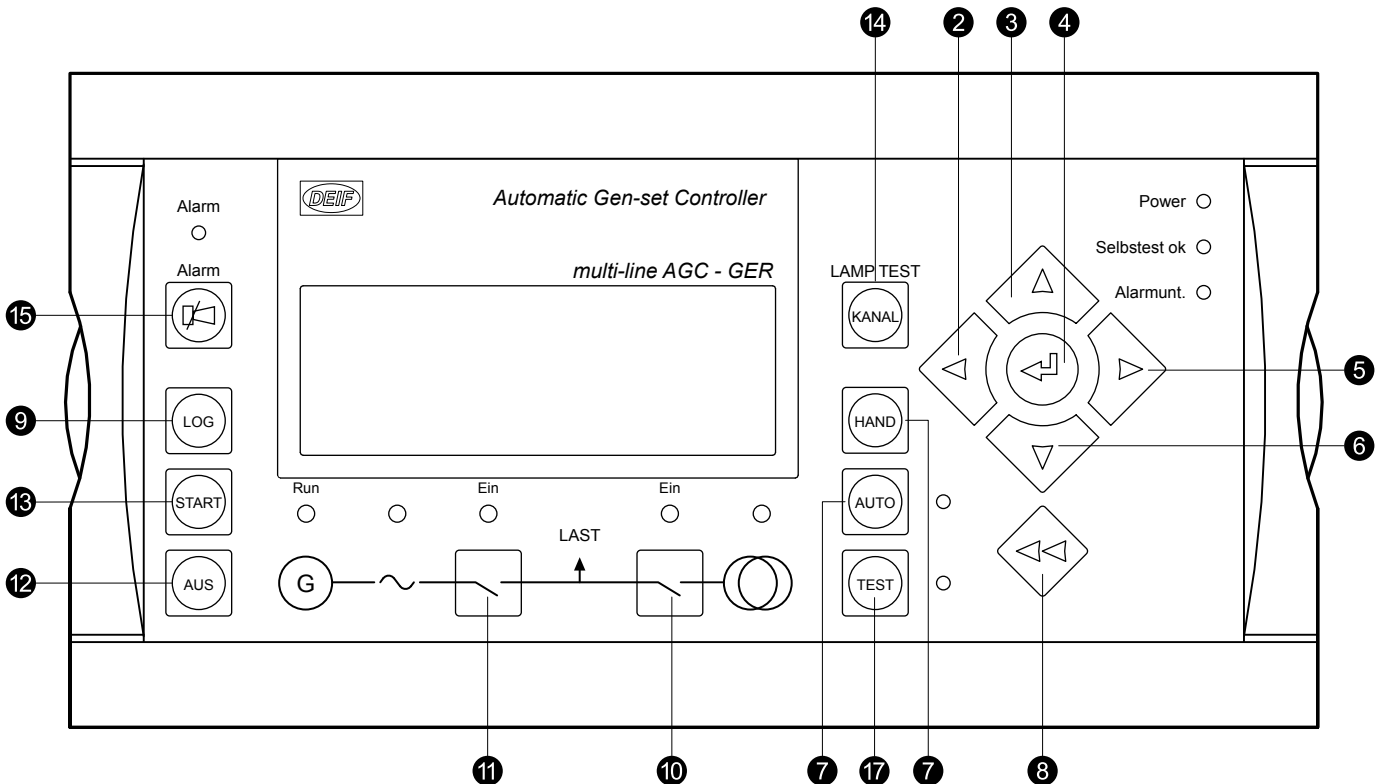



1. Shifts the first line displaying in the setup menus. If more than one DU-2 is connected to the controller, push for 2 seconds to make this DU-2 the master display.
2. Moves the cursor left.
3. Up button: Function depends on context.
 - V1: Scrolls the view lines.

- Setup menu: Displays a different value in the second line.
 - A parameter: Increases the set point.
4. Selects the underscored entry in the fourth line of the display.
 5. Moves the cursor right.
 6. Down button: Function depends on context.
 - V1: Scrolls the view lines.
 - Setup menu: Displays a different value in the second line.
 - A parameter: Decreases the set point.
 7. Changes the menu line (line four) in the display to mode selection.
 - Not present in group and plant controllers.
 8. Jumps one step backwards in the menu (to previous display or to the entry window).
 9. Displays the LOG SETUP window where you can choose between the Event, Alarm and Battery logs. The logs are not deleted when the auxiliary supply is switched off.
 10. Manual activation of close/open breaker sequence if MANUAL mode is selected.
 11. Manual activation of close/open breaker sequence if MANUAL mode is selected.
 12. Stops the genset/plant if MANUAL or NO REGULATION* mode is selected.
 13. Starts the genset/plant if MANUAL or NO REGULATION* mode is selected.
 14. Enables the user to use the menu number to select and display any setting.
 15. Shifts the display three lower lines to show the alarm list. By holding the button, all alarms will be acknowledged.
 16. Group and plant controllers: Select AUTO and MANUAL mode.
 17. German AGC only: Test button.

*Note: NO REGULATION mode is not available in German controllers.

2.3 Modes

If the MODE button is pushed, a selection of possible running modes appears in the fourth display line.

Using the  and  buttons moves the cursor, and the appropriate mode can be selected by pressing the SEL button:

Mode	Description
MANUAL	<ul style="list-style-type: none"> The display buttons (START, STOP, GB ON, GB OFF) are active and can be used by the operator. The regulators are also active, that is, the speed control will bring the generator to nominal speed upon start. When pushing a breaker button for closing, the controller will synchronise (if allowed) the breaker. When the breaker closes, the controls stop.
TEST	<ul style="list-style-type: none"> The controller will start the generator, carry out the test sequence (pre-defined time period) and stop the generator again. Subsequently, the generator will return to AUTO or MANUAL mode. The mains breaker will remain closed, and the generator breaker will remain open. NOTE: The test running can be: Simple test: starting the genset without closing the GB; Load test: parallel to the mains and take load to a pre-defined value; Full test: transfer the load to the genset and open the MB.
AUTO	<ul style="list-style-type: none"> The controller will automatically carry out the control type selected (AMF, fixed power, and so on). The display control buttons (START, STOP, GB ON, GB OFF) are disabled. Mains controller in local (parameter 8021): If the selected running mode is fixed power, mains power export, load takeover or island, timer start/stop (week watch) or binary input, then start/stop can be used.
NO REGULATION*	<ul style="list-style-type: none"> The display buttons (START, STOP) are active and can be used by the operator. The regulators are not active, that is, speed (and voltage) control has to take place using binary inputs for UP and DOWN control. The breakers will be able to open or close at any time. A synchronisation check will always be performed to ensure safe closing of the breakers.
BLOCK	<ul style="list-style-type: none"> The controller will not be able to start the equipment. BLOCK mode can be selected during standstill and the password is needed to exit BLOCK mode. If BLOCK mode is selected while the genset is running, the mode will have no effect until the genset is stopped. To select another mode after BLOCK mode, the password must be entered.

*Note: NO REGULATION mode is not available on the German controller.

To return to the other display functions from MODE selection, press the BACK button.

2.4 LED functions

Standard AGC-4 Mk II folio

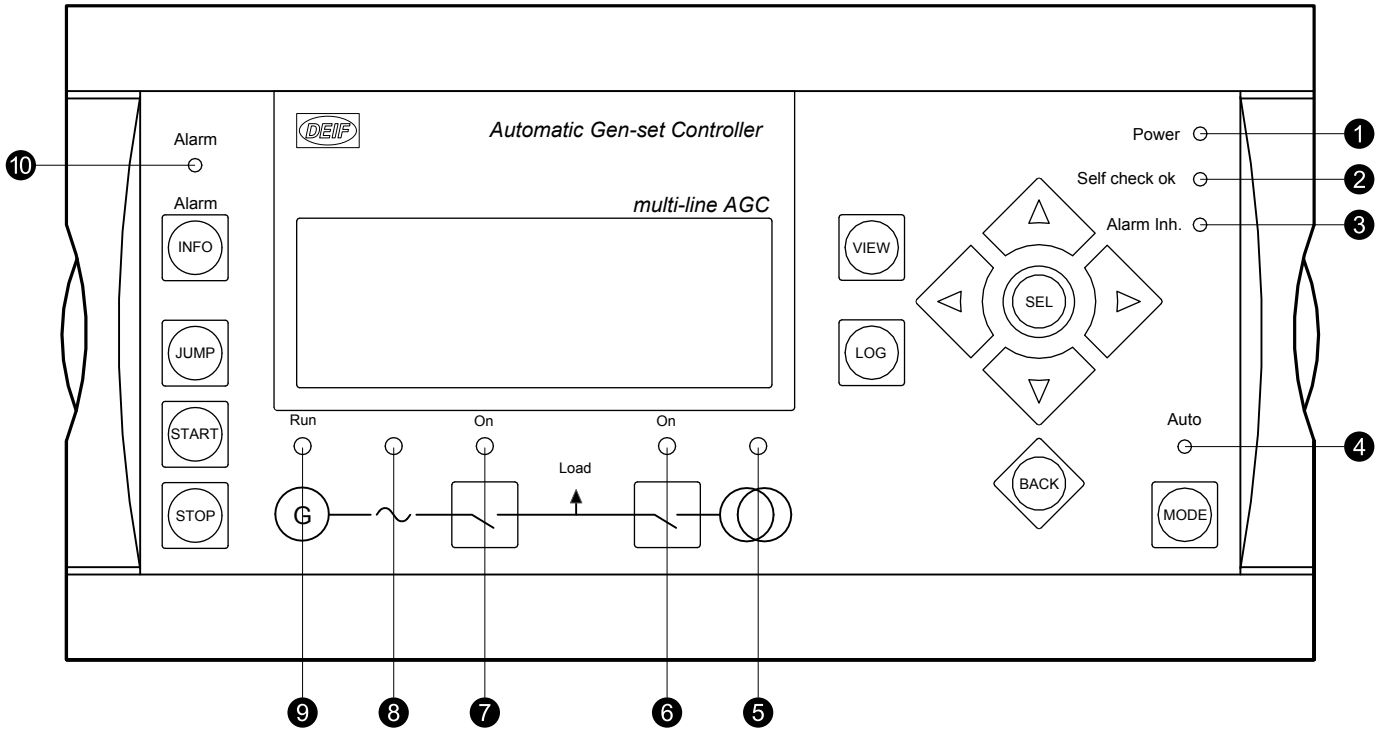

AGC - GER (German) folio

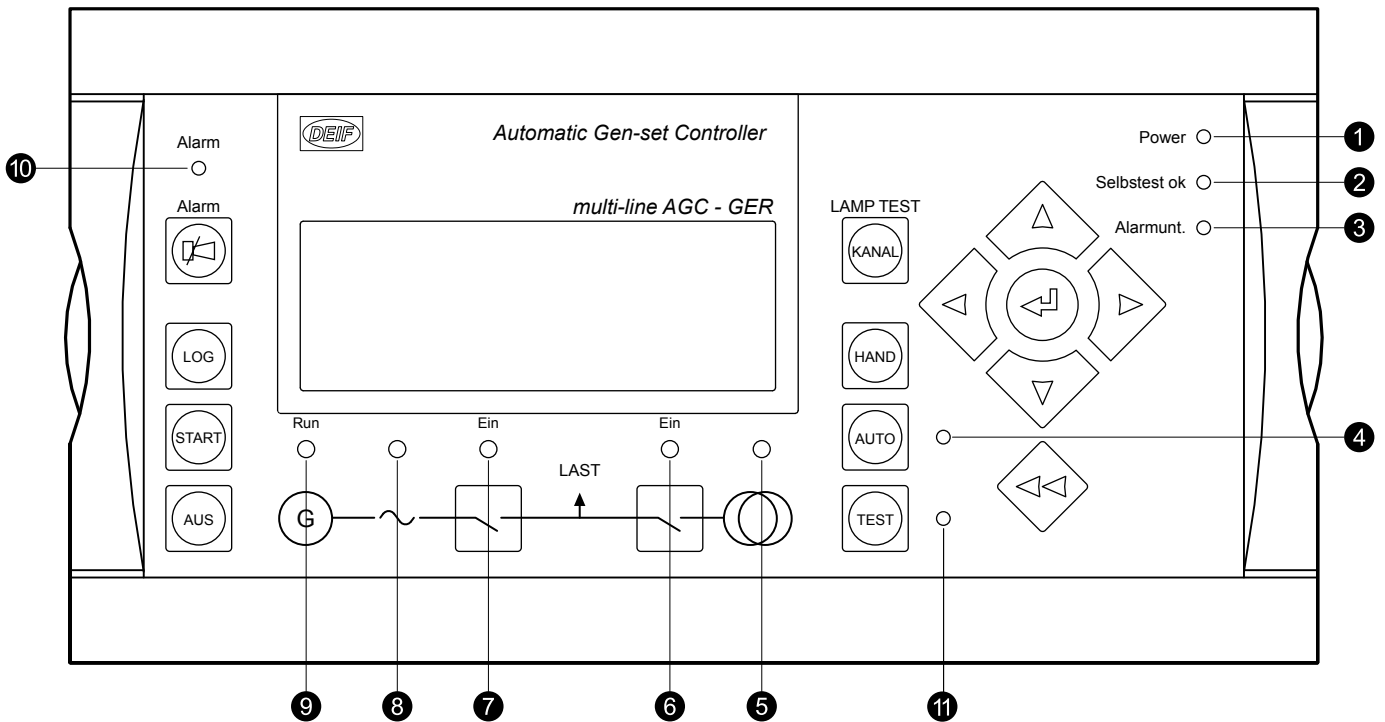

1. LED indicates that the auxiliary supply is switched on.
2. LED indicates that the controller is OK.
3. See *Alarm inhibit* in the **Designer's handbook**.
 - In group and plant controllers, this is the power management CAN bus communication status.
4. LED indicates that auto mode is selected.
 - In group and plant controllers, this is replaced by the status LEDs next to the AUTO and SEMI buttons. The SEMI status LED is lit when the controller is in MANUAL mode.
5. LED is green if the mains is present and OK. LED is red for a measured mains failure. LED is flashing green when the mains returns during the *mains OK delay* time.

6. LED green light indicates that the mains breaker is closed. LED is flashing yellow if the *MB spring loaded* signal from the breaker is missing or the MB load time has not expired.
7. LED green light indicates that the generator breaker is closed. LED yellow light indicates that the generator breaker has received a command to close on a black bus, but the breaker is not yet closed due to interlocking of the GB. LED is flashing yellow if the *enable GB black close* or the *GB spring loaded* signal is missing or the GB load time has not expired.
8. LED green light indicates that the voltage/frequency is present and OK.
9. LED indicates that the generator is running.
10. LED flashing indicates that unacknowledged alarms are present. LED fixed light indicates that ALL alarms are acknowledged, but some are still present.
11. German AGC only: TEST LED.

2.4.1 LED colour schemes

There are two colour schemes for the display LEDs. If LED colour scheme 2 is required, use parameter 6082 (DU-2 only) to select it.

Breaker or bus status	Colour scheme 1 (default)	Colour scheme 2
Breaker closed	Green	Red
Breaker open	White/no color	Green
Mains fail 0-30%	Red	Green
Mains above 30% but not inside "Hz/V OK" window.	Red	Red
Mains inside "Hz/V OK" window	Green	Red
Busbar fail 0-30%	No color	Green
Busbar above 30% but not side "Hz/V OK" window	Red	Red
Busbar inside "Hz/V OK" window	Green	Red
DG fail 0-30%	No color	Green
DG above 30% but not inside "Hz/V OK" window	Red	Red
DG inside "Hz/V OK" window	Green	Red

3. LCD display and menus

3.1 LCD display

The display is a backlit LCD text display. It has four lines with 20 characters in each line. Use parameter 9150 to increase or decrease the brightness.

3.2 Menus

The display includes two menu systems.

- Setup
 - The operator can see the controller's parameters.
 - Changes to the parameter configuration require a password.
- View
 - The operator can see the operating status and values.

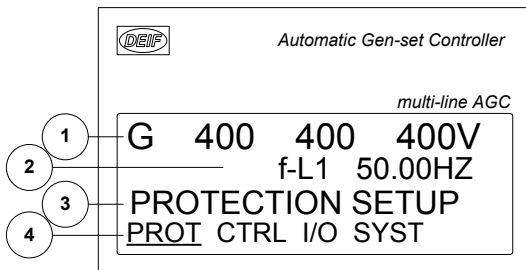

Display line	Use	Description
1	Daily use	Status or operating values.
2	Daily use	Operating values.
	Setup menu	Information for the parameter number.
3	Alarm/log	The latest alarm/event.
	Daily use	Details for the line 4 cursor selection.
4	Setup menu	The selected setting. When changes are made, the minimum and maximum values.
	Daily use	Select setup or view 1, 2 or 3. Press SEL to enter.
	Setup menu	Sub-functions for the parameter, for example, limit.

3.2.1 Entry window

When the controller is powered up, the window shown below appears.

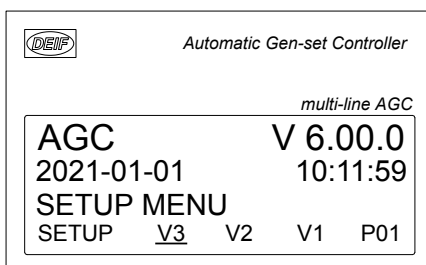

This window is the gateway to the other menus. View V3 can always be reached by pushing the BACK button three times.

For Genset and Group controllers, the priority is shown in the lower right corner of the display. You can use the PC utility software to change the priority.

3.3 Password management

The controller includes three password levels. All levels can be adjusted in the PC software.

Password level	Factory setting	Access		
		Customer	Service	Master
Customer	2000	X		
Service	2001	X	X	
Master	2002	X	X	X

A parameter cannot be entered with a password that is ranking too low. But the settings can be displayed without password entry.

Each parameter can be protected by a specific password level. To do so, the PC utility software must be used. Enter the parameter to be configured and select the correct password level.

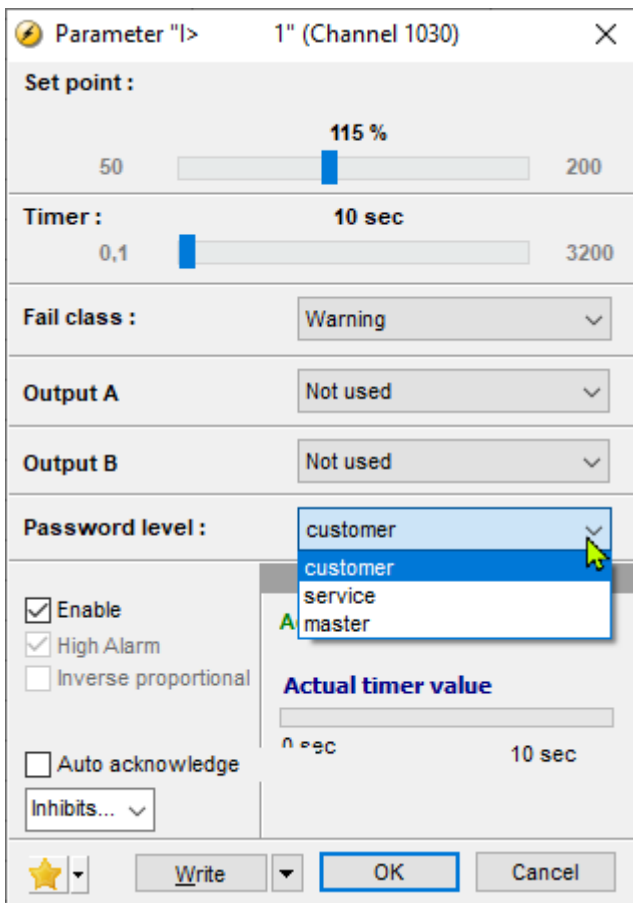

The password level can also be changed from the parameter view in the column "Level". Right-click the field, select "Change access level" and then select the required password level.

alarm	Level	Inhibits	FailClass
	customer	<input type="checkbox"/>	Tri
			Tri
			Wa
	customer	<input type="checkbox"/>	Tri
	service	<input type="checkbox"/>	Tri
	master	<input type="checkbox"/>	Tri

3.3.1 Parameter access

To change parameters, the user must be logged on with the required access level (master, service or customer). If the user is not logged on at the correct access level, it is not possible to change the parameters. In addition, it is not possible to change the password for a higher level than the password entered.

The factory passwords must be changed if the operator is not allowed to change the parameters. The customer password can be changed in jump menu 9116. The service password can be changed in jump menu 9117. The master password can be changed in jump menu 9118.

3.4 Setup

The setup menu system is used to configure the controller. It includes information that is not available in the view menu system. From the entry window, select SETUP in the line 4.

These are the setup sub-menus:

- Protection setup
- Control setup
- I/O setup
- System setup

Setup structure

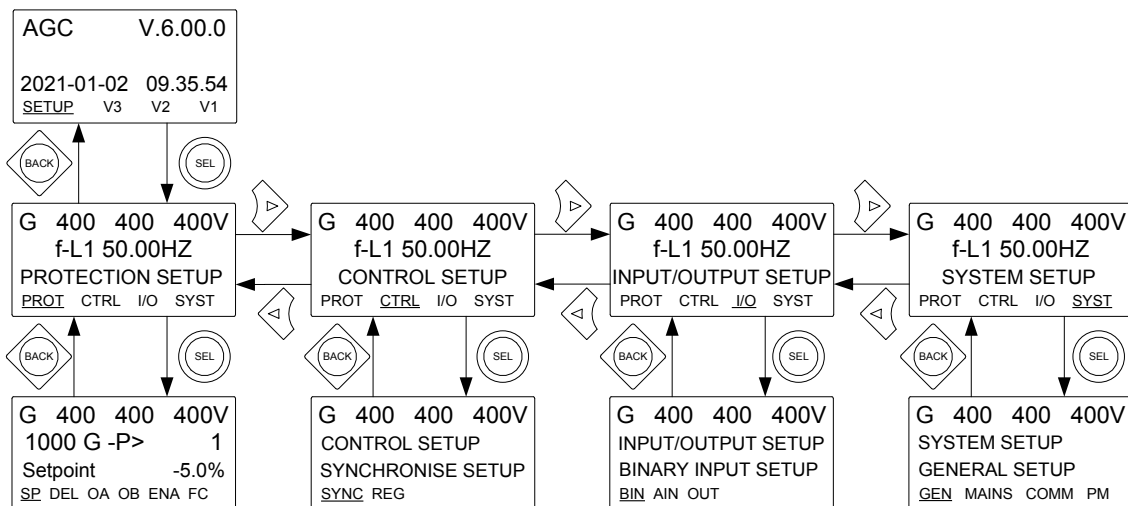

Setup example

This example shows how a reverse power protection set point is changed.

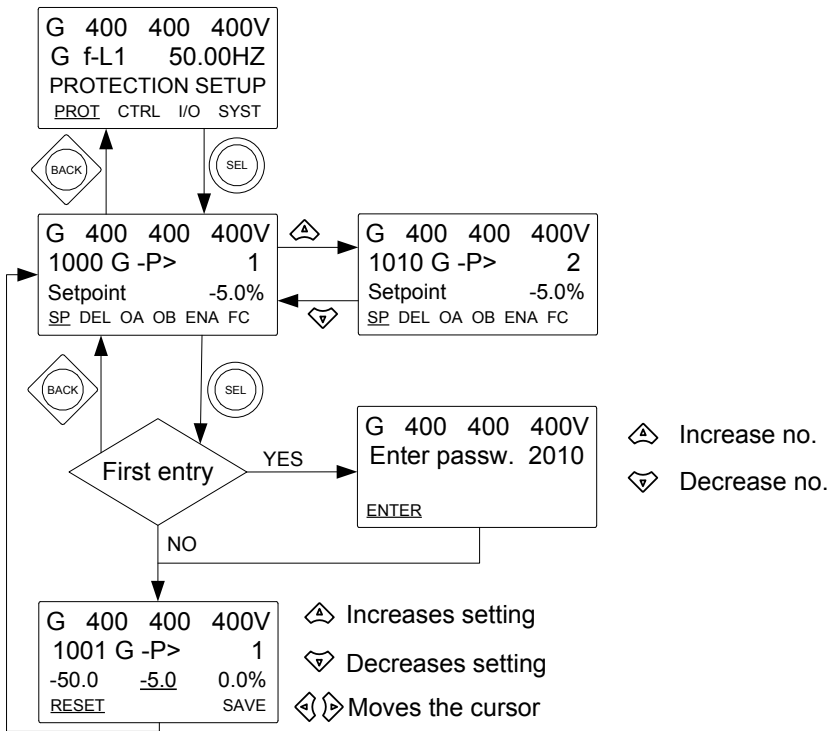

3.5 Views

The view menus (V1, V2 and V3) display a variety of measured values.

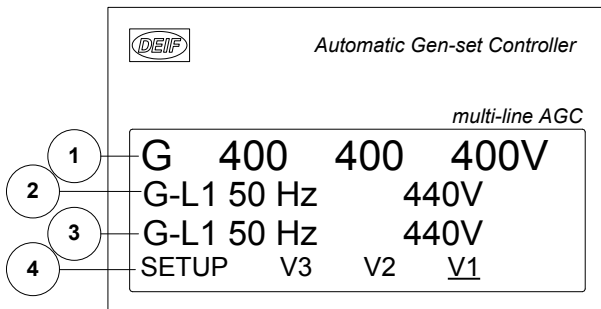

1. Measurements (V1 and V2) or status (V3)
2. Measurements
3. Measurements
4. Selection of setup and view menus

Navigation

The operator can select the view by moving the cursor (line 4) using the and buttons. The cursor is the underscore (V1 in the drawing above).

3.5.1 Configurable views V1 and V2

V1 and V2 consist of 20 windows to display the values selected during configuration. V1 and V2 are identical. Select the window to display using the and buttons.



More information

See the **Designer's handbook** for information about configuration.

3.5.2 Dynamic view V3

The V3 display is dynamic:

- First display line: Status text. This shows the controller running status.
- Second and third display lines: Relevant measured values.
- Fourth display line: Selection line.

NOTE V3 is not configurable. The information shown is determined by the running status.

3.5.3 View menu example

The following is an example of a configured view menu system. In this example, four of the 20 windows in view 1 are shown.

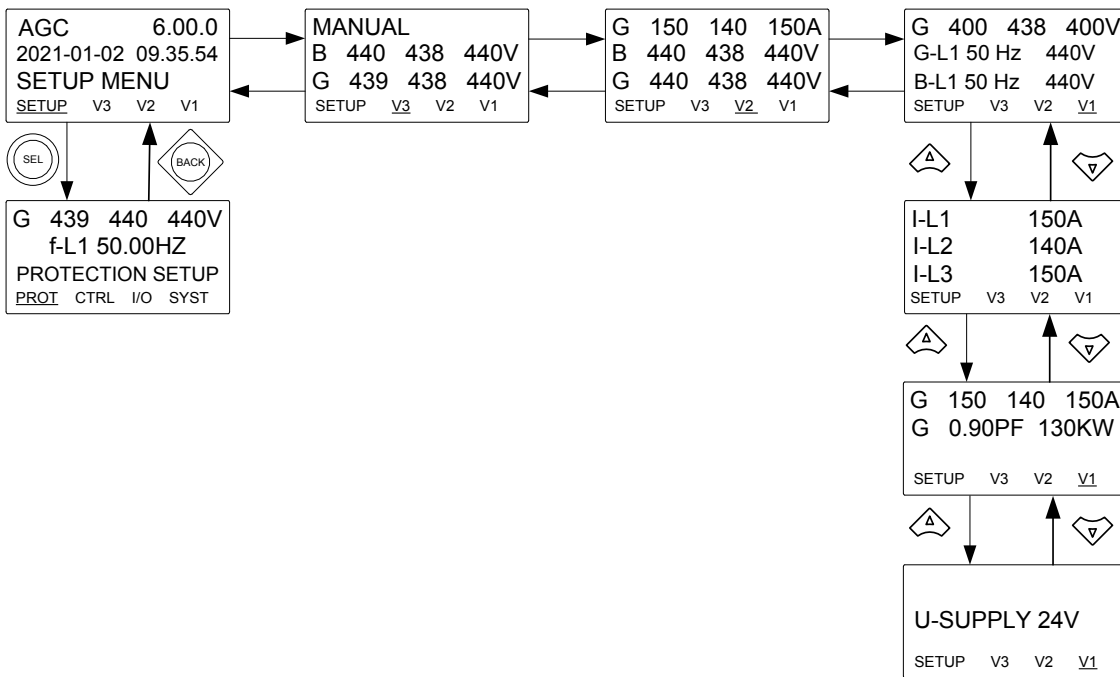

3.6 Status texts

Status text	Description
!DO NOT POWER OFF!	Do not remove the controller power. The controller is busy with a critical operation.
ACCESS LOCK	The configurable input is activated, and the operator presses one of the blocked keys.
ADAPT IN PROGRESS	The AGC is receiving the application that it has just connected to.
AMF ACTIVE	The controller is in auto mode during a mains failure.
AMF AUTO	The mains controller is in auto mode and ready to respond.
AMF MAN	The controller is in manual mode and waiting for operator input.
AMF NO-REG	The controller is in no regulation mode and waiting for operator input.
ANY DG CHANGE PRIO.	A genset priority has changed.
Applying IP config.	The IP settings have been changed, so the controller is updating the configuration (this takes about 30 seconds).
AUTO OPERATION	Power management, BTB controller: The controller is in Auto mode, but not ready for breaker operation (due to an active <i>BTB trip</i> alarm).
AUX TEST ##.#V ####s	The battery test is activated.
AWAITING MODE INFO	The controller is waiting for mode information.
BB A BLOCKING	Due to a problem on busbar A, the BTB controller cannot close the BTB.
BB B BLOCKING	Due to a problem on busbar B, the BTB controller cannot close the BTB.
BB BLOCKED	The busbar is blocked.
BB BLOCKED BY GB##	Power management: GB## has a position failure.
BB BLOCKED BY MB##	Power management: MB## has a position failure.
BB BLOCKED BY TB##	Power management: TB## has a position failure.
BB V/Hz OK IN ####s	The busbar voltage and frequency okay timer is running.
BLACKOUT ENABLE	Genset controller: There is a CAN failure in a power management application.
BLOCKED BY GB ALARM	The action is blocked by a generator breaker alarm.
BLOCKED FOR CLOSING	Power management, BTB controller: Last open BTB in a ring busbar.
BROADCAST ABORTED	Power management: Broadcast terminated.
BROADCAST COMPLETED	Power management: Successful broadcast of an application.
BROADCASTING APPL. #	Power management: Broadcast one of the four applications from one controller to the other AGCs in the power management system, through the CAN line.
BTB ## DIVIDING SEC.	Power management, Genset controller: BTB ## is dividing two sections in an island application.
BTB TRIP EXTERNALLY	Some external equipment has tripped the breaker. An external trip is logged in the event log.
BTB## BLOCKED	Power management: # is replaced by A or B depending on where the problem is located.
BLOCK	Block mode is activated.
BTB RACKED OUT	The <i>Breaker racked out</i> digital input is activated. Position failure and external trip alarms from the racked out breaker will not interfere with the rest of the system.
#### Busbar blocked	Power management: Power sources cannot connect because breaker feedback is missing.
Busbar V/Hz OK	The busbar voltage and frequency are okay.
CBE config relay/DVC	CBE is enabled in parameter 2254, but no AVR relay or DVC 310/D510C/DVC 550 is configured. The CBE sequence will not be executed.
CHANGE PRIO NOT OK	The controller cannot change the priority.

Status text	Description
CHANGING PRIORITY	A manual priority change is being applied.
CHECKING CAN PMS	In <i>Easy connect</i> , the controller is checking the CAN line for another controller.
COMPENSATION FREQ.	Compensation is active. The frequency is not at the nominal setting
COOLING DOWN	Cooling down period is activated and indefinite (the cooling down timer is set to 0.0 s).
COOLING DOWN ###s	Cooling down period is activated.
DELOAD	The controller is decreasing the load of the genset in order to open the breaker.
DELOADING BTB ##	Genset controllers are load sharing asymmetrically to de-load BTB ##.
DELOADING MB ##	Genset controllers are increasing their load to de-load MB ##.
DELOADING TB ##	Genset controllers are decreasing their load to de-load TB ##.
DERATED TO #####kW	Displays the ramp down set point.
DG BLOCKED FOR START	The generator has stopped and has active alarm(s).
DIVIDING SEC IN ###s	The BTB will open in ###s.
DIVIDING SECTION	Power management: A BTB controller is dividing two sections in an island application.
DRY ALTERNATOR AUTO	The mains controller is in auto mode and ready to respond.
DRY ALTERNATOR MAN	The controller is in manual mode and waiting for operator input.
DRY ALTERNATOR NOREG	The controller is in no regulation mode and waiting for operator input.
DRYING ALTERNATOR	The controller is in auto mode and drying the alternator.
EASY CONNECT ERROR	There was an error during <i>Easy connect</i> .
ENTER BLACK BUSBAR	The busbar is black.
EXTENDED STOP TIME	The engine is running for the extended stop time.
EXTERNAL START ORDER	A planned AMF sequence is activated (without a mains failure).
EXT. MB OPEN FAILURE	The external mains breaker failed to open.
EXT. STOP TIME ###s	The engine is running for the extended stop time, and will stop in ###s.
FIXED POWER ACTIVE	The controller is in auto mode and supplying fixed power.
FIXED POWER AUTO	The mains controller is in auto mode and ready to respond.
FIXED POWER MAN	The controller is in manual mode and waiting for operator input.
FIXED POWER NO-REG	The controller is in no regulation mode and waiting for operator input.
FULL TEST	Test mode is activated.
FULL TEST ###.#min	Test mode activated and test timer counting down.
GB AND MB RACKED OUT	The <i>Breaker racked out</i> digital input is activated. Position failure and external trip alarms from the racked out breakers will not interfere with the rest of the system.
GB ON BLOCKED	The generator is running, the GB is open and there is an active <i>Trip GB</i> alarm.
GB RACKED OUT	The <i>Breaker racked out</i> digital input is activated. Position failure and external trip alarms from the racked out breaker will not interfere with the rest of the system.
GB TRIP EXTERNALLY	Some external equipment (not the controller) has tripped the breaker. An external trip is logged in the event log.
GENSET STOPPING	Cooling down has finished.
Hz/V OK IN ###s	The voltage and frequency on the genset is OK. When the timer expires the generator breaker can be closed.
ID 1-16 SUPPORT ONLY	The application can only support controller IDs 1 to 16.
IDLE RUN	The <i>Idle run</i> function is active. The genset will not stop until the timer has expired.

Status text	Description
IDLE RUN ###.#min	The timer in the <i>Idle run</i> function is active.
ISLAND ACTIVE	The controller is in auto mode and supplying power while not connected to a mains supply.
ISLAND AUTO	The mains controller is in auto mode and ready to respond.
ISLAND MAN	The controller is in manual mode and waiting for operator input.
ISLAND NO-REG	The controller is in no regulation mode and waiting for operator input.
LANG. DOWNLOAD ERROR	The controller was downloading a language, and there was an error.
LOAD TAKEOVER AUTO	The mains controller is in auto mode and ready to respond.
LOAD TAKEOVER MAN	The controller is in manual mode and waiting for operator input.
LOAD TAKEOVER NOREG	The controller is in no regulation mode and waiting for operator input.
LOAD TEST	Test mode is activated.
LOAD TEST ###.#min	Test mode activated and test timer counting down.
LOW SPEED OFF ###.#m	The engine low speed off timer will expire in ###.# minutes.
LOW SPEED ON ###.#m	The engine low speed on timer will expire in ###.# minutes.
LTO ACTIVE	The controller is in auto mode and taking over the load.
MAINS FAILURE	Mains failure and mains failure timer expired.
MAINS FAILURE IN ###s	The frequency or voltage measurement is outside the limits. The timer shown is the Mains failure delay.
MAINS f OK DEL #####s	Mains frequency is OK after a mains failure. The timer shown is the Mains OK delay.
MAINS OK	The mains voltage and frequency are okay.
MAINS OK INPUT HIGH	The mains is okay (digital input is high).
MAINS OK INPUT LOW	The mains is not okay (digital input is low).
MAINS P EXPORT AUTO	The mains controller is in auto mode and ready to respond.
MAINS P EXPORT MAN	The controller is in manual mode and waiting for operator input.
MAINS P EXPORT NOREG	The controller is in no regulation mode and waiting for operator input.
MAINS U OK DEL #####s	The mains voltage is OK after a mains failure. The timer shown is the Mains OK delay.
MANUAL OPERATION	Power management, BTB controller: BTB controller in manual mode.
MB INHIBIT BY ESS##	The mains breaker is inhibited by ESS##.
MB RACKED OUT	The <i>Breaker racked out</i> digital input is activated. Position failure and external trip alarms from the racked out breaker will not interfere with the rest of the system.
MB TRIP EXTERNALLY	Some external equipment (not the controller) has tripped the breaker. An external trip is logged in the event log.
MOUNT CAN CONNECTOR	Connect the power management CAN line.
MPE ACTIVE	The controller is in auto mode and exporting power to the mains.
PEAK SHAVING ACTIVE	The controller is in auto mode and doing peak shaving.
PEAK SHAVING AUTO	The mains controller is in auto mode and ready to respond.
PEAK SHAVING MAN	The controller is in manual mode and waiting for operator input.
PEAK SHAVING NO-REG	The controller is in no regulation mode and waiting for operator input.
POWER UP	The controller application is starting.
PREPARING ENGINE IF	Preparing the engine interface. The EIC values are not yet available.

Status text	Description
PREPARING ETHERNET	Preparing the Ethernet connection. Communication with USW or over Modbus TCP/IP is not yet possible.
PROGRAM. APPL. DATA	Downloading application data to the controller.
PROGRAMMING CIO	Downloading the CIO configuration to the controller.
PROGRAMMING LANGUAGE	Downloading the language file, using the PC utility software.
PROGRAMMING M-LOGIC	Downloading M-Logic to the controller.
QUICK SETUP ERROR	Quick setup of the application failed.
RAMP FREEZED	The power ramp is paused.
RAMP TO #####kW	The power ramp is ramping in steps. The next step that will be reached after the timer has expired is displayed.
RECEIVE COMPLETED	Power management: Application received successfully.
RECEIVE ERROR	Power management: Application is not received correctly.
RECEIVING APPL. #	Power management: The AGC is receiving an application.
READY AMF AUTO	The genset controller is in auto mode and the genset is stopped.
READY AUTO OPERATION	BTB controller in Auto and ready for breaker operation (no active <i>BTB trip</i> alarm).
READY DRY ALT. AUTO	The genset controller is in auto mode and the genset is stopped.
READY FIXED P AUTO	The genset controller is in auto mode and the genset is stopped.
READY ISLAND AUTO	The genset controller is in auto mode and the genset is stopped.
READY LTO AUTO	The genset controller is in auto mode and the genset is stopped.
READY MPE AUTO	The genset controller is in auto mode and the genset is stopped.
READY PEAK SHAV AUTO	The genset controller is in auto mode and the genset is stopped.
READY TO BE ADDED	For <i>Easy connect</i> , the controller is ready to be added.
READY VENTIL. AUTO	The genset controller is in auto mode and the genset is stopped.
RECEIVE COMPLETED	The controller has finished receiving the data.
RECEIVE ERROR	An error occurred while the controller was receiving data.
RECEIVING APPL. #	The controller is receiving application # from the utility software.
RECEIVING DAVR SETUP	The controller is receiving the DAVR setup from the utility software.
REDUNDANT CONTROLLER	This controller is redundant. Use the other controller for operator actions.
REMOVE CAN CONNECTOR	Remove the power management CAN lines.
REM. DG## CAN PMS?	For <i>Easy connect</i> , confirm removal of genset ##.
REM. ESS## CAN PMS?	For <i>Easy connect</i> , confirm removal of battery ##.
REM. PV## CAN PMS?	For <i>Easy connect</i> , confirm removal of solar ##.
REQUEST BTB in ###s	A BTB close will be requested in ###s.
RUN COIL ON	The engine run coil relay is activated.
SECONDARY DISPLAY	The display is the secondary display.
SELECT GENSET MODE	Power management is deactivated and no other genset mode is selected.
SELECT PLANT MODE	For extended power management, you can select the plant mode.
SENDING DAVR SETUP	The AGC is sending settings to the DVC.

Status text	Description
SETUP COMPLETED	Successful update of the application in all AGC controllers.
SETUP IN PROGRESS	The new AGC is being added to the existing application.
SETUP STAND ALONE?	For <i>Easy connect</i> , confirm setting up a stand alone application.
SHUTDOWN OVERRIDE	The configurable input is active.
SIMPLE TEST	Test mode is activated.
SIMPLE TEST ###.#min	Test mode is activated and the test timer is counting down.
START DG(s) IN ###s	The start genset set point is exceeded.
START NEW PLANT?	Confirm whether to start the plant.
START PREPARE	The start prepare relay is activated.
START RELAY OFF	The start relay is deactivated during the start sequence.
START RELAY ON	The start relay is activated.
STOP DG(s) IN ###s	The stop genset set point is exceeded.
SYNCHRONISING BTB ##	Genset controller: BTB ## is synchronising.
SYNCHRONISING MB ##	Genset controller: MB ## is synchronising.
SYNCHRONISING TB ##	Genset controller: TB ## is synchronising.
TB AND MB RACKED OUT	The <i>Breaker racked out</i> digital input is activated. Position failure and external trip alarms from the racked out breakers will not interfere with the rest of the system.
TB BLOCKED BY BB	The tie breaker cannot close because of a problem on the busbar.
TB BLOCKED BY MB	The tie breaker cannot close because of a mains breaker problem.
TB INHIBIT BY ESS##	The tie breaker is inhibited by ESS##.
TB RACKED OUT	The <i>Breaker racked out</i> digital input is activated. Position failure and external trip alarms from the racked out breaker will not interfere with the rest of the system.
TB TRIP EXTERNALLY	Some external equipment has tripped the breaker. An external trip is logged in the event log.
TEST MODE	Test mode is activated.
-----→ 00 TOO FAST	Generator running too fast during synchronising.
TOO SLOW 00←-----	Generator running too slow during synchronising.
UNEXPECTED GB ON BB	Another generator breaker is closed on to the busbar (due to a GB position failure) while no voltage is present on the busbar. This indicates that other breakers cannot close to the busbar because of position failure on one or more GBs.
UNEXPECTED TB ON BB	A TB that is not expected to be closed is closed.
UNIT STANDBY	Power management: If a redundant mains controller is present, this message is shown on the redundant controller.
VENTILATION ACTIVE	The controller is in auto mode and ventilating.
VENTILATION AUTO	The mains controller is in auto mode and ready to respond.
VENTILATION MAN	The controller is in manual mode and waiting for operator input.
VENTILATION NO-REG	The controller is in no regulation mode and waiting for operator input.
VERIFYING SC REMOVED	The GB is closed for the first time after alternator drying.
VOLTAGE/FREQUENCY OK	The voltage and frequency are okay, and the timer has expired.
WARM UP RAMP	Warm up ramp is active. The available power is limited until the pre-defined temperature is reached, or when the input that activated warm up ramp is deactivated.

3.7 Alarm handling

When an alarm occurs, the display unit automatically goes to the alarm list to display the alarm.

If you do not want to view the alarms, use the BACK button to exit the alarm list.

If you decide to enter the alarm list later, use the INFO button to jump directly to the alarm list.

The alarm list contains active alarms (that is, the alarm condition is still present), both acknowledged and unacknowledged. Once an alarm is acknowledged and the condition has disappeared, the alarm is no longer displayed in the alarm list.

This means that if there are no alarms, the alarm list is empty.



DANGER!





Automatic genset start after an alarm is cleared

An alarm can block a genset start. When the alarm condition is no longer present and the alarm is acknowledged, the alarm no longer blocks the genset start. If the start conditions are still active and the controller is in AUTO, the controller automatically starts the genset and closes the breaker.

```
G    0    0    0V
3490 Emergency STOP
UN-ACK | 2 Alarm(s)
ACK   FIRST LAST
```

This display example shows an unacknowledged alarm. The display can show only one alarm at a time.

To see the other alarms, use the  and  buttons to scroll in the display.

To acknowledge an alarm, place the cursor (underscore) under "ACK" and then press SEL.

To jump to the first (oldest) or the last (most recent) alarm, place the cursor under the selection (FIRST or LAST) and press SEL.

Understanding alarm numbers

Many alarms start with a number (for example, **3490**). This is the parameter group for the alarm. See the **Parameter list** for more information.

3.7.1 Self-check errors

When a controller is connected to a DVC 550 or D550 digital AVR, a *Self-check error* alarm might be activated in the controller. For all of these alarms, the alarm action is BLOCK.





If a *Self-check error* alarm is activated in the controller, contact [DEIF support](#). We will help you to fix the problem and clear the alarm.



3.8 Log list

There are three log lists:

1. **Event log** - up to 500 events. For example, closing of breaker, and starting of engine.
2. **Alarm log** - up to 500 historical alarms. For example, over-current, and high cooling water temperature.
3. **Battery log** - up to 52 historical battery tests. For example, test OK, and test failed.

To enter the log list:

1. Press LOG.
2. Use the  and  buttons to move to the list you want to view, then press the SEL button.
3. To scroll up and down in the list, use the  and  buttons.

To go the first (oldest) log or the last (most recent) log: Use the  and  buttons to move the cursor under the selection, then press the SEL button.

4. Maintenance and disposal

4.1 Maintenance

The AGC-4 Mk II does not require maintenance. If the controller is damaged, you can send it to DEIF for replacement of the damaged parts.

4.2 Disposal of waste electrical and electronic equipment

WEEE symbol



All products that are marked with the crossed-out wheeled bin (the WEEE symbol) are electrical and electronic equipment (EEE). EEE contains materials, components and substances that can be dangerous and harmful to people's health and to the environment. Waste electrical and electronic equipment (WEEE) must therefore be disposed of properly. In the EU, the disposal of WEEE is governed by the WEEE directive issued by the European Parliament. DEIF complies with this directive.

You must not dispose of WEEE as unsorted municipal waste. Instead, WEEE must be collected separately, to minimise the load on the environment, and to improve the opportunities to recycle, reuse and/or recover the WEEE. In the EU, local governments are responsible for facilities to receive WEEE. If you need more information on how to dispose of DEIF WEEE, please contact DEIF.