

AGC 150, ASC 150

Installation instructions



1. Introduction

1.1 About the installation instructions	3
1.1.1 Software version.....	4
1.2 Warnings and safety	4
1.3 Legal information	5

2. Product description

2.1 Controller types	7
-----------------------------------	----------

3. Mounting

3.1 Dimensions and weight	8
3.2 Tools and materials	8
3.3 Mounting instructions	9

4. Hardware

4.1 Rear side connections	10
--	-----------

5. Wiring

5.1 Wiring overview	14
5.1.1 Typical wiring for generator controller.....	14
5.1.2 Typical wiring for mains controller.....	15
5.1.3 Typical wiring for BTB controller.....	16
5.1.4 Typical wiring for stand-alone controller.....	17
5.1.5 Typical wiring for marine generator stand-alone controller.....	18
5.1.6 Typical wiring for hybrid genset controller.....	20
5.1.7 Typical wiring for engine drive controller.....	21
5.1.8 Typical wiring for storage controller.....	22
5.1.9 Typical wiring for solar controller.....	23
5.1.10 Typical wiring for ATS controller.....	24
5.1.11 Typical wiring for PMS lite controller.....	27
5.1.12 Wiring guidelines - best practice for grounding.....	28
5.2 AC connections	29
5.2.1 I4 current.....	31
5.2.2 Current transformer ground.....	32
5.2.3 Voltage measurement fuses.....	32
5.3 DC connections	33
5.3.1 Digital inputs.....	33
5.3.2 Digital outputs.....	33
5.3.3 Breaker wiring.....	34
5.3.4 Power supply and start.....	35
5.3.5 Analogue inputs.....	35
5.4 Communication	37
5.4.1 CAN bus and RS-485 cable recommendation.....	37
5.4.2 CAN bus power management system, CANshare, and PMS lite.....	38
5.4.3 Third party digital load sharing.....	38
5.4.4 CAN bus engine communication.....	39
5.4.5 Modbus RS-485 (AGC/ASC is the server).....	39
5.4.6 Modbus RS-485 (ASC is the client).....	41

1. Introduction

1.1 About the installation instructions

General purpose

These are the Installation instructions for DEIF's AGC 150 and ASC 150. The Installation instructions provide information for the correct installation of the controller, with primary focus on the physical installation of the equipment.



CAUTION



Read the instructions

Read these instructions before installation of the controller, to avoid personal injury and damage to the equipment.

Intended users of the Installation instructions

The Installation instructions are primarily intended for the people, who mount and wire up the controller. Designers may find it useful to refer to the Installation instructions, when developing the system's wiring diagrams, and operators may find it useful to refer to the Installation instructions while troubleshooting.

List of technical documentation

Document	Contents
Product sheet	<ul style="list-style-type: none">• Short description• Controller applications• Main features and functions• Technical data• Protections• Dimensions
Data sheet	<ul style="list-style-type: none">• General description• Functions and features• Controller applications• Controller types and variants• Protections• Inputs and outputs• Technical specifications
Designer's handbook	<ul style="list-style-type: none">• Principles• General controller sequences, functions and protections• Protections and alarms• AC configuration and nominal settings• Breaker and synchronisation• Regulation• Hardware characteristics• Communication
Installation instructions	<ul style="list-style-type: none">• Tools and materials• Mounting• Minimum wiring for the controller• Wiring information and examples

Document	Contents
Operator's manual	<ul style="list-style-type: none"> • Controller equipment (buttons and LEDs) • Operating the system • Alarms and log
Modbus tables	<ul style="list-style-type: none"> • Modbus address list <ul style="list-style-type: none"> ◦ PLC addresses ◦ Corresponding controller functions • Descriptions for function codes, function groups
Drawings	<ul style="list-style-type: none"> • 2D CAD drawing, 2D PDF • 3D STEP-file, 3D PDF • EPLAN

1.1.1 Software version

This document is based on the AGC 150 software version 1.20.

1.2 Warnings and safety

Safety during installation and operation

When you install and operate the equipment, you may have to work with dangerous currents and voltages. The installation must only be carried out by authorised personnel who understand the risks involved in working with electrical equipment.



DANGER!



Hazardous live currents and voltages

Do not touch any terminals, especially the AC measurement inputs or any relay terminals, as this could lead to injury or death.

Current transformer danger



DANGER!



Electrical shock and arc flash

Risk of burns and electrical shock from high voltage.

Short all current transformer secondaries before breaking any current transformer connections to the controller.

Disable the breakers



DANGER!



Disable the breakers

Unintended breaker closing can cause deadly and/or dangerous situations.

Disconnect or disable the breakers BEFORE you connect the controller power supply. Do not enable the breakers until AFTER the wiring and controller operation are thoroughly tested.

Disable the engine start



DANGER!

Unintended engine starts



Unintended engine starts can cause deadly and/or dangerous situations.

Disconnect, disable or block the engine start (the crank and the run coil) **BEFORE** you connect the controller power supply. Do not enable the engine start until **AFTER** the wiring and controller operation are thoroughly tested.

UL/cUL Listed

The acceptability of the installation is determined as part of the final assembly.

If field-wired in the end application, you must use a physical barrier between the low voltage and higher voltage wiring connections to make sure that the circuits are separated.

Factory settings

The controller is delivered pre-programmed from the factory with a set of default settings. These settings are based on typical values and may not be correct for your system. You must therefore check all parameters and settings before using the controller.

Electrostatic discharge

Electrostatic discharge can damage the controller terminals. You must protect the terminals from electrostatic discharge during the installation. When the controller is installed and connected, these precautions are no longer necessary.

Data security

To minimise the risk of data security breaches:

- As far as possible, avoid exposing controllers and controller networks to public networks and the Internet.
- Use additional security layers like a VPN for remote access, and install firewall mechanisms.
- Restrict access to authorised persons.

1.3 Legal information

Third party equipment

DEIF takes no responsibility for the installation or operation of any third party equipment, including the **genset**. Contact the **genset company** if you have any doubt about how to install or operate the genset.

Warranty

NOTICE



Warranty

The controller is not to be opened by unauthorised personnel. If opened anyway, the warranty will be lost.

Disclaimer

DEIF A/S reserves the right to change any of the contents of this document without prior notice.

The English version of this document always contains the most recent and up-to-date information about the product. DEIF does not take responsibility for the accuracy of translations, and translations might not be updated at the same time as the English document. If there is a discrepancy, the English version prevails.

Copyright

© Copyright DEIF A/S. All rights reserved.

2. Product description

2.1 Controller types

Parameter	Setting	Controller type	Minimum software
9101	Genset unit	Generator controller	Core
	Genset unit	Non-sync stand-alone generator controller	Stand-alone
	Mains unit	Mains controller	Core
	BTB unit	BTB controller	Core
	Genset HYBRID unit	Hybrid Genset-Solar controller	Core
	ENGINE DRIVE unit	Engine drive controller	Stand-alone
	Remote unit	Remote display	None
	ENGINE DRIVE MARINE unit	Engine drive controller for marine use	Stand-alone
	Genset MARINE unit	Non-sync stand-alone generator controller for marine use	Stand-alone
	ASC 150 Storage*	Battery storage controller	Extended + Sustainability
	ASC 150 Solar*	Solar controller	Extended + Sustainability
	ATS unit	Automatic transfer switch (open transition)	Stand-alone
	ATS unit	Automatic transfer switch (closed transition)	Core
	Genset PMS LITE	PMS lite controller	Core

Software packages and controller types

The controller software package determines which functions the controller can use.

- **Stand-alone**
 - You can change the controller type to any other controller that uses Stand-alone software.
 - Stand-alone software only supports non-synchronisation applications.
- **Core**
 - Core software supports synchronisation applications.
- **Extended**
 - You can change the controller type to any other controller type*.
 - * To change to a storage or solar controller, the controller must also have the sustainability option (S10).
- **Premium**
 - You can change the controller type to any other controller type*.
 - * To change to a storage or solar controller, the controller must also have the sustainability option (S10).
 - All functions are supported.

You can select the controller type under `Basic settings > Controller settings > Type`.

3. Mounting

3.1 Dimensions and weight

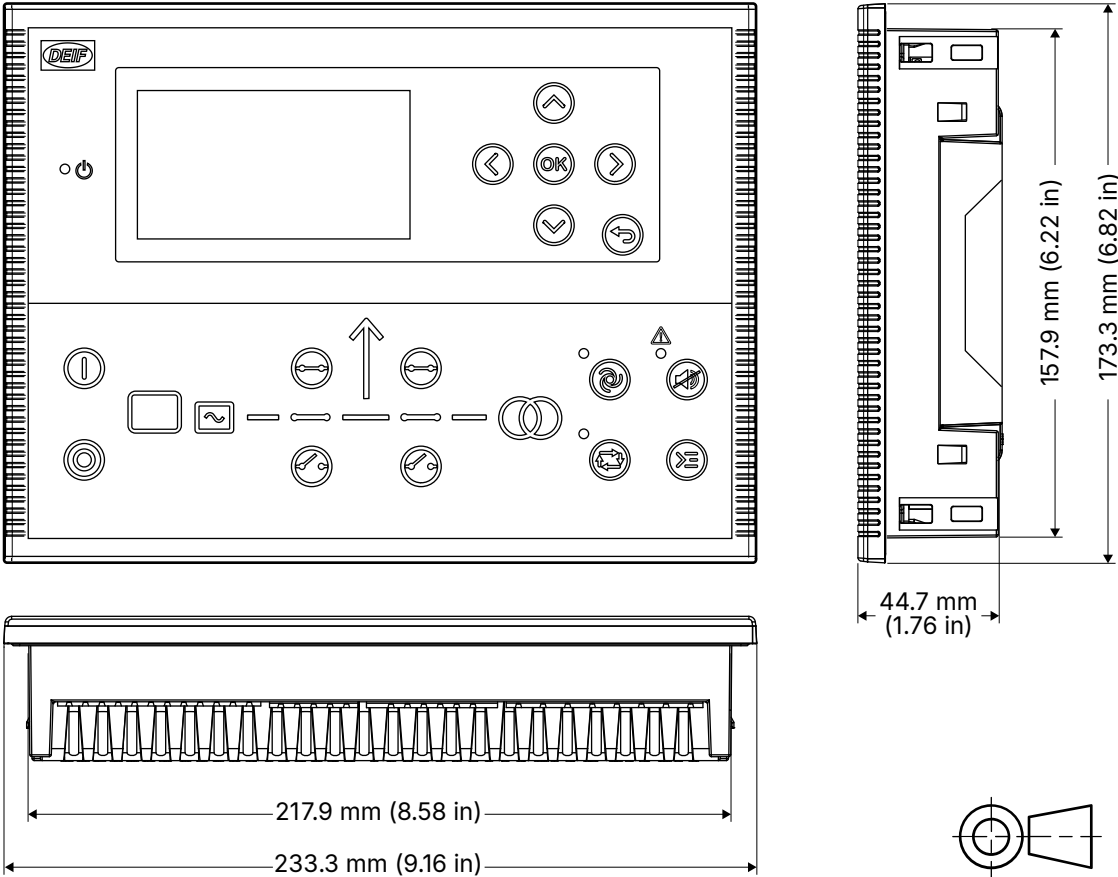

Dimensions and weight

Dimensions	Length: 233.3 mm (9.16 in) Height: 173.3 mm (6.82 in) Depth: 44.7 mm (1.76 in)
Panel cutout	Length: 218.5 mm (8.60 in) Height: 158.5 mm (6.24 in) Tolerance: ± 0.3 mm (0.01 in)
Max. panel thickness	4.5 mm (0.18 in)
Mounting	UL/cUL Listed: Type complete device, open type 1 UL/cUL Listed: For use on a flat surface of a type 1 enclosure
Weight	0.79 kg

3.2 Tools and materials

Tools required for mounting

Tool	Used for
Safety equipment	Personal protection, according to local standards and requirements
Screwdriver, PH2 or 5 mm flat	Tighten the fixing screw clamps, torque 0.15 N·m (1.3 lb-in)
Wire stripper, pliers and cutters	Prepare wiring and trim cable ties

NOTICE



Too much torque damages the screw clamps and/or controller housing

Do not use power tools during the installation.

Materials required for mounting and wiring

Materials	Used for
Four screw clamps	Mounting the controller in the front panel
Wires and connectors	Wiring third party equipment to the controller terminals
Ethernet cable	Connecting the controller communication between controllers and/or external systems
Cable ties	Securing wiring and Ethernet cable

3.3 Mounting instructions

The controller is designed for mounting in the panel front. Max. panel thickness: 4.5 mm (0.18 in).

Panel cutout:

- Width: 218.5 mm (8.60 in)
- Height: 158.5 mm (6.24 in)
- Tolerance: ± 0.3 mm (0.01 in)

1. Insert the controller in the panel.
2. Insert the screw clamps:

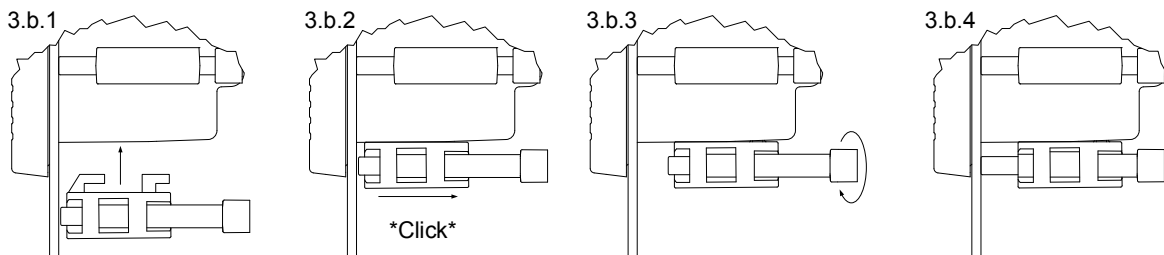

3. Tighten the screw clamps to 0.2 Nm.

4. Hardware

4.1 Rear side connections

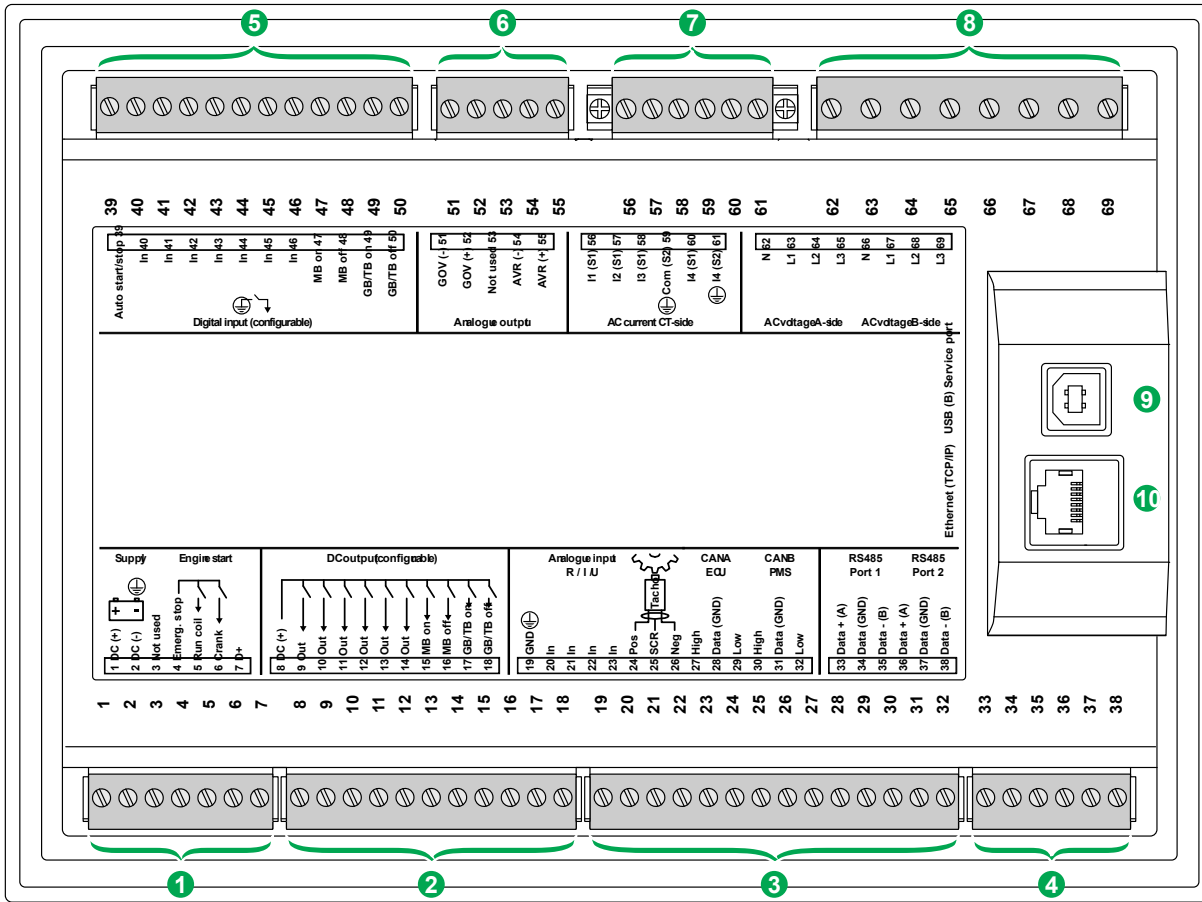

Plug 1: Supply/Engine start

Terminal	Text	Function	Technical data
1	Supply, DC (+)	+12/24 V DC	6.5 to 36 V DC
2	Supply, DC (-)	0 V DC	
3	Not used	-	
4	Emerg. stop	Digital input and supply for terminals 5, 6 and 7	Max. 3 A
5	Run coil	Configurable	
6	Crank	Configurable	Max. 3 A
7	D+		See data sheet for technical data

Plug 2: DC output

Terminal	Text	Function	Technical data
8	Digital output supply, DC (+)		Max. 500 mA
9	Out	Configurable	
10	Out	Configurable	
11	Out	Configurable	
12	Out	Configurable	Max. 500 mA

Terminal	Text	Function	Technical data
13	Out	Configurable	Max. 500 mA
14	Out	Configurable	Max. 500 mA
15	MB on	MB/TB close Configurable (application dependent)	Max. 500 mA
16	MB off	MB/TB open Configurable (application dependent)	Max. 500 mA
17	GB/TB on	GB/TB/BTB/ESB/PVB close Configurable (application dependent)	Max. 500 mA
18	GB/TB off	GB/TB/BTB/ESB/PVB open Configurable (application dependent)	Max. 500 mA

Plug 3: Analogue input/MPU/CANbus

Terminal	Text	Function	Technical data
19	GND	Common	Must be grounded to Engine GND
20	In	Analogue input R/I/U	
21	In	Analogue input R/I/U	
22	In	Analogue input R/I/U	
23	In	Analogue input R/I/U	
24	Pos.	Tacho MPU, NPN, PNP, or W input	
25	SCR	Tacho MPU, NPN, PNP, or W input	
26	Neg	Tacho MPU, NPN, PNP, or W input	
27	High	CAN A ECU	Not isolated
28	Data (GND)	CAN A ECU	Not isolated
29	Low	CAN A ECU	Not isolated
30	High	CAN B PMS	Isolated
31	Data (GND)	CAN B PMS	Isolated
32	Low	CAN B PMS	Isolated

Plug 4: RS-485

Terminal	Text	Function	Technical data
33	Data + (A)	RS-485-1	Isolated
34	Data (GND)	RS-485-1	Isolated
35	Data - (B)	RS-485-1	Isolated
36	Data + (A)	RS-485-2	Not isolated
37	Data (GND)	RS-485-2	Not isolated
38	Data - (B)	RS-485-2	Not isolated

Plug 5: Digital input

Terminal	Text	Function	Technical data
39	In	Configurable	Negative switching only, < 100 Ω
40	In	Configurable	Negative switching only, < 100 Ω
41	In	Configurable	Negative switching only, < 100 Ω

Terminal	Text	Function	Technical data
42	In	Configurable	Negative switching only, < 100 Ω
43	In	Configurable	Negative switching only, < 100 Ω
44	In	Configurable	Negative switching only, < 100 Ω
45	In	Configurable	Negative switching only, < 100 Ω
46	In	Configurable	Negative switching only, < 100 Ω
47	MB on	MB/TB closed* Configurable (application dependent)	Negative switching only, < 100 Ω
48	MB off	MB/TB open* Configurable (application dependent)	Negative switching only, < 100 Ω
49	GB/TB on	GB/TB/BTB/ESB/PVB closed* Configurable (application dependent)	Negative switching only, < 100 Ω
50	GB/TB off	GB/TB/BTB/ESB/PVB open* Configurable (application dependent)	Negative switching only, < 100 Ω

NOTE * Alternatively, if you need [wire break detection](#), you can use multi-input 20/21/22/23.

Plug 6: Analogue output

Terminal	Text	Function	Technical data
51	GOV (-)	Voltage or PWM output	Isolated
52	GOV (+)	Voltage or PWM output	Isolated
53	Not used	-	-
54	AVR (-)	Voltage output	Isolated
55	AVR (+)	Voltage output	Isolated

Plug 7: AC current CT-side

Terminal	Text	Function	Technical data
56	L1 (S1)		
57	L2 (S1)		
58	L3 (S1)		
59	Com (S2)	Common	Must be connected to frame GND
60	L4 (S1)	Neutral, Earth or Mains/Tie/Busbar power	
61	L4 (S2)	Neutral, Earth or Mains/Tie/Busbar power	Must be connected to frame GND

Plug 8: AC voltage measurement

Terminal	Text	Function	Technical data
62	N	A-side	
63	L1	A-side	
64	L2	A-side	
65	L3	A-side	
66	N	B-side	
67	L1	B-side	

Terminal	Text	Function	Technical data
68	L2	B-side	
69	L3	B-side	

Plug 9: PC connection

Description	Function	Technical data
USB connection	Service port	USB B

Plug 10: Modbus connection

Description	Function	Technical data
RJ45	Modbus TCP/IP connection	Ethernet

5. Wiring

5.1 Wiring overview

5.1.1 Typical wiring for generator controller

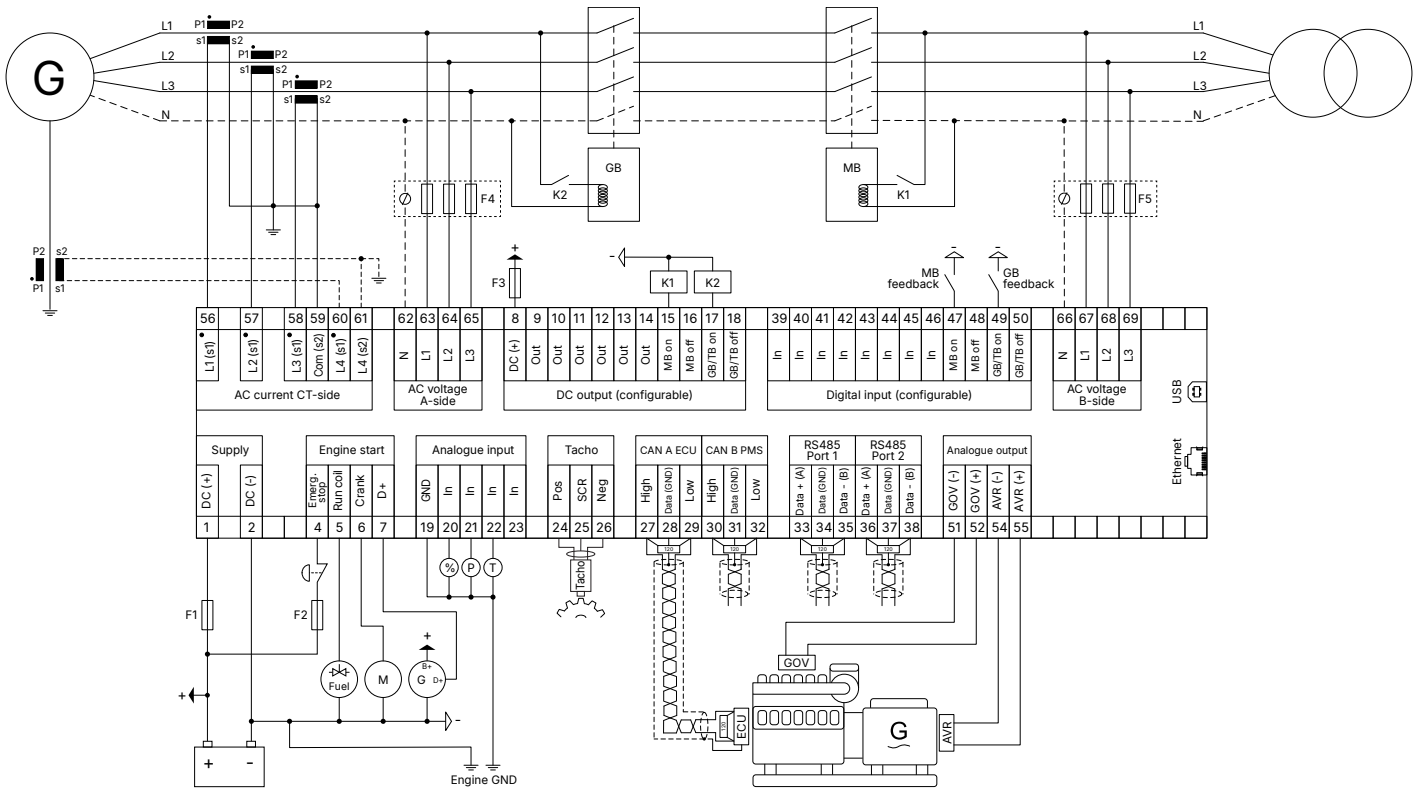

Fuses

- F1: 2 A DC max. time-delay fuse/MCB, c-curve
- F2: 6 A DC max. time-delay fuse/MCB, c-curve
- F3: 4 A DC max. time-delay fuse/MCB, b-curve
- F4, F5: 2 A AC max. time-delay fuse/MCB, c-curve

5.1.2 Typical wiring for mains controller

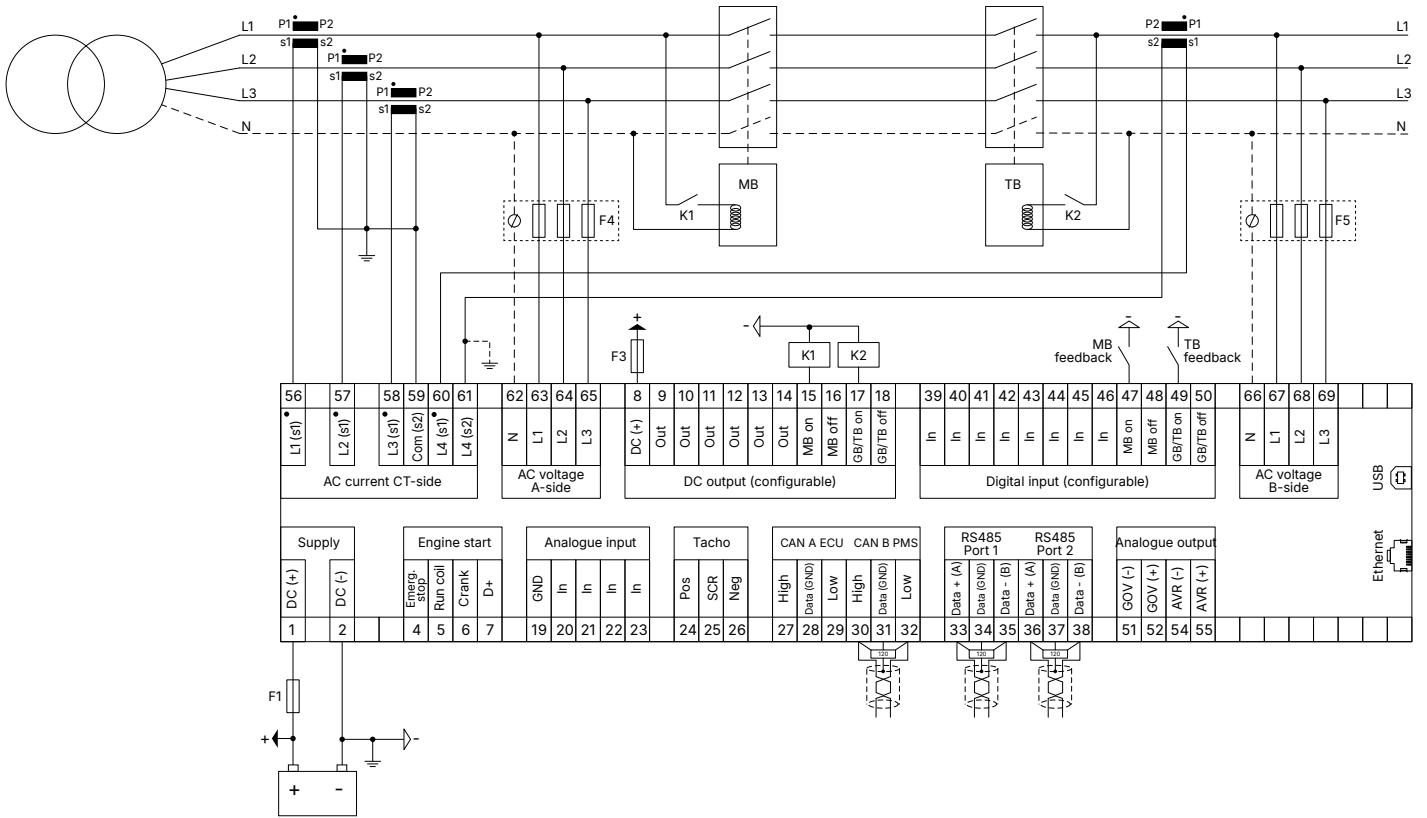

Fuses

- F1: 2 A DC max. time-delay fuse/MCB, c-curve
- F3: 4 A DC max. time-delay fuse/MCB, b-curve
- F4, F5: 2 A AC max. time-delay fuse/MCB, c-curve

5.1.3 Typical wiring for BTB controller

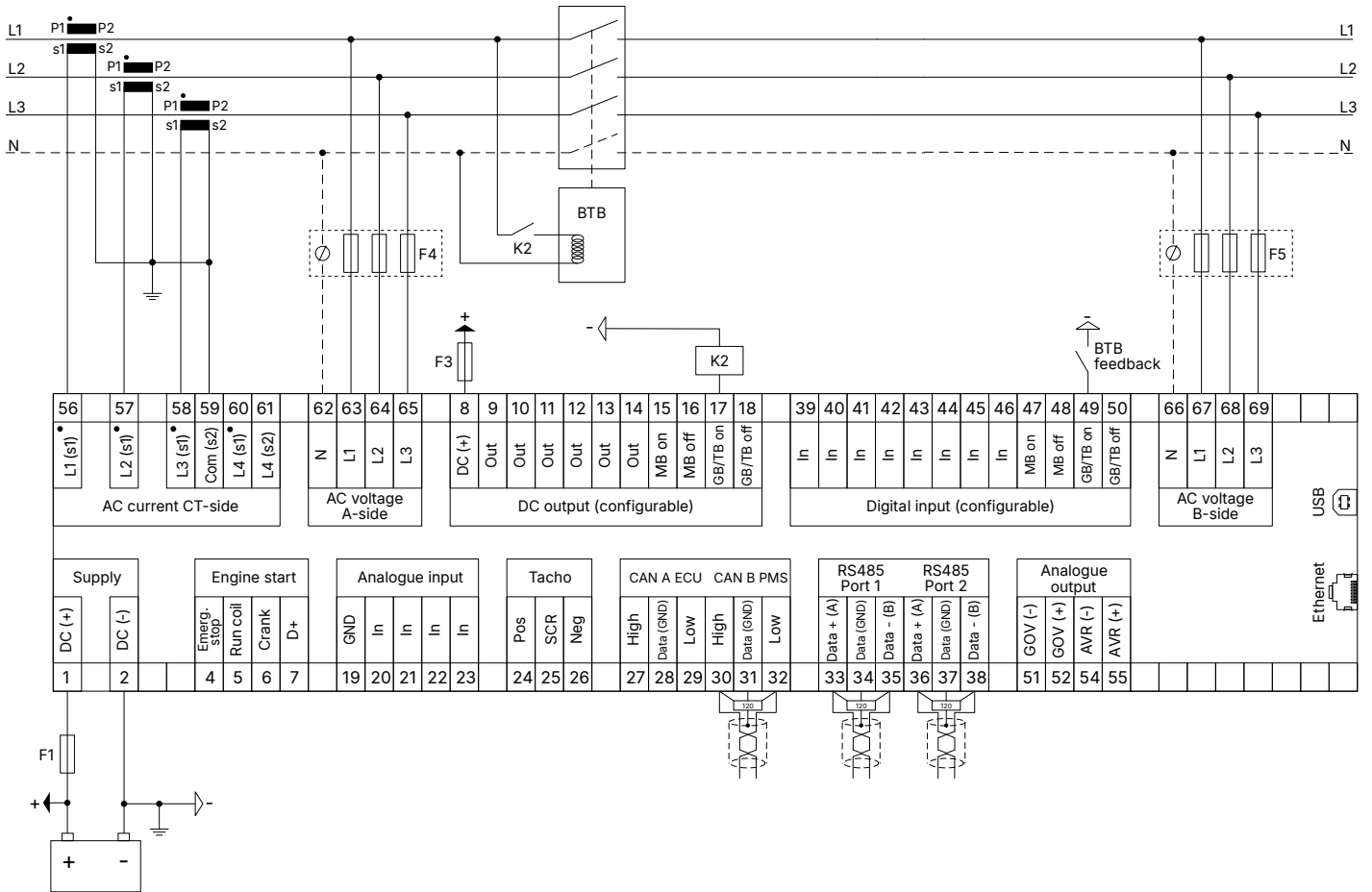

Fuses

- F1: 2 A DC max. time-delay fuse/MCB, c-curve
- F3: 4 A DC max. time-delay fuse/MCB, b-curve
- F4, F5: 2 A AC max. time-delay fuse/MCB, c-curve

5.1.4 Typical wiring for stand-alone controller

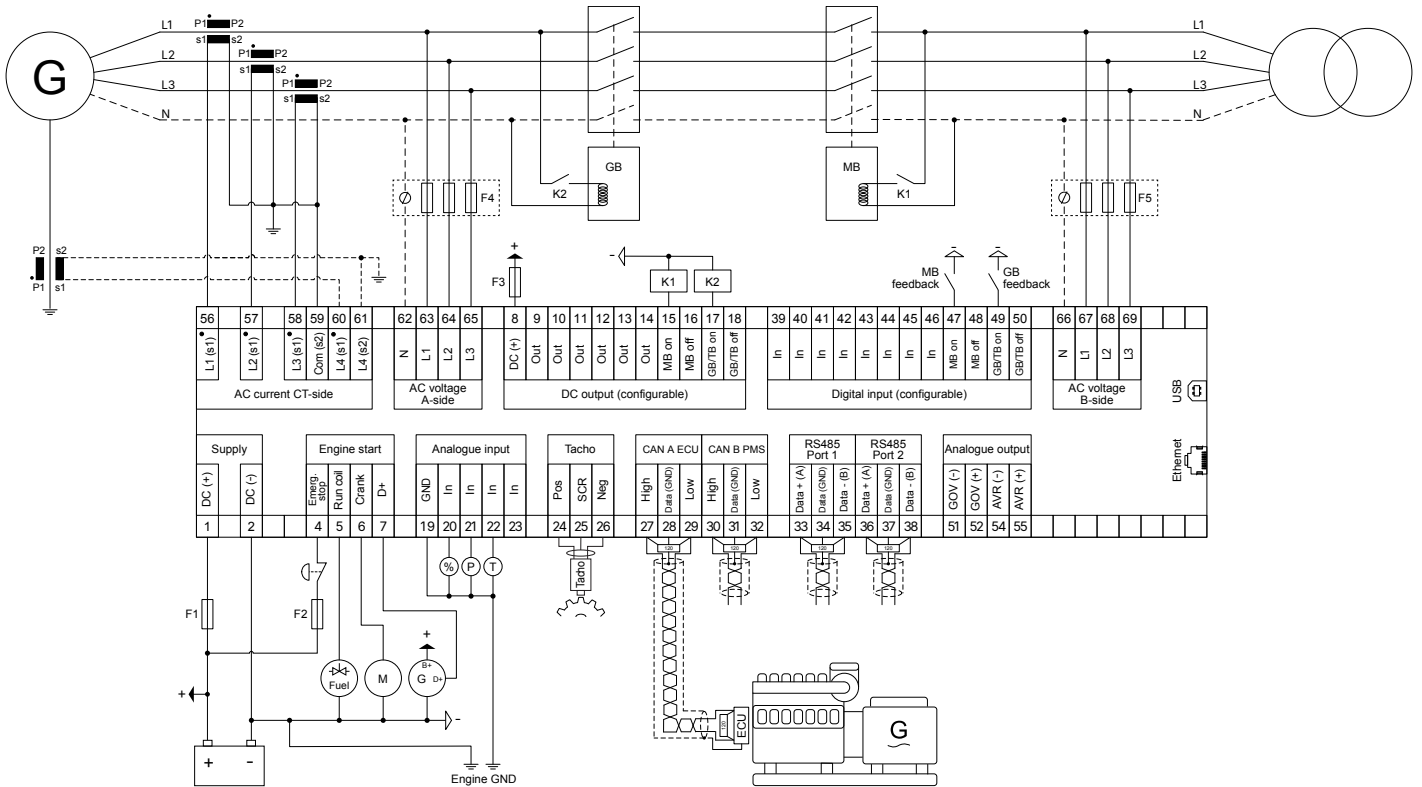

Fuses

- F1: 2 A DC max. time-delay fuse/MCB, c-curve
- F2: 6 A DC max. time-delay fuse/MCB, c-curve
- F3: 4 A DC max. time-delay fuse/MCB, b-curve
- F4, F5: 2 A AC max. time-delay fuse/MCB, c-curve

5.1.5 Typical wiring for marine generator stand-alone controller

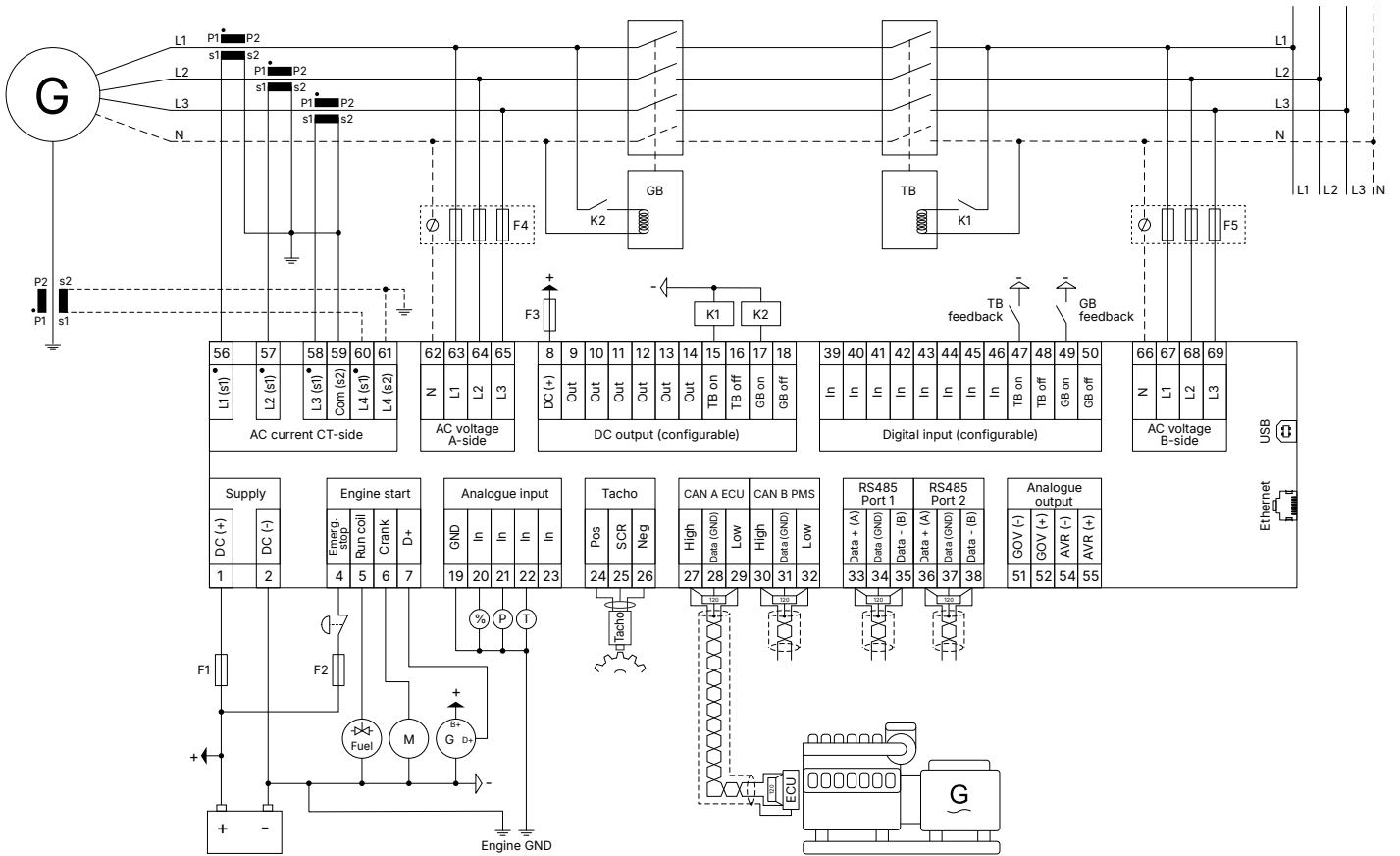

Fuses

- F1: 2 A DC max. time-delay fuse/MCB, c-curve
- F2: 6 A DC max. time-delay fuse/MCB, c-curve
- F3: 4 A DC max. time-delay fuse/MCB, b-curve
- F4, F5: 2 A AC max. time-delay fuse/MCB, c-curve

Typical wiring for marine generator stand-alone controller with GS-box for galvanic separation

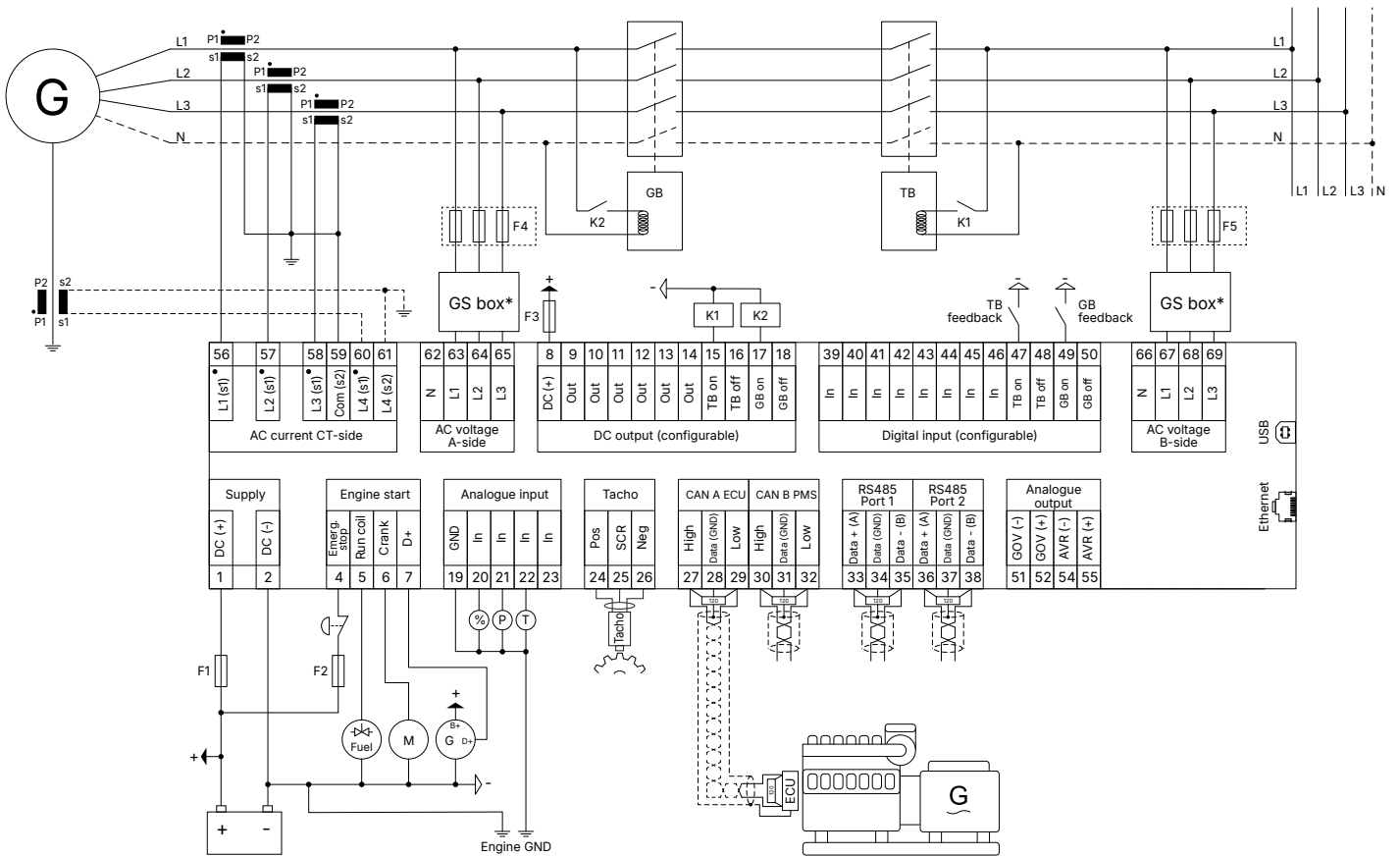

NOTE * One GS-box provides galvanic separation for both sets of voltage measurements.

See previous diagram for fuse information.

5.1.6 Typical wiring for hybrid genset controller

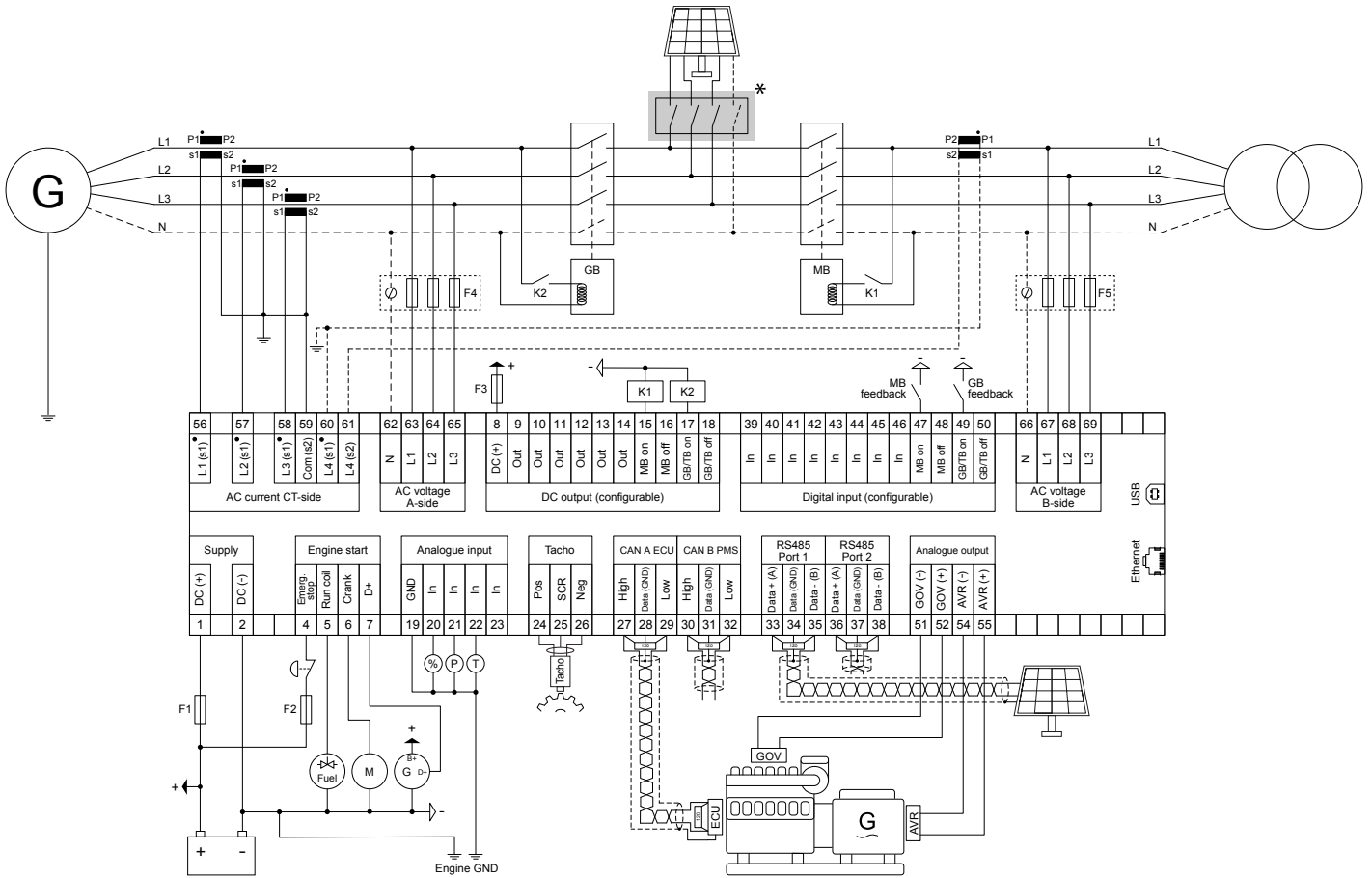

NOTE * Optional PV breaker.

NOTE RS-485 port 1 has galvanic isolation, and RS-485 port 2 does not have galvanic isolation. Port 1 is recommended for communication with the solar inverter.

Fuses

- F1: 2 A DC max. time-delay fuse/MCB, c-curve
- F2: 6 A DC max. time-delay fuse/MCB, c-curve
- F3: 4 A DC max. time-delay fuse/MCB, b-curve
- F4, F5: 2 A AC max. time-delay fuse/MCB, c-curve

5.1.7 Typical wiring for engine drive controller

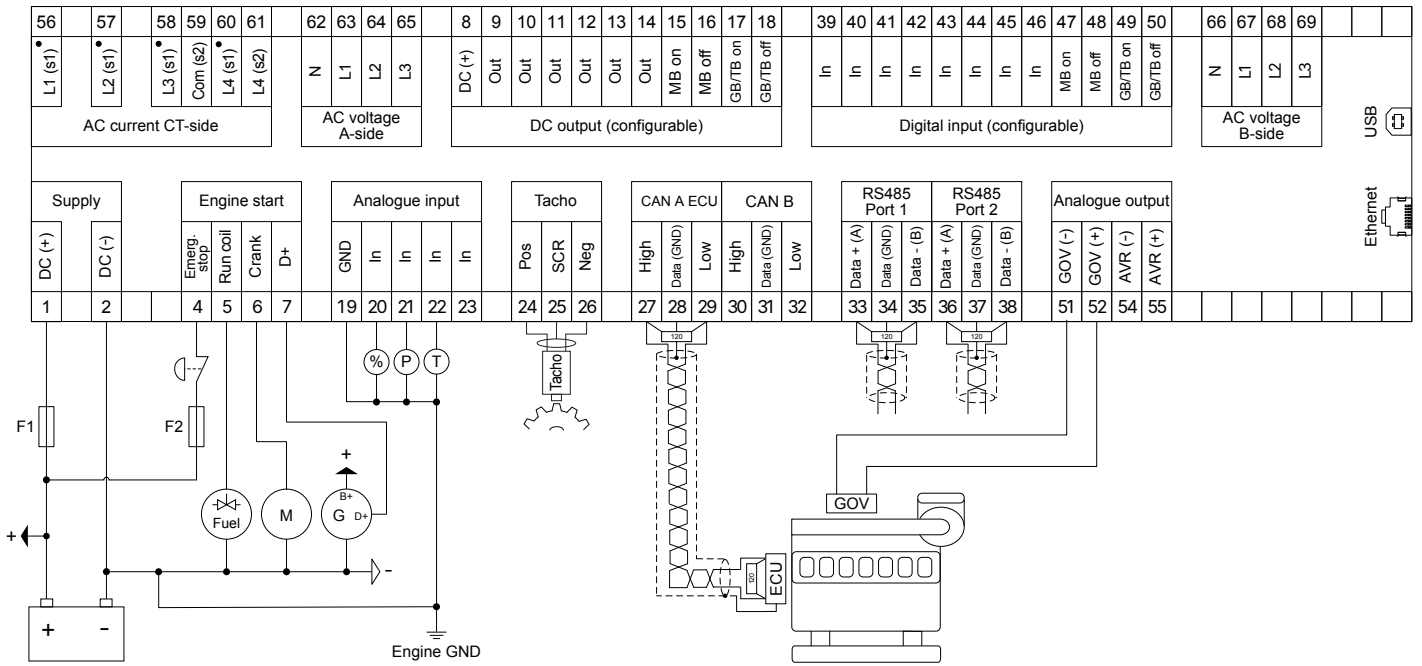

Fuses

- F1: 2 A DC max. time-delay fuse/MCB, c-curve
- F2: 6 A DC max. time-delay fuse/MCB, c-curve

5.1.9 Typical wiring for solar controller

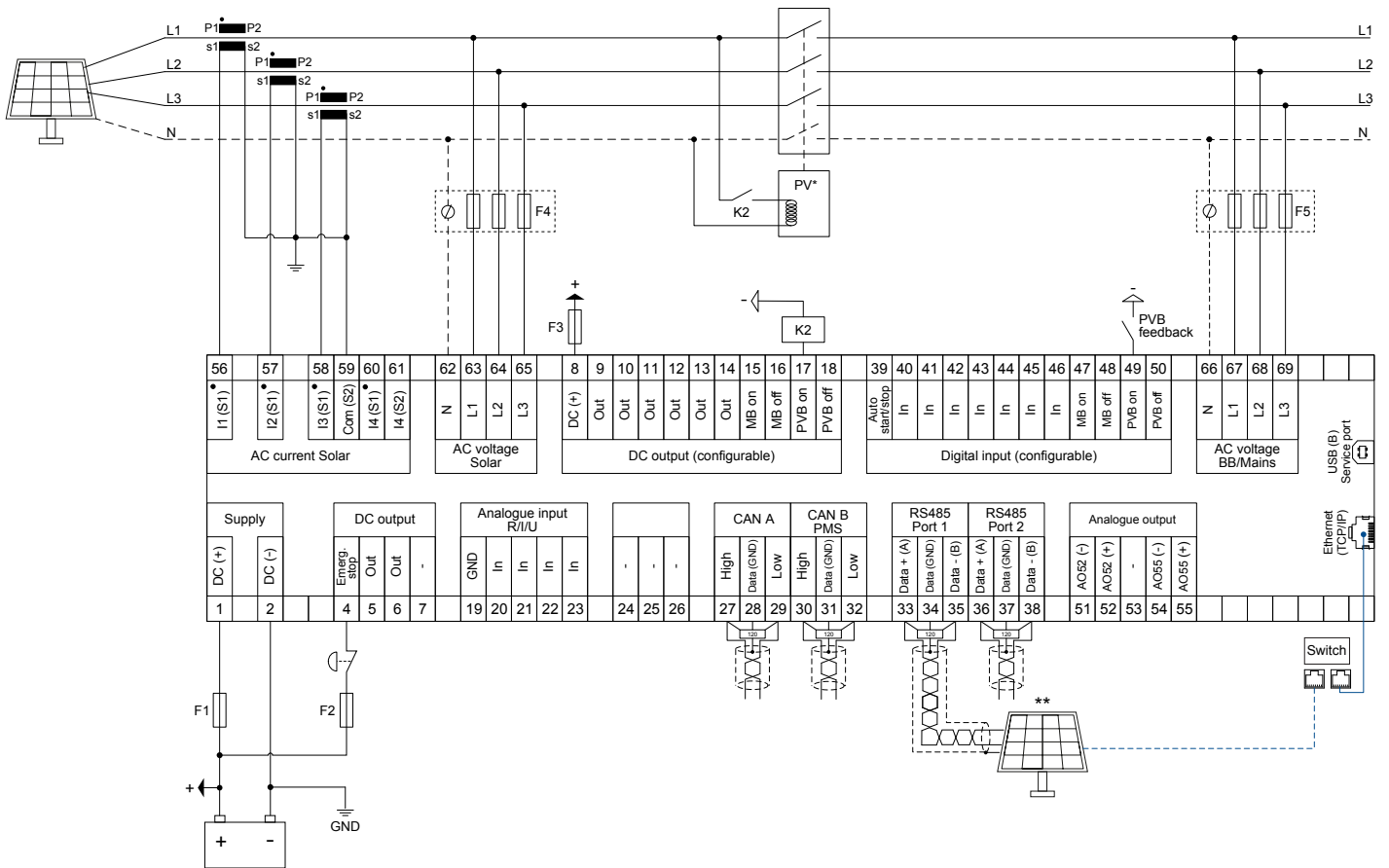

NOTE * PV breaker: Optional PV breaker.

NOTE ** Communication with PV inverter: The controller can use RS-485 or Ethernet communication.

NOTE RS-485 port 1 has galvanic isolation, and RS-485 port 2 does not have galvanic isolation. Port 1 is recommended for communication with the solar inverter.

Fuses:

- F1: 2 A DC max. time-delay fuse/MCB, c-curve
- F2: 6 A DC max. time-delay fuse/MCB, c-curve
- F3: 4 A DC max. time-delay fuse/MCB, b-curve
- F4, F5: 2 A AC max. time-delay fuse/MCB, c-curve

5.1.10 Typical wiring for ATS controller

Typical wiring with 1 breaker and 2 positions

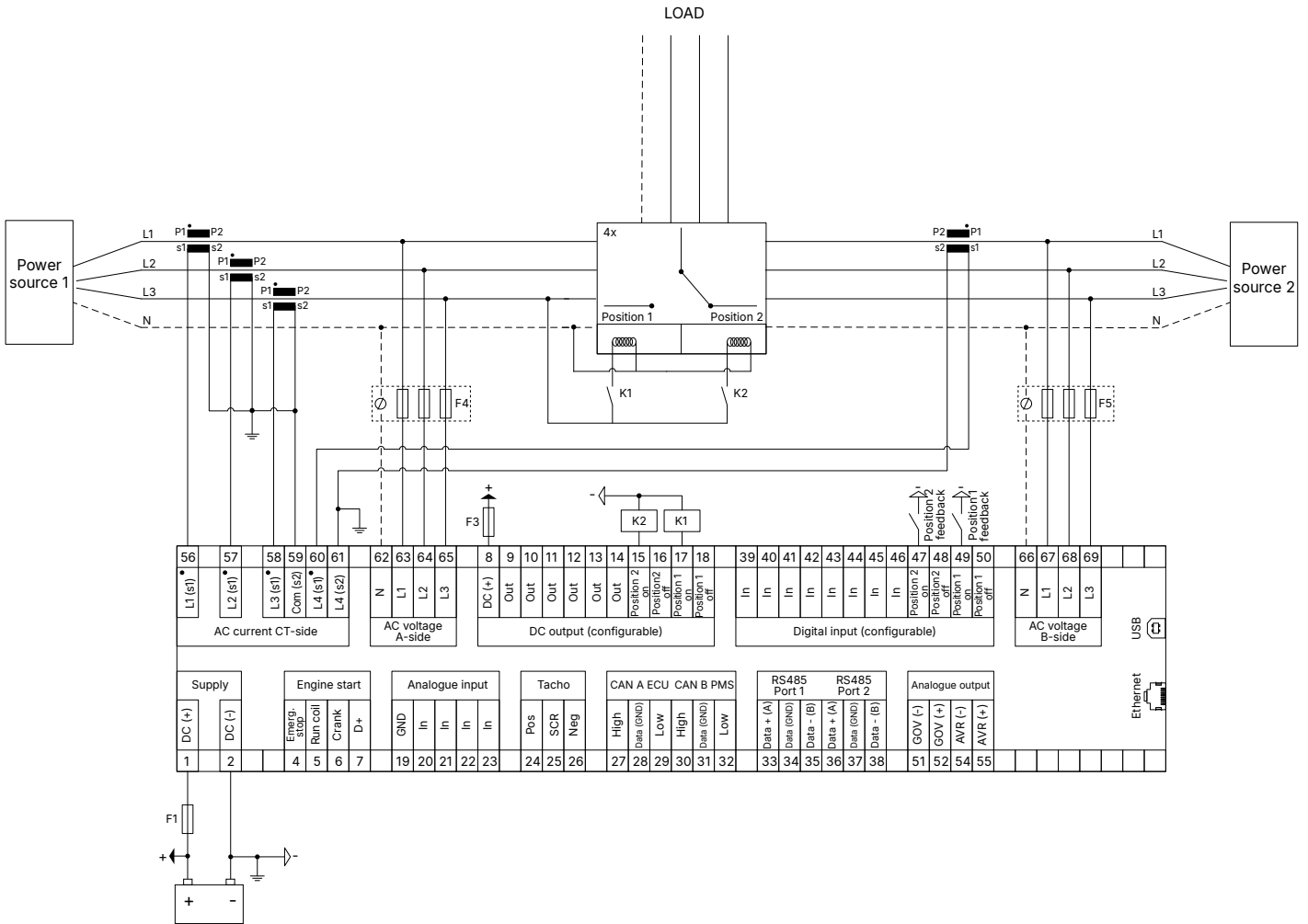

Fuses

- F1: 2 A DC max. time-delay fuse/MCB, c-curve
- F3: 4 A DC max. time-delay fuse/MCB, b-curve
- F4, F5: 2 A AC max. time-delay fuse/MCB, c-curve

5.1.11 Typical wiring for PMS lite controller

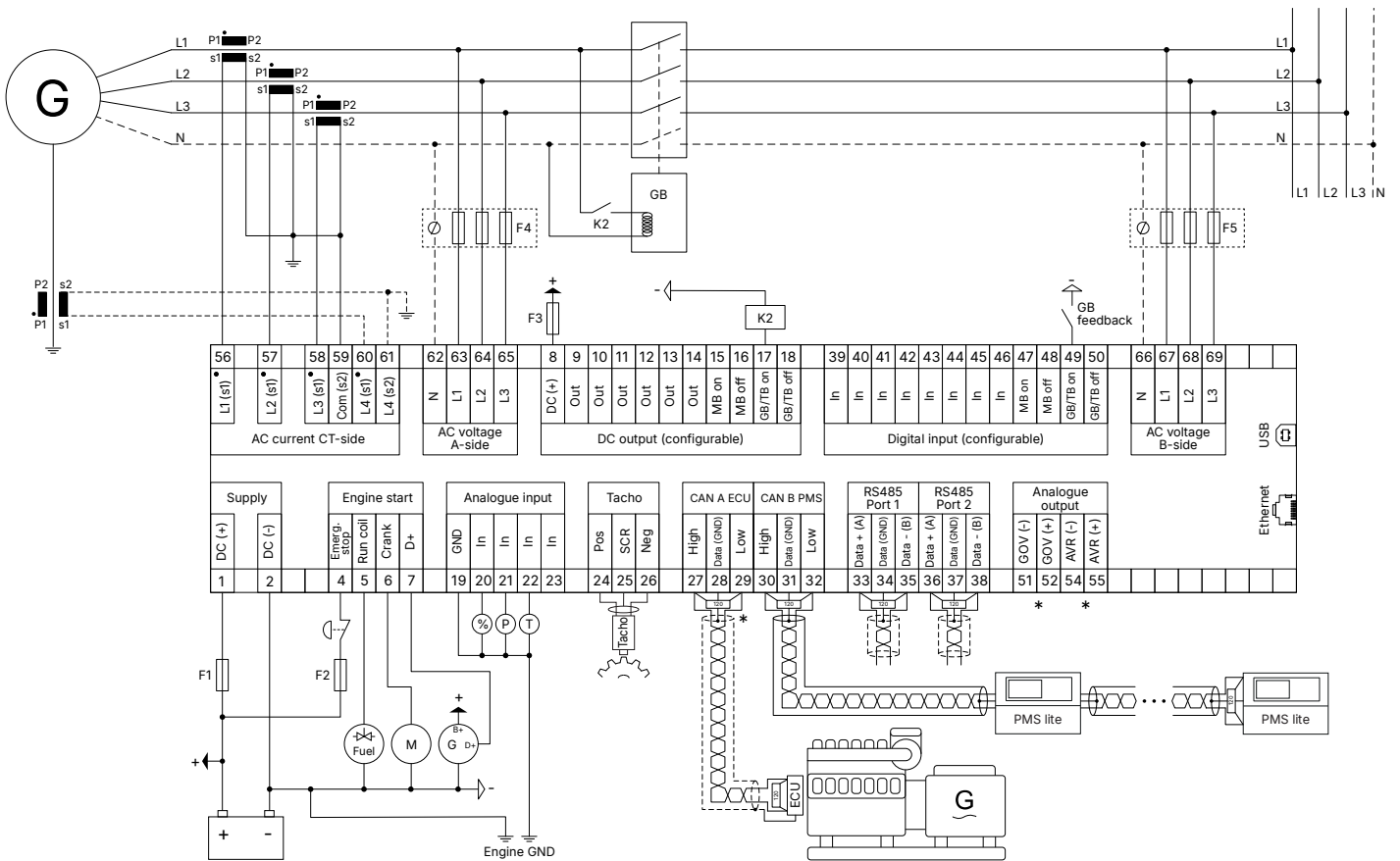

Fuses

- F1: 2 A DC max. time-delay fuse/MCB, c-curve
- F2: 6 A DC max. time-delay fuse/MCB, c-curve
- F3: 4 A DC max. time-delay fuse/MCB, b-curve
- F4, F5: 2 A AC max. time-delay fuse/MCB, c-curve

NOTE * The diagram shows EIC governor regulation. Alternatively, the governor and AVR can be regulated using the analogue outputs.

5.1.12 Wiring guidelines - best practice for grounding

On the controller, most input/output ports are not galvanically separated from the DC- (terminal 2). It is therefore important to follow these wiring guidelines to get:

- Reliable readings from the sensors.
- Precise measurement of AC voltage and current.
- Best protection from lightning (surge pulses) and other earth faults.

The inputs for AC voltage, AC current, and the analogue multi-inputs all have balanced measuring of the signals. To get reliable measurements, it is important to keep the potential difference low to DC- (terminal 2). If the potential difference is too high, the measurements can be inaccurate, and in severe cases damage the input circuitry.

Example: Typical grounding setup

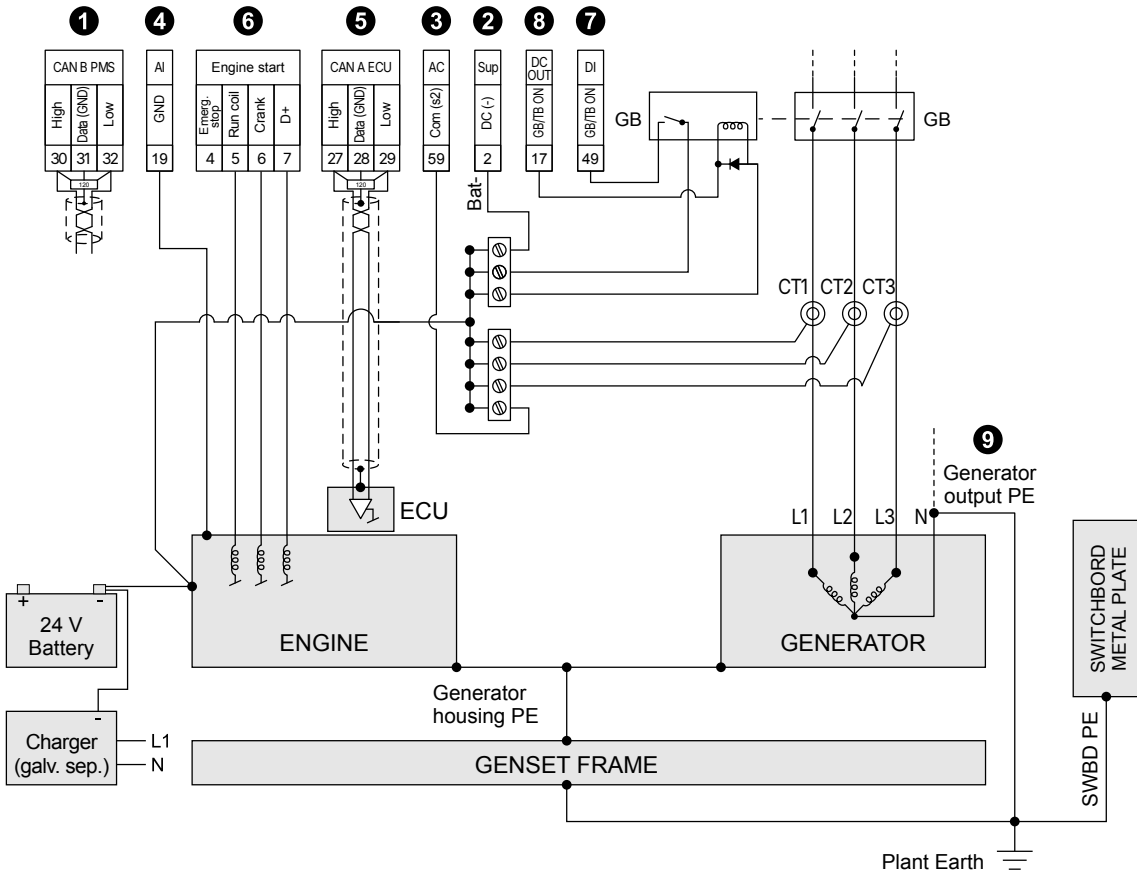

1. CAN-B PMS port (terminals 30, 31 and 32) is normally used with long cables connecting many gensets.
 - Use a twisted pair CAN cable (120R) with shield.
 - Connect the shield to Data (GND) (terminal 31) on all controllers. CAN-B PMS has galvanic separation, so no ground loops are created.
 - Do not connect the shield to PE.
 - Do not install CAN cables as free hanging wires. Mount them as a fixed part of the installation, for example in cable trays.
2. Power supply DC- (terminal 2) must be connected to BAT- (in this example, the engine block).
3. COM S2 (terminal 59) is the common input for the current transformers. COM S2 (terminal 59) must be connected to BAT- or to the genset PE to keep the voltage difference to DC- (terminal 2) low (in this example, the CT's have the same BAT- connection point as terminal 2).
4. Analogue input GND (terminal 19) is the reference for the analogue input measurements. GND (terminal 19) must have a BAT-/PE connection point as the sensor ground. The potential difference to terminal 2 must be low (in this example, terminal 19 is connected to the engine block for best readings).
5. CAN A ECU port (terminals 27, 28 and 29) is normally connected to the engine ECU with a short cable. There is no galvanic separation on the CAN A ECU port.

- Use a twisted pair CAN cable (120R) with shield.
 - Connect the shield to Data (GND) (terminal 28) to improve the immunity to burst transients (EFT).
 - Connect the shield to the engine ECU, as described by the engine manufacturer.
- The signals on Run Coil (terminal 5), Crank (terminal 6) and D+ (terminal 7) must be connected to BAT- on the engine block as reference. These terminals are not supplied internally, but via the Emergency stop. This means that BAT+ must be connected via the Emergency stop (terminal 4).
 - The digital inputs (terminals 39 to 50) must have BAT- as ground reference. The preferred connection point for the reference is close to the BAT- connection point for DC- (terminal 2).
 - The DC outputs (terminals 9 to 18) must have the same ground reference as the digital inputs.
 - Connect Neutral/PE of the generators directly to the plant earth. This prevents short circuits and high energy transients from the grid side to cause severe damage to the system.

NOTE All PE and BAT- wiring must be made with thick and short wires.

5.2 AC connections

The controller can be wired up in three-phase, single phase or split phase configuration. The parameters for setting up the AC connection is found under **Settings > Basic settings > Measurement setup > Wiring connection > AC configuration**.

NOTE Contact the switchboard manufacturer for information about required wiring for the specific application. Wiring suggestions are shown below.

Current transformers for 3-phase application

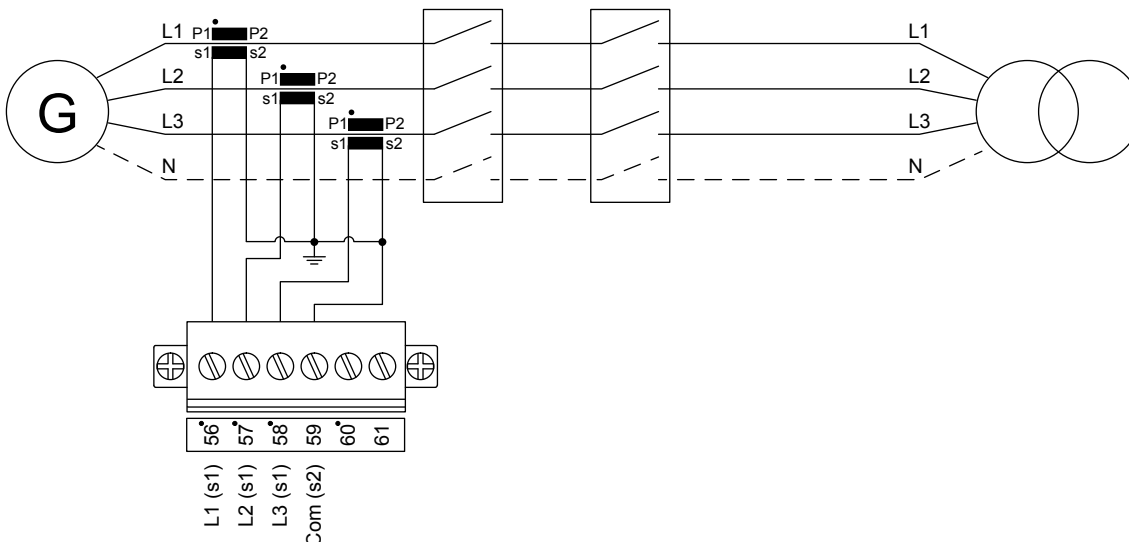

Voltage measurements for 3-phase application (4 wires)

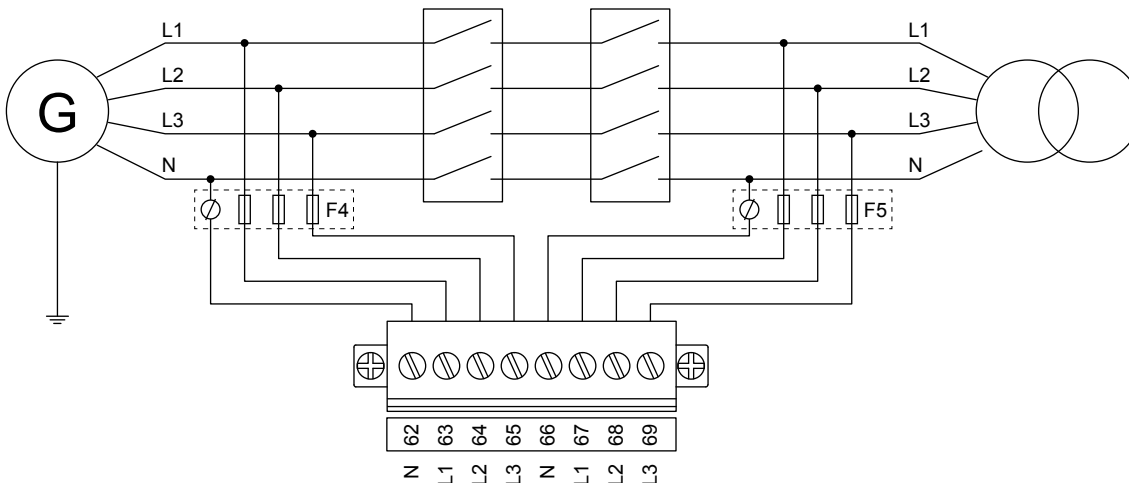

Voltage measurements for 3-phase application (3 wires)

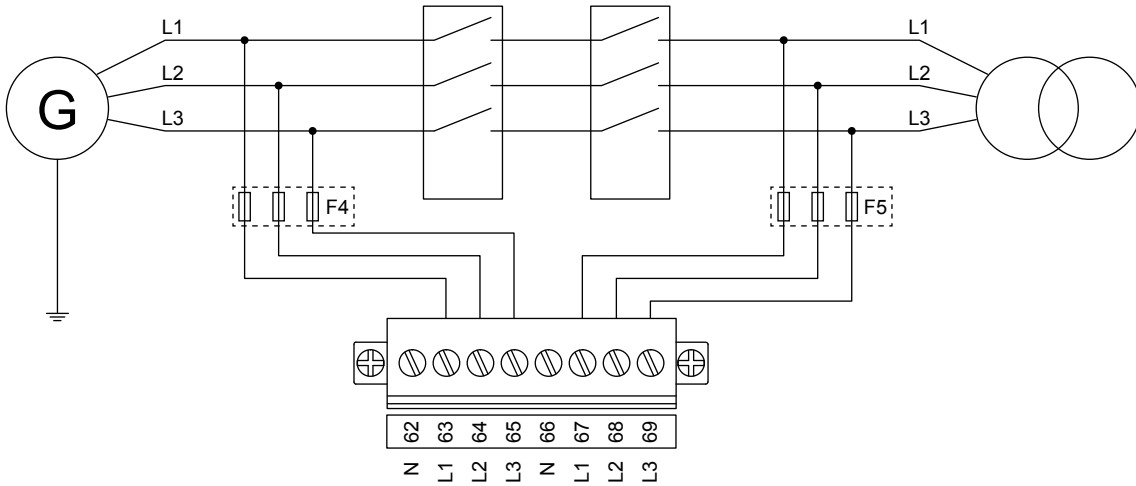

When three-phase distribution systems are used, the neutral line (N) is only necessary if it is a three-phase + neutral system. If the distribution system is a three-phase system without neutral, then do not connect the terminals 62 and 66.

Voltage measurements for single-phase application

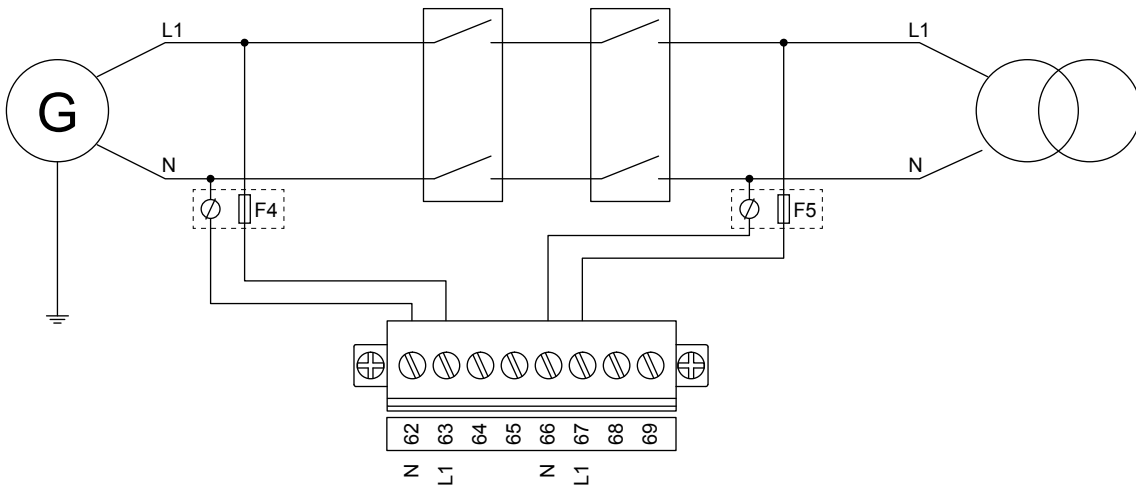

Voltage measurements for split phase L1/L2

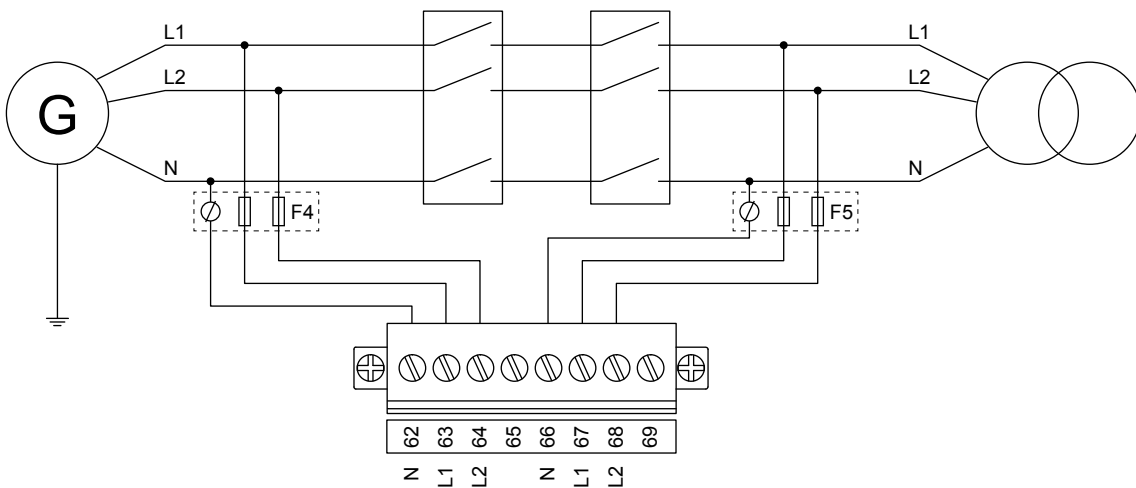

Voltage measurements for split phase L1/L3

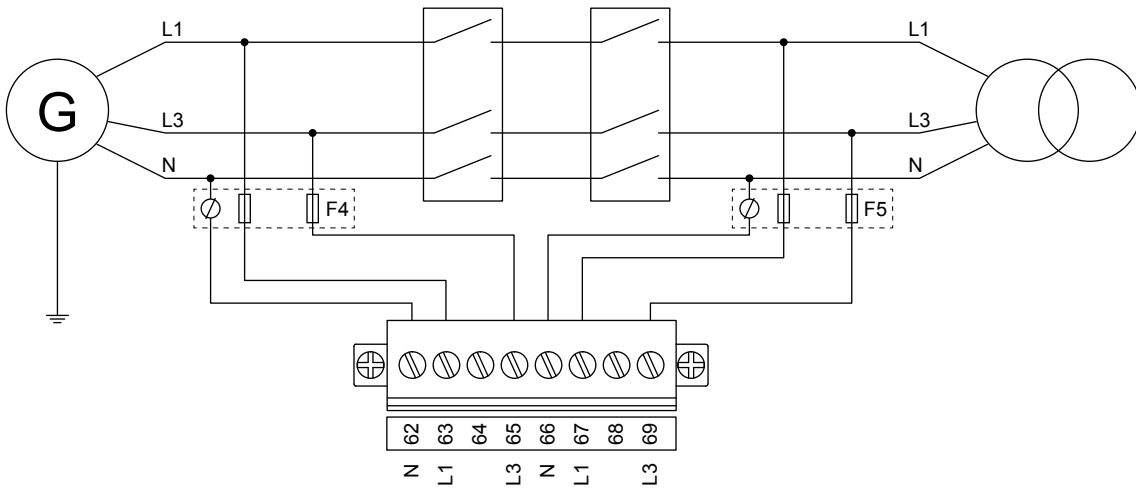

F4, F5: 2 A AC max. fuse/MCB, c-curve

5.2.1 I4 current

The L4 terminals can be used to measure AC current. The following configurations are possible (depending on the controller type).

Mains power

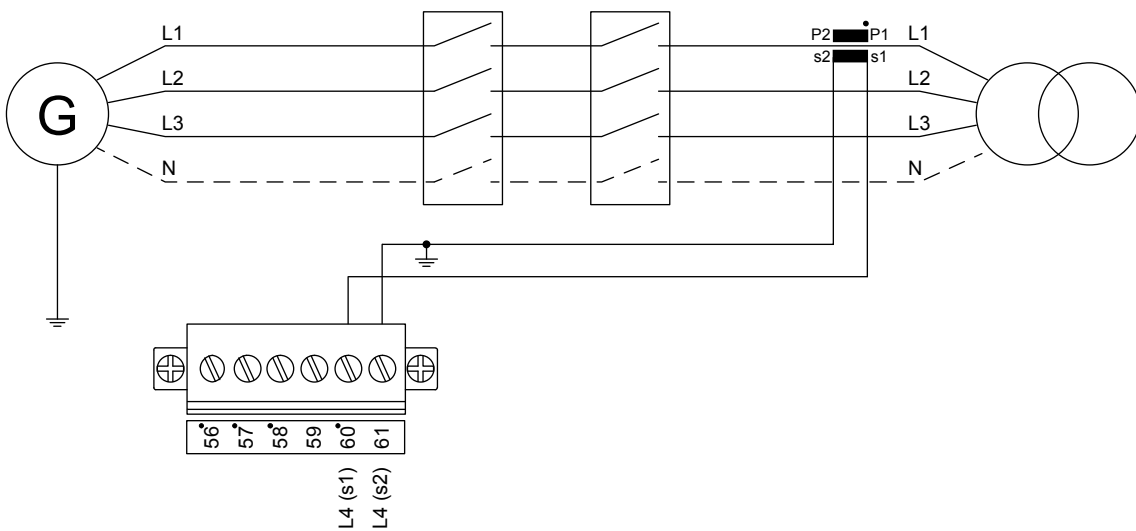

Neutral current

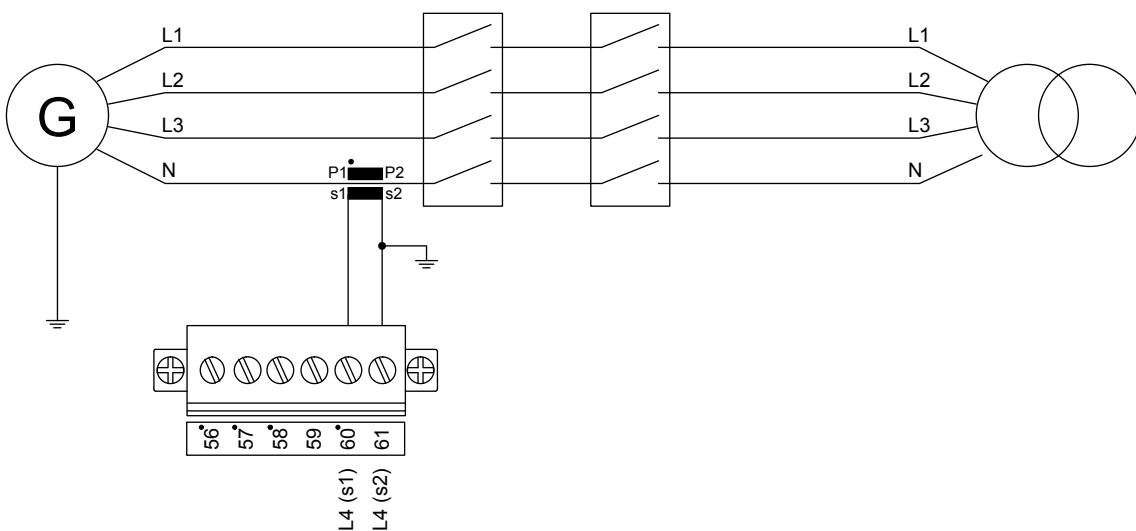

Earth current

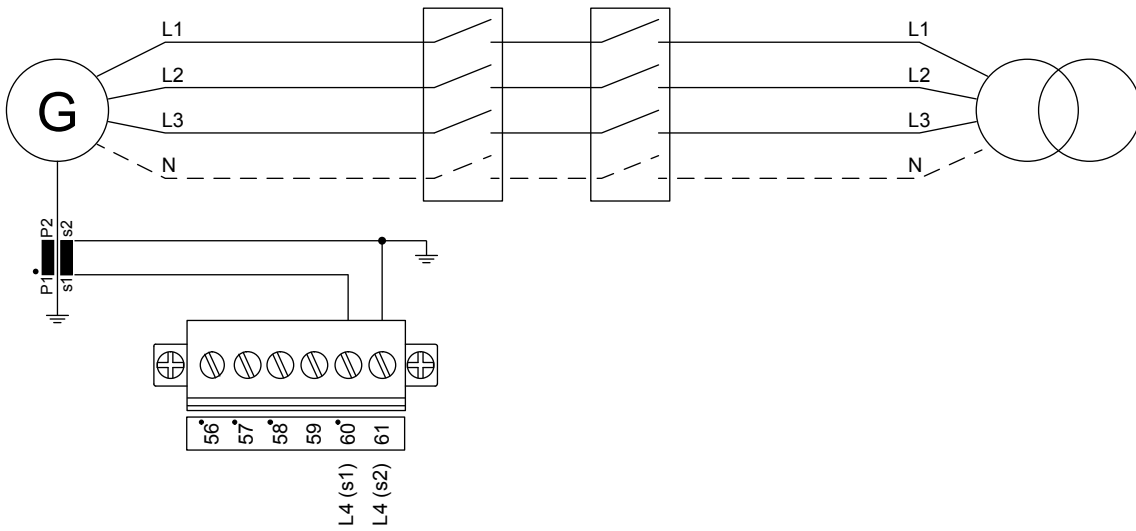

Mains controller tie power

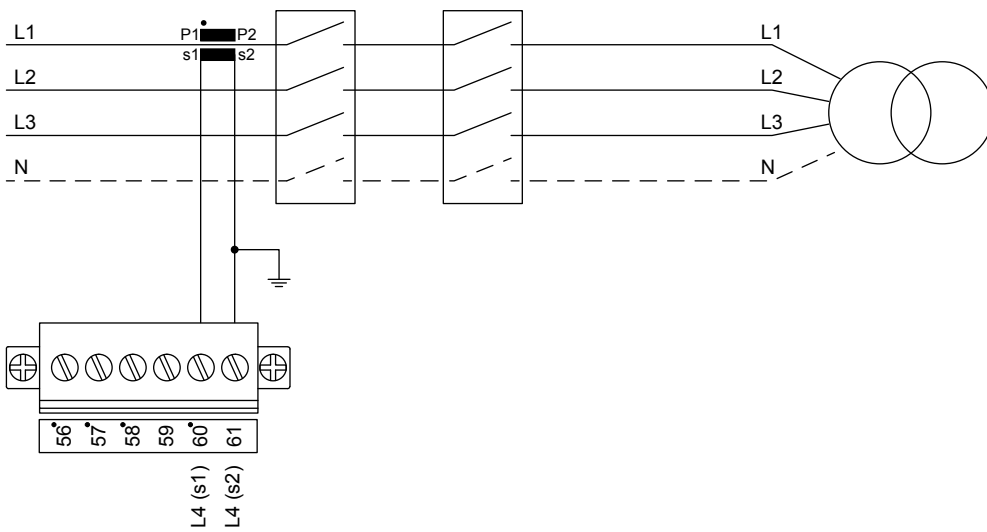

5.2.2 Current transformer ground

The current transformer ground connection must be made on the s2 connection.



DANGER!



Failure to ground a current transformer could lead to injury or death

Make sure that each current transformer is grounded.

5.2.3 Voltage measurement fuses

If the wires/cables must be protected with fuses, use max. 2 A time-delay fuses, dependent on the wires/cables to be protected.

5.3 DC connections

5.3.1 Digital inputs

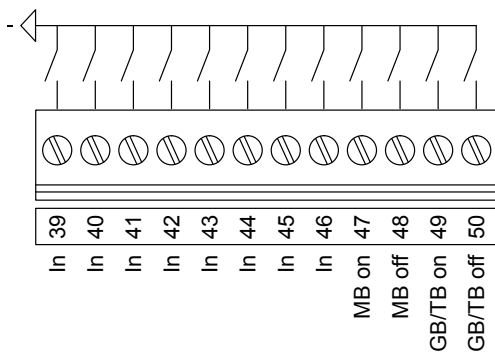

To be EN60255 compliant, when wiring is more than 10 m, a 4007 diode must be connected on each input.

5.3.2 Digital outputs

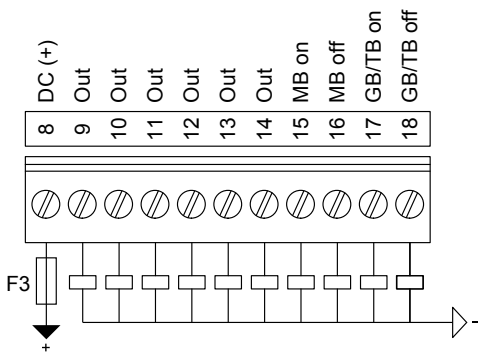

Fuse F3: 4 A DC max. time-delay fuse/MCB, b-curve

5.3.3 Breaker wiring

Pulse breaker wiring

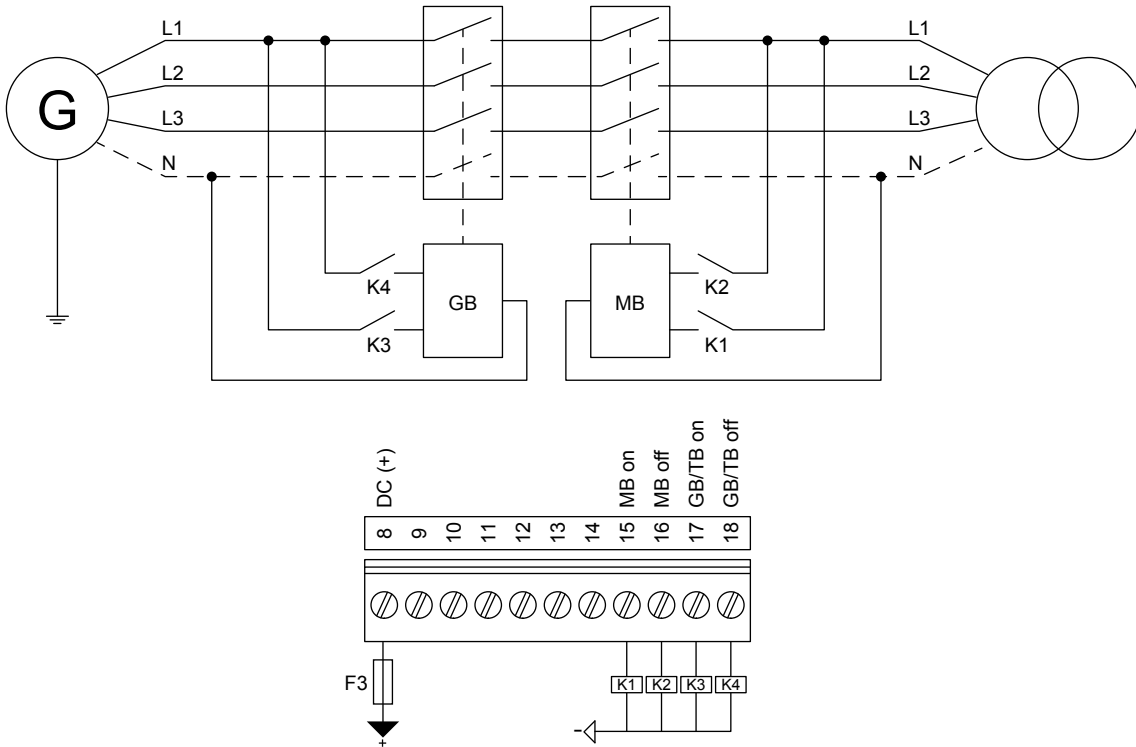

Continuous breaker wiring

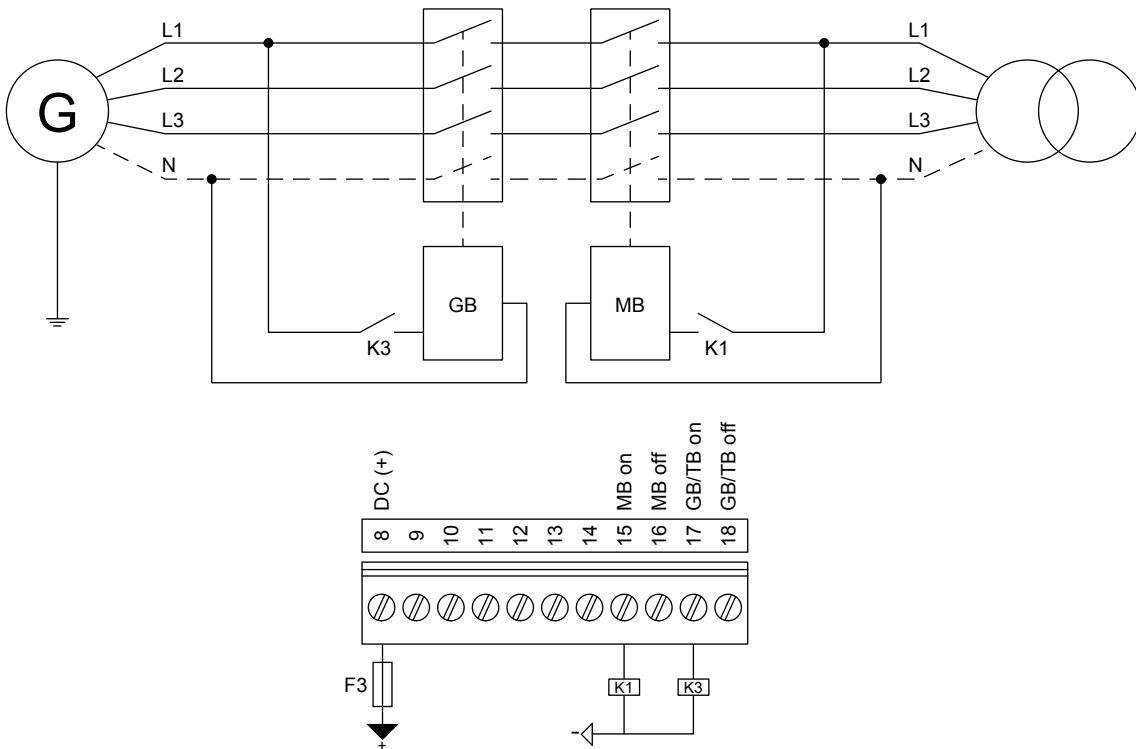

Fuse F3: 4 A DC max. time-delay fuse/MCB, b-curve

Breaker feedbacks

By default, the breaker feedback functions are assigned to specific digital inputs. For example, for a GENSET controller:

- Input 49 = GB Closed
- Input 50 = GB Open
- Input 47 = MB Closed (if there is a mains breaker on the application diagram)

- Input 48 = MB Open (if there is a mains breaker on the application diagram)

For all controllers, you can move any breaker feedback function to any available digital input. Alternatively, you can assign the breaker feedback function to a multi-input with the input type *Binary* (for wire break detection).

5.3.4 Power supply and start

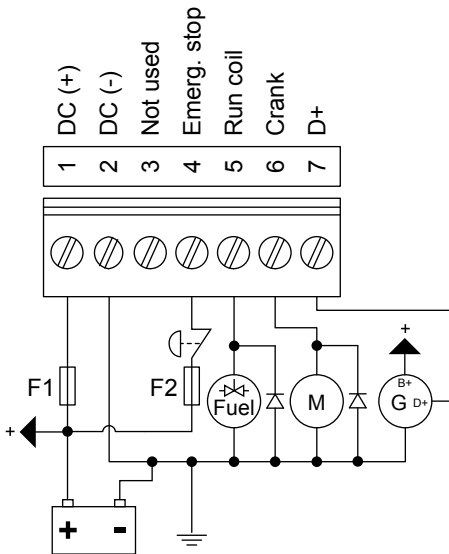

Fuses

- F1: 2 A DC max. time-delay fuse/MCB, c-curve
- F2: 6 A DC max. time-delay fuse/MCB, c-curve

NOTE Remember to mount the freewheeling diodes.

5.3.5 Analogue inputs

Analogue input

All sensors must be wired to the Engine GND.

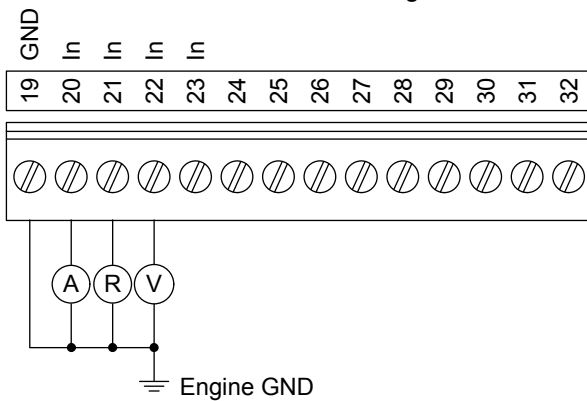

Supervised binary input with wire break detection

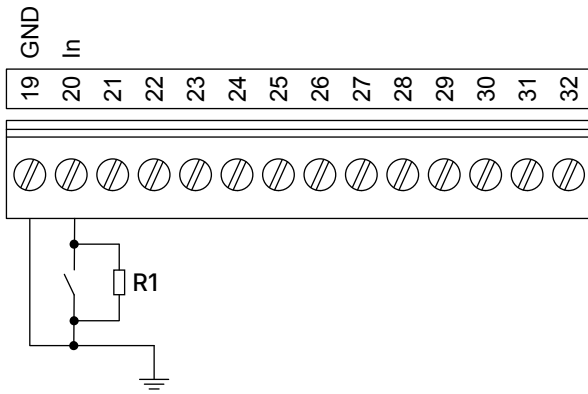

The resistor is only mounted if wire break detection is required. The value of the resistor should be $240\ \Omega \pm 10\%$. A wire break is detected if the resistance is more than $1\ \text{k}\Omega$.

Tacho input (MPU)

Connect the cable shield to terminal 25 (SCR). Do not ground the cable.

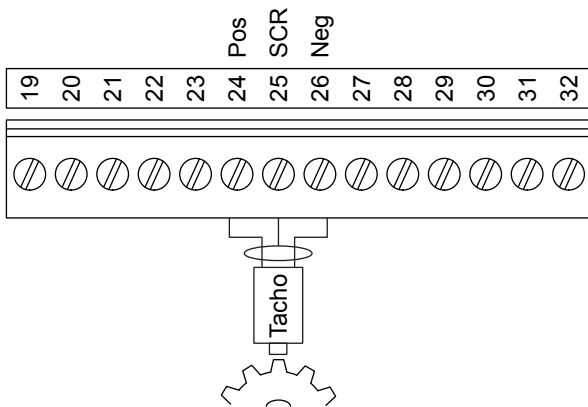

Tacho input (NPN)

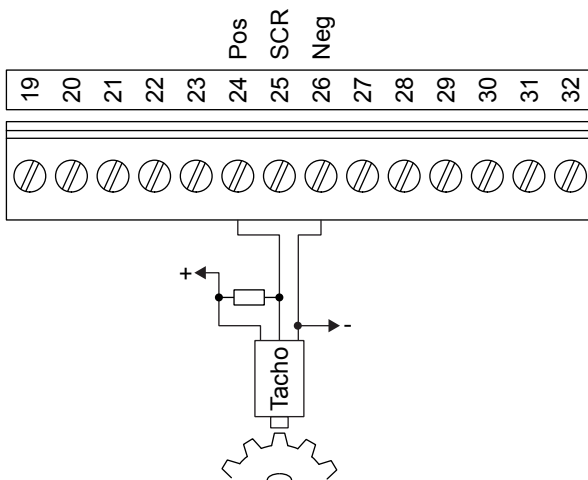

For most 12 V systems use a resistor with a value between $1\ \text{k}\Omega$ and $2.2\ \text{k}\Omega$.

For most 24 V systems use a resistor with a value $2.2\ \text{k}\Omega$.

Tacho input (PNP)

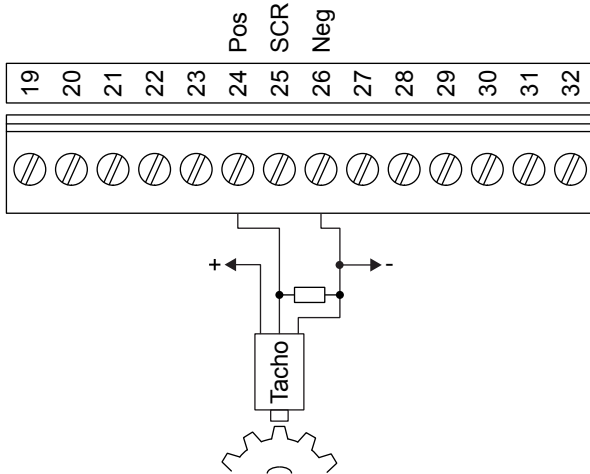

For most 12 V systems use a resistor with a value between 1 k Ω and 2.2 k Ω .

For most 24 V systems use a resistor with a value 2.2 k Ω .

Analogue tacho input (W)

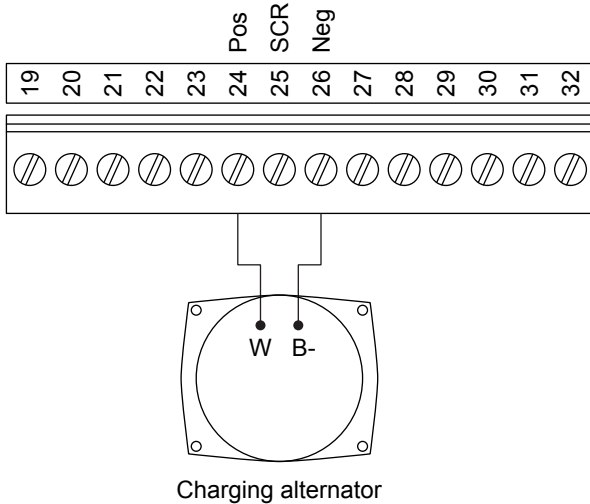

5.4 Communication

5.4.1 CAN bus and RS-485 cable recommendation

Use a shielded twisted cable. Use a 120 ohm resistor at each end. Wiring that uses a two-wire cable is acceptable. Wiring that uses a three-wire cable is best.

NOTE If the device terminals are not galvanically separated, ground the cable shield at that end.

NOTE The system must not have more than one ground for the cable shield.

DEIF recommends this cable: Belden 3105A or equivalent. 22 AWG (0.6 mm \varnothing , 0.33mm²) twisted pair, shielded, <40 m Ω /m, min. 95 % shield coverage. The cable type is particularly important if the total line length is more than 30 m.

5.4.2 CAN bus power management system, CANshare, and PMS lite

Two-wire example

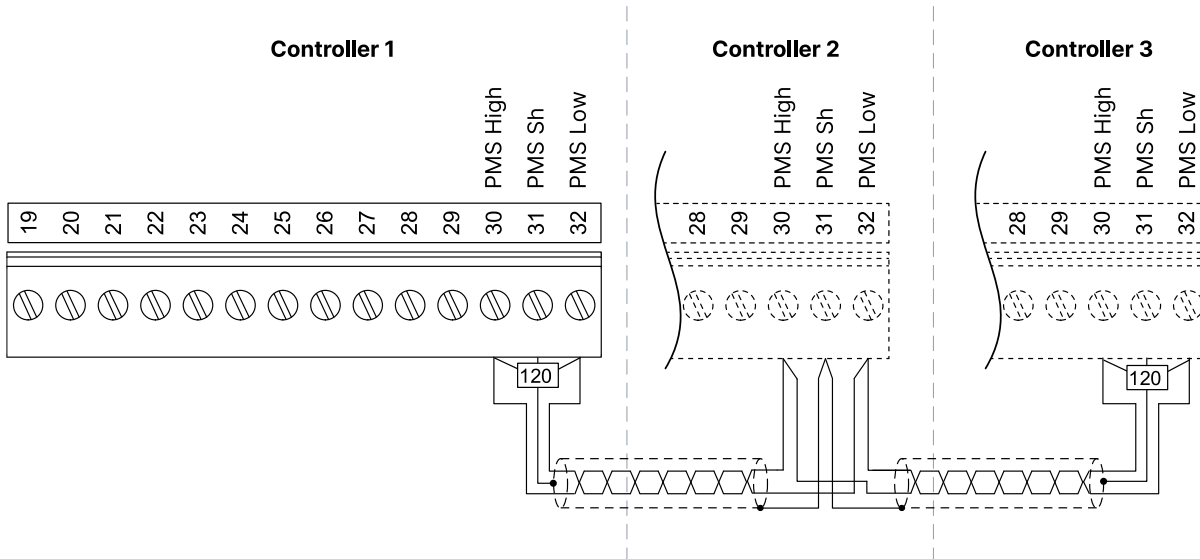

Three-wire example

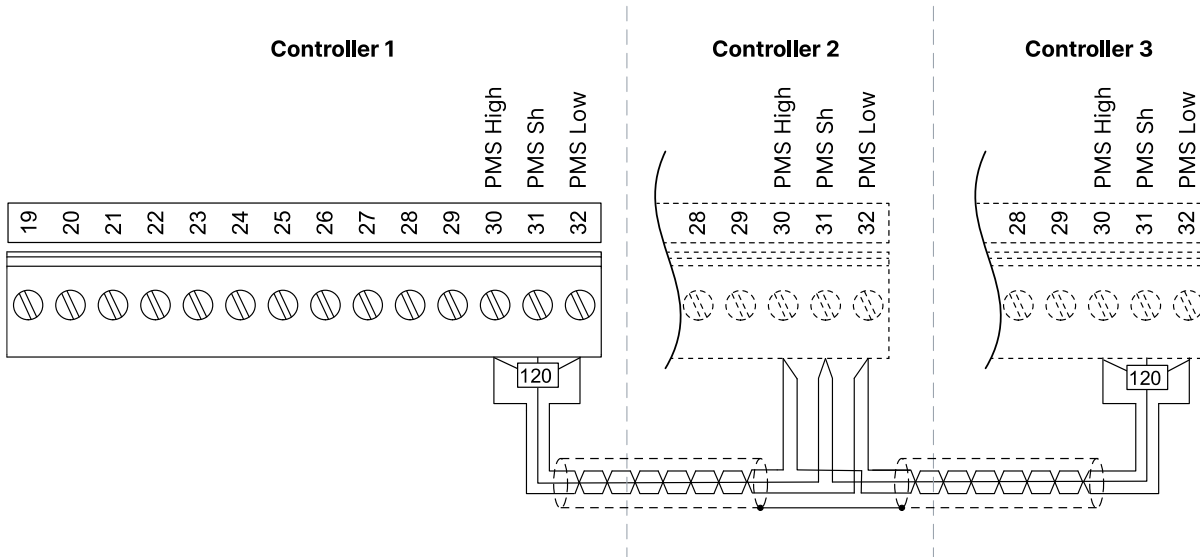

5.4.3 Third party digital load sharing

Use the CAN bus terminals to connect the AGC 150 controllers and third party controllers in series for digital load sharing.

Third party digital load sharing using CAN bus interfaces example

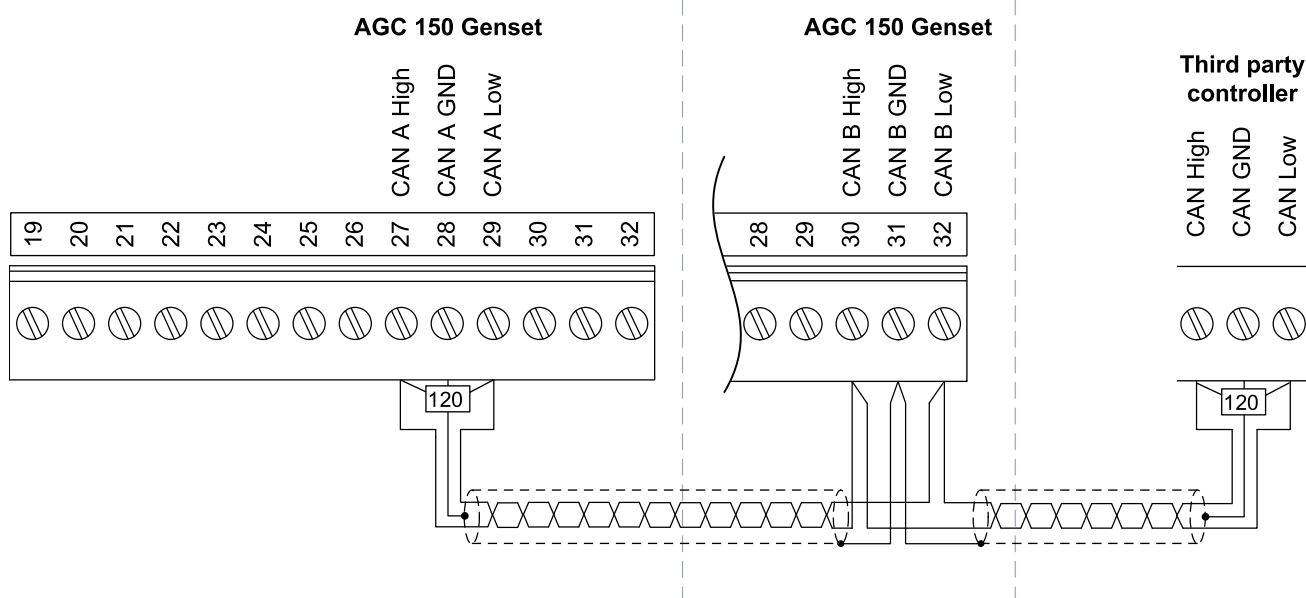

5.4.4 CAN bus engine communication

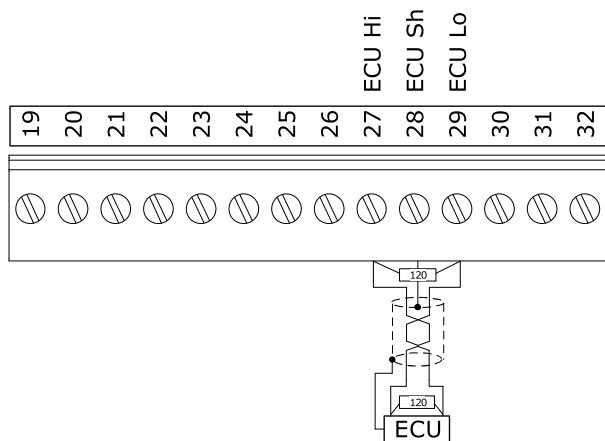

To be EN60255 compliant, when wiring is more than 10 m, terminal 28 must be connected to GND.

5.4.5 Modbus RS-485 (AGC/ASC is the server)

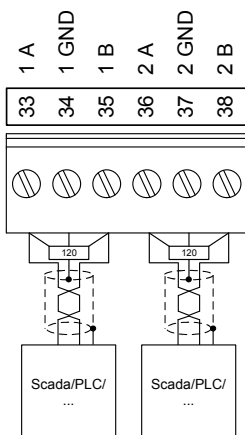

RS-485 port 1 has galvanic isolation, and RS-485 port 2 does not have galvanic isolation.

NOTE If there is no internal resistor across the *Scada/PLC/...* terminals, install an external 120 Ω resistor.

To be EN60255 compliant, when wiring is more than 10 m, terminals 34 and 37 must be connected to GND.

Multiple controllers connected to SCADA/PLC (2-wire)

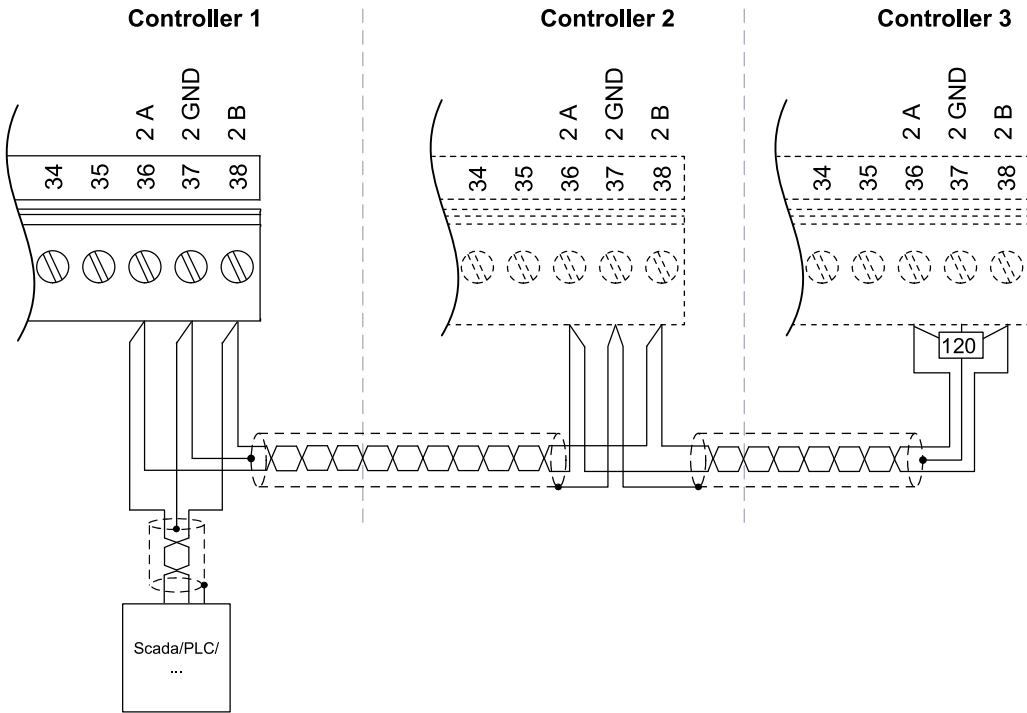

Multiple controllers connected to SCADA/PLC (3-wire)

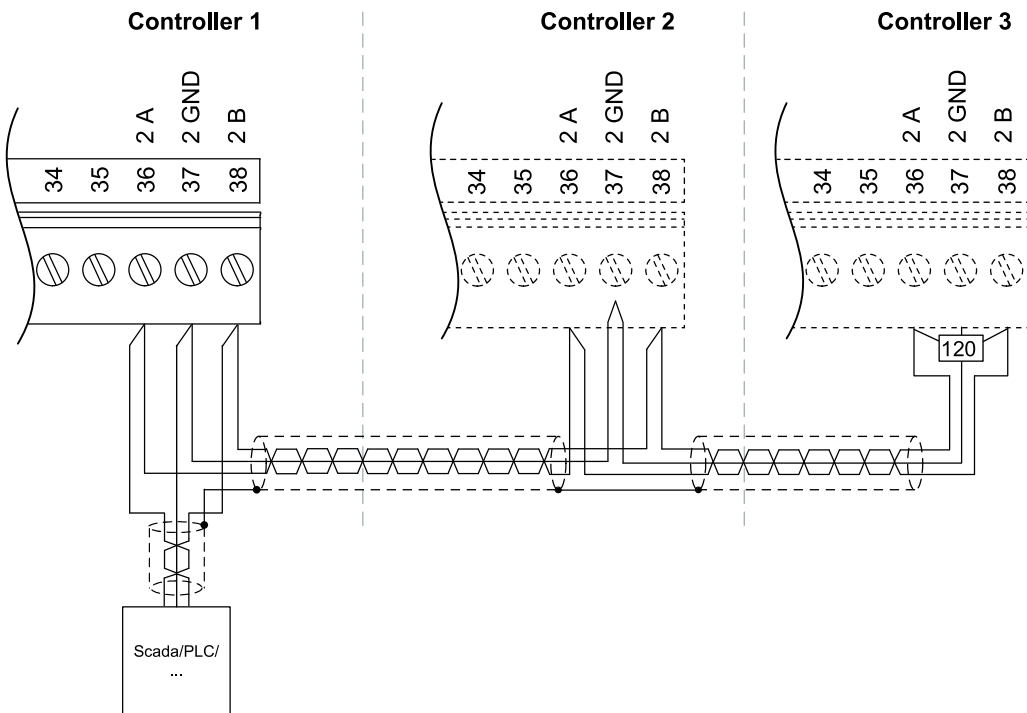

5.4.6 Modbus RS-485 (ASC is the client)

Power meter daisy chains

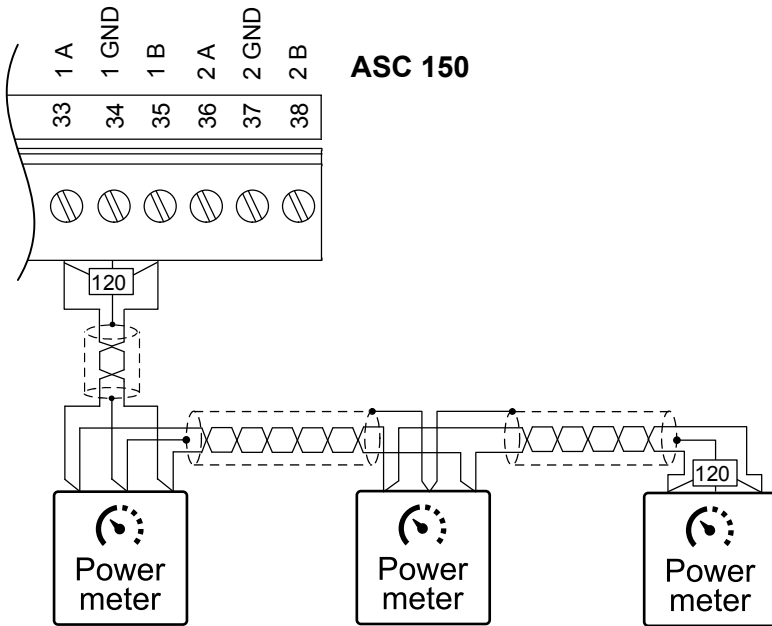

RS-485 port 1 has galvanic isolation, and RS-485 port 2 does not have galvanic isolation. Port 1 is recommended for communication with the power meters.

You can daisy chain power meters if they are the same type. You can include both genset* and mains power meters in the same daisy chain, even if they are different types.

To be EN60255 compliant, when wiring is more than 10 m, terminals 34 and 37 must be connected to GND.



More information

* An external genset controller can also act as a power meter. See **Power measurements** in the **DEIF hybrid compatibility** application note for the compatible power meters and genset controllers.