

AGC 150 Hybrid

PV, Genset and Mains controller

Data sheet



1. AGC 150 Hybrid

1.1 About	3
1.1.1 Software packages	3
1.2 Greenfield applications	4
1.2.1 Hybrid application with a genset, PV and mains	4
1.2.2 Off-grid hybrid application	4
1.3 Brownfield applications	5
1.3.1 Adding PV to an application with synchronising gensets	5
1.3.2 Adding PV to an application with a non-synchronising genset	5
1.3.3 Adding PV to an application with non-synchronising gensets	6
1.4 Display, buttons and LEDs	6
1.5 Typical wiring for hybrid controller	8
1.6 Functions and features	8
1.6.1 Solar functions	8
1.6.2 Genset functions	9
1.6.3 General controller functions	12
1.6.4 Supported photovoltaic systems	13
1.6.5 Supported controllers and engines	13
1.6.6 Exhaust after-treatment (Tier 4/Stage V)	13
1.6.7 Emulation	13
1.6.8 Easy configuration with the utility software	14
1.7 Protections overview	14

2. Compatible products

2.1 Remote monitoring service: Insight	16
2.2 Digital voltage controllers	16
2.3 Additional inputs and outputs	16
2.4 Additional operator panel, AOP-2	16
2.5 Remote display: AGC 150	16
2.6 Other equipment	16
2.7 Controller types	17

3. Technical specifications

3.1 Electrical specifications	18
3.2 Environmental specifications	21
3.3 UL/cUL Listed	22
3.4 Communication	22
3.5 Approvals	23
3.6 Dimensions and weight	23

4. Legal information

4.1 Software version	25
-----------------------------	-----------

1. AGC 150 Hybrid

1.1 About

The AGC 150 Hybrid controller is a flexible controller to protect and control gensets, up to 16 PV inverters, and a mains connection.

The controller has built-in AC measurements. There are two sets of voltage measurements (three phases, and (optional) the neutral phase), and one set of current measurements (three phases). There is also a 4th current measurement that can be used to measure mains power.

Operators can easily control the system from the display unit. Alternatively, use the communication options to connect to an HMI/SCADA system.

Greenfield and brownfield applications

The AGC 150 Hybrid controller is ideal for greenfield applications. One controller can provide flexible protection and control for a genset, the genset breaker, the inverters, the PV breaker, and a mains breaker.

The AGC 150 Hybrid controller can also be used to control PV power when this is added to an existing plant (brownfield applications).

Grid-tied

The AGC 150 Hybrid controller can feed surplus PV energy to the grid. Alternatively, the controller can regulate the PV production to match the self-consumption. This prevents any feed-in of PV power to the grid.

Off-grid

The AGC 150 Hybrid controller can combine PV power with genset power. It uses the genset power measurements to calculate the set points for the PV power.

1.1.1 Software packages

You can choose the **Stand-alone**, **Core**, **Extended** or **Premium** software package.

1.2 Greenfield applications

1.2.1 Hybrid application with a genset, PV and mains

One AGC 150 Hybrid controller can control an application with a single genset, PV, and mains. The AGC 150 regulates the genset governor and AVR. It also controls the PV breaker and the mains breaker. For the genset regulation, you can use the AGC 150 analogue outputs. Alternatively, regulate the governor and AVR using the ECU.

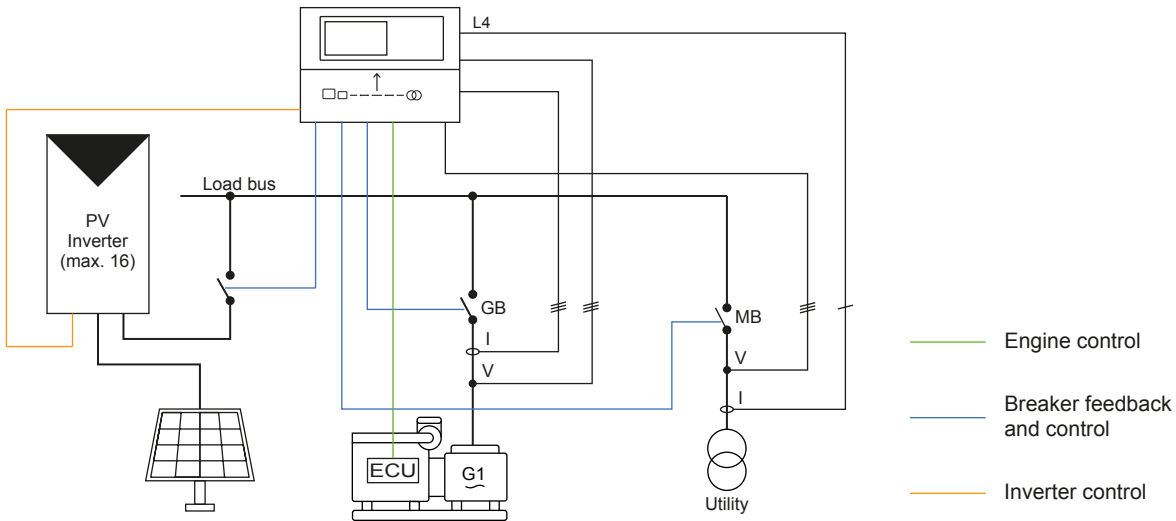

1.2.2 Off-grid hybrid application

The AGC 150 Hybrid controller can control an application that combines PV power with genset power. It calculates the power set points for the PV power based on the genset power measurements. This ensures that the minimum genset load requirement is met.

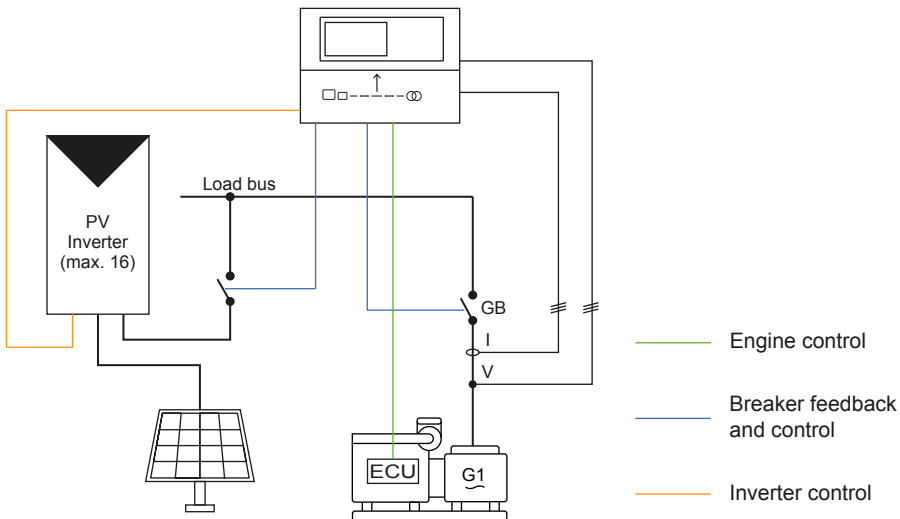

1.3 Brownfield applications

1.3.1 Adding PV to an application with synchronising gensets

When PV power is added to a power management system, the application can include up to two synchronising gensets. The power management system can be from any supplier. The power management system controls Genset 1 and 2, as well as the genset breakers. The AGC 150 Hybrid controller is not part of the power management system.

To control the photovoltaic power, three sets of nominal settings are used in the AGC 150 Hybrid controller. Different nominal settings are used in the AGC 150 Hybrid controller when both Genset 1 and 2, Genset 1, or Genset 2 are connected.

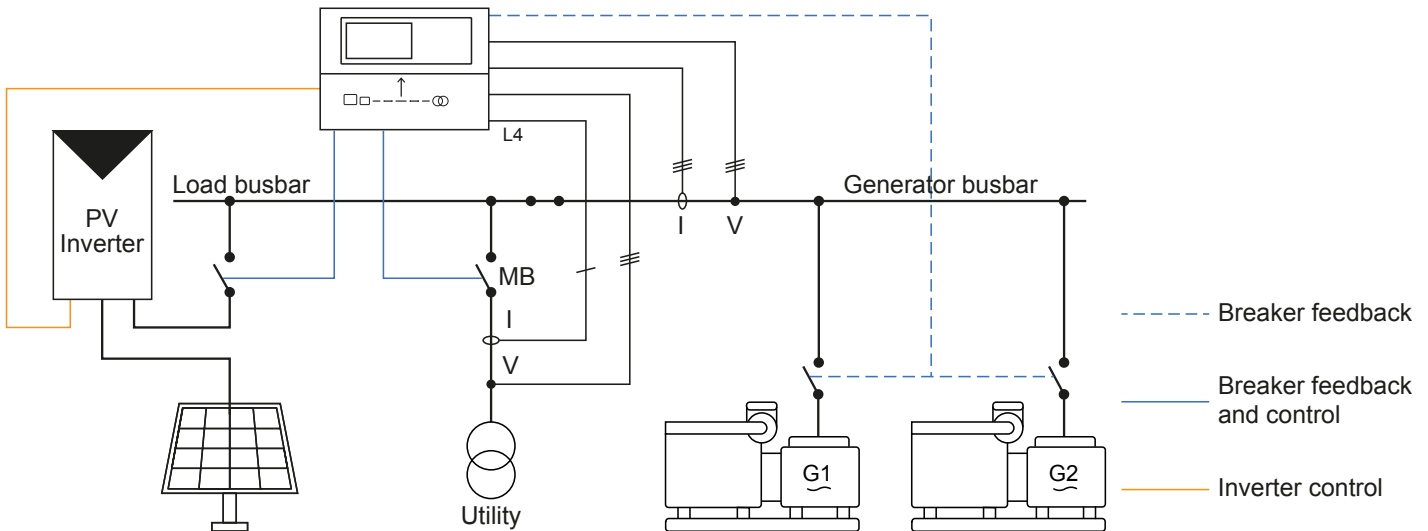

NOTE Alternatively, this application can have an externally controlled mains breaker.

1.3.2 Adding PV to an application with a non-synchronising genset

For an application with a single genset, PV, mains and ATS, one AGC 150 Hybrid controller can control the application. The AGC 150 regulates the genset governor and AVR. The AGC 150 controls the PV breaker, and the mains breaker*.

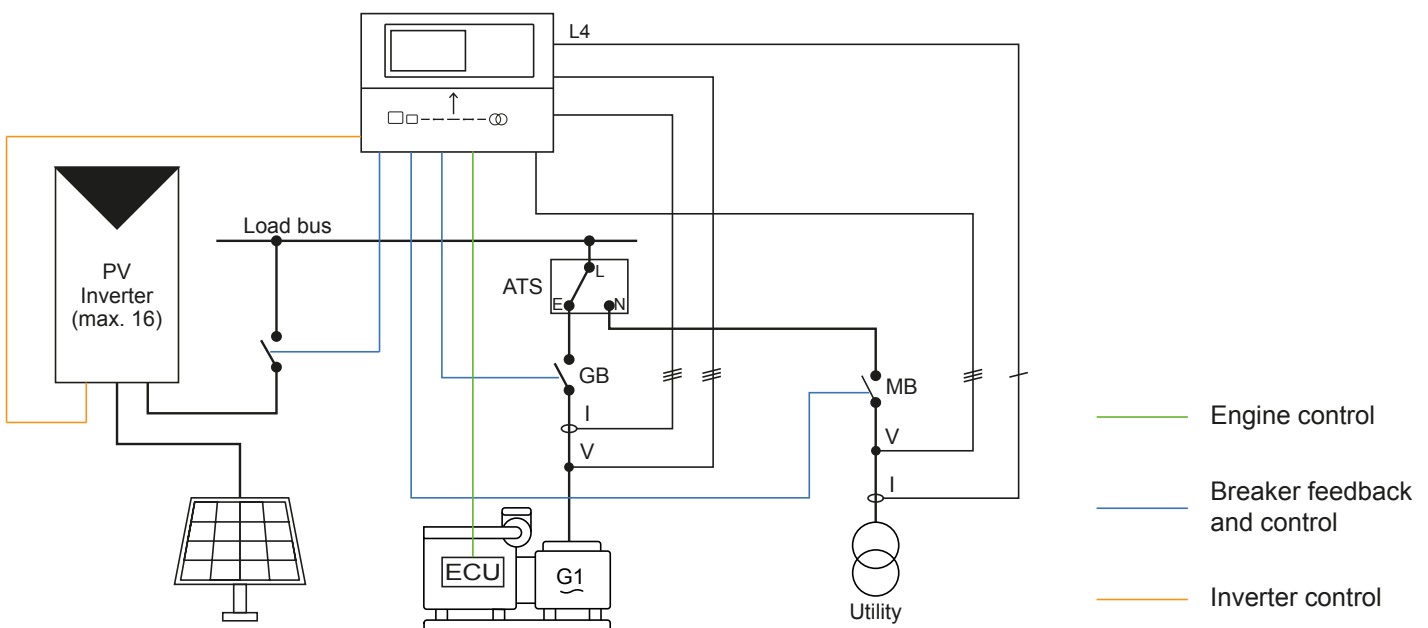

NOTE * Alternatively, this application can have an externally controlled mains breaker.

1.3.3 Adding PV to an application with non-synchronising gensets

By switching between four sets of nominal settings in the AGC 150s, the controller can adapt the minimum genset load to match the connected generator. You can have up to four non-sync generators.

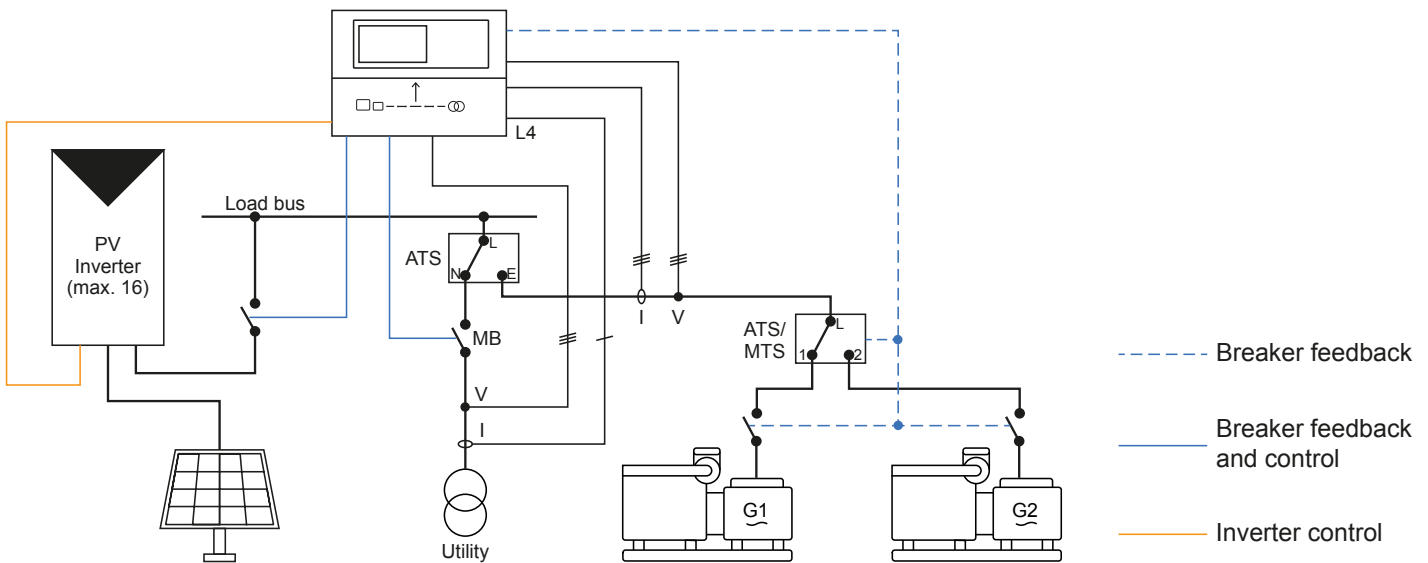

NOTE Use digital inputs and M-Logic for the feedback from the ATS and genset breakers.

NOTE Alternatively, this application can have an externally controlled mains breaker.

1.4 Display, buttons and LEDs

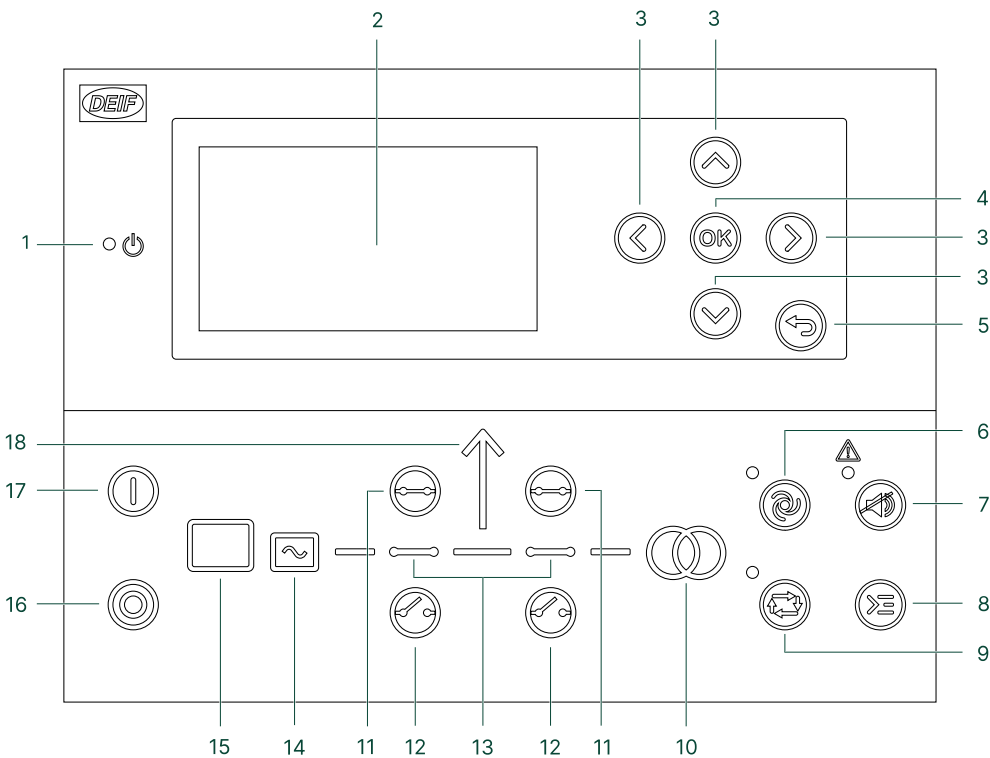

No.	Name	Function
1	Power	Green: The controller power is ON. OFF: The controller power is OFF.
2	Display screen*	Resolution: 240 x 128 px. Viewing area: 88.50 x 51.40 mm.

No.	Name	Function
		Six lines, each with 25 characters.
3	Navigation	Move the selector up, down, left and right on the screen.
4	OK	Go to the Menu system. Confirm the selection on the screen.
5	Back	Go to the previous page.
6	AUTO mode	The controller automatically starts and stops (and connects and disconnects) the genset. The controller also automatically connects and disconnects the PV and mains. No operator actions are needed.
7	Silence horn	Stops an alarm horn (if configured) and enters the Alarm menu.
8	Shortcut menu	Access the Jump menu, Mode selection, Test, Lamp test, and Hybrid (PV semi start and stop).
9	SEMI-AUTO mode	The operator or an external signal can start, stop, connect or disconnect the genset. The operator or an external signal can also open and close the other breakers (PV and mains). Automatic controller actions are not possible. The controller automatically synchronises before closing a breaker, and automatically de-loads before opening a breaker.
10	Mains symbol	Green: Mains voltage and frequency are OK. The controller can synchronise and close the breaker. Red: Mains failure.
11	Close breaker	Push to close the breaker.
12	Open breaker	Push to open the breaker.
13	Breaker symbols	Green: Breaker is closed. Green flashing: Synchronising or de-loading. Red: Breaker failure.
14	Generator	Green: Generator voltage and frequency are OK. The controller can synchronise and close the breaker. Green flashing: The generator voltage and frequency are OK, but the V&Hz OK timer is still running. The controller cannot close the breaker. Red: The generator voltage is too low to measure.
15	Engine	Green: There is running feedback. Green flashing: The engine is getting ready. Red: The engine is not running, or there is no running feedback.
16	Stop	Stops the genset if SEMI-AUTO or Manual is selected.
17	Start	Starts the genset if SEMI-AUTO or Manual is selected.
18	Load symbol	Green: The supply voltage and frequency are OK. Red: Supply voltage/frequency failure.

NOTE * You can use the display to monitor PV operation.

1.5 Typical wiring for hybrid controller

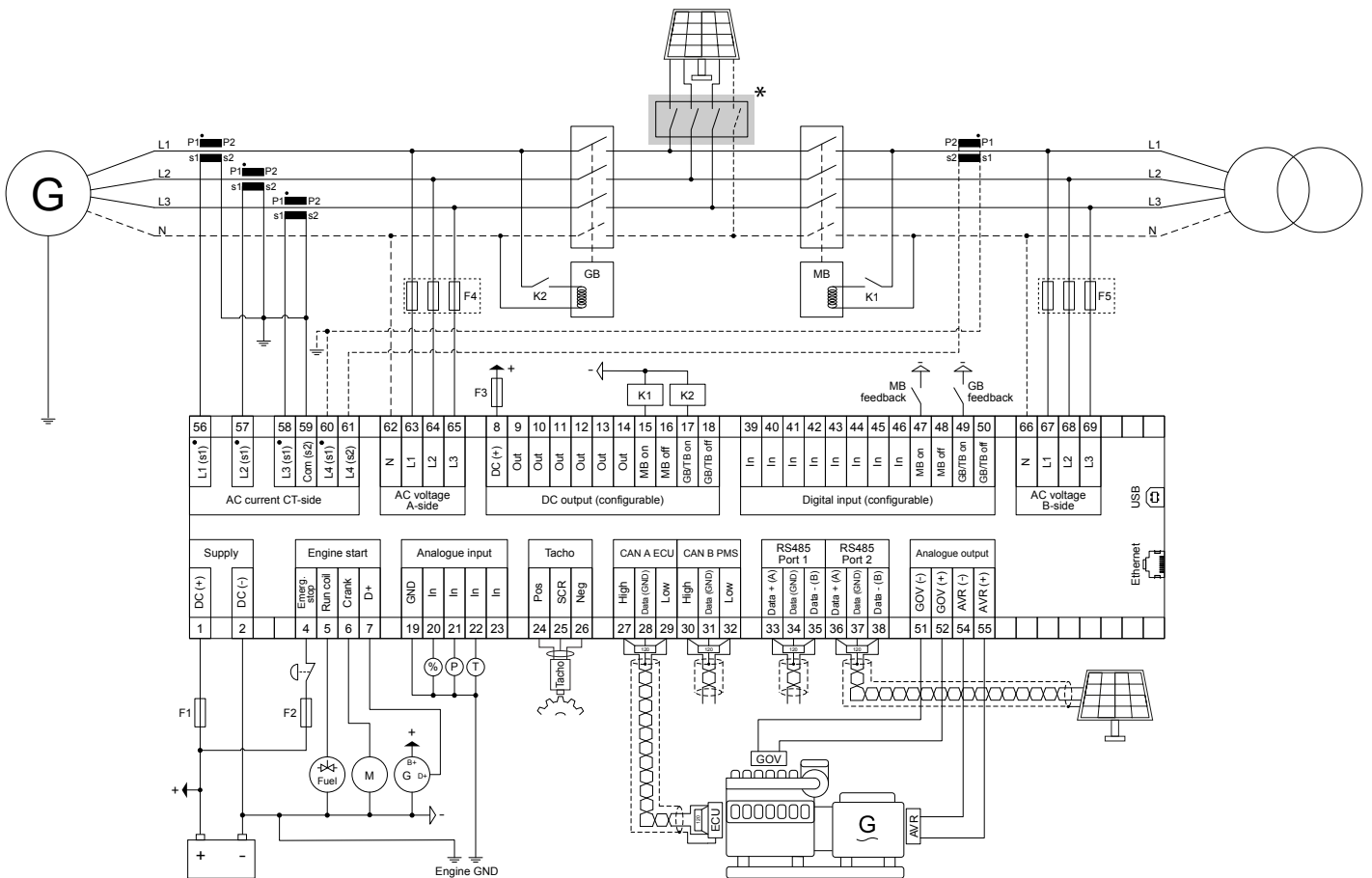

NOTE * Optional PV breaker.

Fuses

- F1: 2 A DC max. time-delay fuse/MCB, c-curve
- F2: 6 A AC max. time-delay fuse/MCB, c-curve
- F3: 4 A DC max. time-delay fuse/MCB, b-curve
- F4, F5: 2 A AC max. time-delay fuse/MCB, c-curve

1.6 Functions and features

1.6.1 Solar functions

Spinning reserve

If there is a mains connection, the AGC 150 Hybrid controller can start and stop the genset to provide a spinning reserve. The spinning reserve can be a percentage of the PV power production or the mains import.

Ideal for self-consumption applications

While in grid parallel mode, the AGC 150 Hybrid can feed surplus PV energy to the grid and generate profit in accordance with grid operator feed-in tariffs. Alternatively, the controller can regulate the PV production to match the self-consumption, thereby preventing any feed-in of PV power to the grid if prohibited by grid operator regulations.

Solar functions

- 16 inverters (TCP/IP or RTU communication)
- Inverters with TCP/IP communication:
 - Separate IP addresses and/or multiple inverters at the same node

Solar functions

- Select TCP or UDP
- Ensure a minimum genset load
- Irradiance sensor
- Solar power load calculation
- Reactive power control
- PV integration
- PV/diesel applications
- PV power counters (kWh)
- PV breaker feedback and control
- Inverter monitoring
- Inverter start/stop logic
- Weather station support



More information

For weather forecasts and/or redundant controllers (option T1), use an **ASC-4 Solar** controller.



More information

To control more than one genset, use **AGC 150 Genset** controllers. Similarly, to control more than one mains connection, use **AGC 150 Mains** controllers. For more than one PV system, use **ASC 150 Solar** controllers. To include energy storage, use **ASC 150 Storage** controllers. These controllers can work together in a power management system. Note however that the AGC 150 Hybrid controller cannot be used in this power management system.

1.6.2 Genset functions

Genset load management

In any operation mode, the AGC 150 Hybrid controller automatically maximises the sustainable power penetration (depending on the total load demand) while it makes sure that the genset(s) have the required minimum load. The minimum genset load prevents reverse power, impure combustion, and exhaust problems.

NOTE If the application has only one genset, the controller supports the following genset functions.

Generator functions

Synchronising functions	Stand-alone	Core	Extended
Non-synchronising	●		
Synchronising (dynamic)		●	●
Synchronising (static)			●
CBE (run up sync)			●
Short-time parallel		●	●

Generator functions	Stand-alone	Core	Extended
Built-in analogue AVR control		●	●
External analogue AVR control via IOM 230		●	●
Digital AVR control: Remote configuration, DVC - DEIF		●	●

Generator functions	Stand-alone	Core	Extended
Step-up transformer (with phase angle compensation)			●
Communication with KWG ISO5 isolation monitor (CAN bus)	●	●	●

Advanced AC protections	Stand-alone	Core	Extended
Vector jump			●
df/dt (ROCOF)			●
Under-voltage and reactive power, U and Q			●
Average busbar over-voltage			●
AC directional over-current protection			●
Negative sequence current (ANSI 46)			●
Negative sequence voltage (ANSI 47)			●
Zero sequence current (ANSI 51 I0)			●
Zero sequence voltage (ANSI 59 U0)			●
Power-dependent reactive power (ANSI 40)			●
Inverse time over-current (ANSI 51)			●
Grid support (frequency-dependent droop)			
Ground relay			●

4th current transformer measurement	Stand-alone	Core	Extended
High current alarms	2	2	2
High reverse alarms	2	2	2
High power alarms	2	2	2

Operation modes	Stand-alone	Core	Extended
Island mode	●	●	●
AMF mode	●	●	●
Load take-over	●	●	●
Fixed power	*	●	●
Mains power export	*	●	●
Peak shaving		●	●
Ventilation	●	●	●
Dry alternator	●	●	●

NOTE * When only PV is connected to the mains.

Load sharing	Stand-alone	Core	Extended
Analogue load sharing (with IOM 230)		●	●
Digital load sharing (CANshare)		●	●

Engine functions

Start and stop functions	Stand-alone	Core	Extended
Start and stop sequences	●	●	●
Temperature-dependent cooling down	●	●	●
Time-based cooling down	●	●	●
Configurable crank and run coil	●	●	●

Regulation functions	Stand-alone	Core	Extended
Governor regulation using: <ul style="list-style-type: none"> • Engine communication • Built-in analogue control • External analogue control using IOM 230 • Relays 		● ● ● ●	● ● ● ●
Manual speed control using: <ul style="list-style-type: none"> • Digital inputs • Display screen menu (by the operator) • Analogue input • Modbus • Configured set point 		● ● ● ● ●	● ● ● ● ●
Speed sensing using CAN, MPU or frequency	●	●	●
Derate engine			●
Ventilation fan control			●
Power ramp up and down		●	●

Engine protections	Alarms	ANSI	Operate time
Overspeed	2	12	<400 ms
Crank failure	1	48	
Running feedback error	1	34	
MPU wire break	1	-	
Start failure	1	48	
Stop failure	1	48	
Stop coil, wire break alarm	1	5	
Engine heater	1	26	
Max. ventilation/radiator fan	1	-	
Fuel fill check	1	-	
Maintenance alarms	Multiple		

Other engine functions	Stand-alone	Core	Extended
Fuel usage monitoring	●	●	●
Fuel pump logic and refill	●	●	●
Diesel exhaust fluid monitoring	●	●	●
Diesel exhaust fluid logic and refill	●	●	●
Generic fluid monitoring	●	●	●
Generic fluid logic and refill	●	●	●

1.6.3 General controller functions

AC functions	Stand-alone	Core	Extended
Sets of nominal settings	4	4	4
Select the AC configuration:			
• 3-phase/3-wire	●	●	●
• 3-phase/4-wire	●	●	●
• 2-phase/3wire (L1/L2/N or L1/L3/N)	●	●	●
• 1-phase/2-wire L1	●	●	●
100 to 690 V AC (selectable)	●	●	●
CT -/1 or -/5 (selectable)	●	●	●
4th current measurement (select one)			
• Mains current (and power)	●	●	●
• Neutral current (1 × true RMS)	●	●	●
• Ground current (with 3rd harmonic filter)	●	●	●

General functions	Stand-alone	Core	Extended
Emulation for testing and front load commissioning		●	●
Built-in test sequences (Simple test, Load test, Full test, and Battery test)	●	●	●
PLC logic (M-Logic)	20 lines	20 lines	40 lines
Counters, including:			
• Breaker operations	●	●	●
• kWh meter (day, week, month, total)	●	●	●
• kvarh meter (day, week, month, total)	●	●	●
General purpose PID regulators (2 x built-in analogue outputs)			
4 additional analogue outputs (using 2 x IOM 230)			
Simple load shedding and adding			●
Changeable controller type			●

Setting and parameter functions	Stand-alone	Core	Extended
Quick setup		●	●
User permission level	●	●	●
Password-protected setup	●	●	●
Trending on USW	●	●	●
Event logs with password, up to 500 entries	●	●	●

Display and language functions	Stand-alone	Core	Extended
Supports multiple languages (including Chinese, Russian, and other languages with special characters)	●	●	●
20 configurable graphical screens	●	●	●
Graphical display with six lines	●	●	●
Parameters can be changed on the display unit	●	●	●
3 engine function shortcuts	●	●	●

Display and language functions	Stand-alone	Core	Extended
20 configurable shortcut buttons	●	●	●
5 configurable display screen "LED lamps" (on/off/blink)	●	●	●

Modbus functions	Stand-alone	Core	Extended
Modbus RS-485	●	●	●
Modbus TCP/IP	●	●	●
Configurable Modbus area	●	●	●

1.6.4 Supported photovoltaic systems

DEIF hybrid controllers are compatible with photovoltaic (PV) systems from a wide range of manufacturers.

SunSpec compliance

All DEIF hybrid controllers are compliant with the SunSpec standards (see sunspec.org). DEIF controllers are therefore compatible with new inverters that use the generic SunSpec protocol.

Testing

Many PV inverter makers use the same protocol for a wide range of their products. New PV inverters often comply with the older protocol. If a specific inverter is not listed, but the maker is listed, there is a good chance that the DEIF controller is compatible.

If your PV inverter is not listed, DEIF can help to confirm compliance using the Modbus protocol documentation.

Implementing new protocols

Since new PV systems are launched every year, DEIF developers continuously implement new protocols. If your system is not listed, please contact DEIF. We can work with you to quickly implement the required protocol.



More information

See **Application note, DEIF hybrid controller compatibility** for the list of the supported protocols.

1.6.5 Supported controllers and engines

The AGC supports J1939 and can communicate with any engine that uses generic J1939. In addition, the AGC can communicate with a wide range of ECUs and engines.



More information

See **Engine communication AGC 150** for a full list of supported ECUs and engines, along with detailed information for each protocol.

1.6.6 Exhaust after-treatment (Tier 4/Stage V)

AGC 150 supports Tier 4 (Final)/Stage V requirements. It provides monitoring and control of the exhaust after-treatment system, as required by the standard.



More information

See the **AGC 150 Operator's manual** for more information.

1.6.7 Emulation

AGC 150 includes an emulation tool to verify and test the functionality of the application, for example plant modes and logics, breaker handling, mains and generator operation.

Application emulation is useful for training, customising plant requirements and for testing basic functionality that needs to be set up or verified.

1.6.8 Easy configuration with the utility software

Set up an application easily with a PC and the utility software.

You can also use the utility software to quickly configure the inputs, outputs, and parameters.

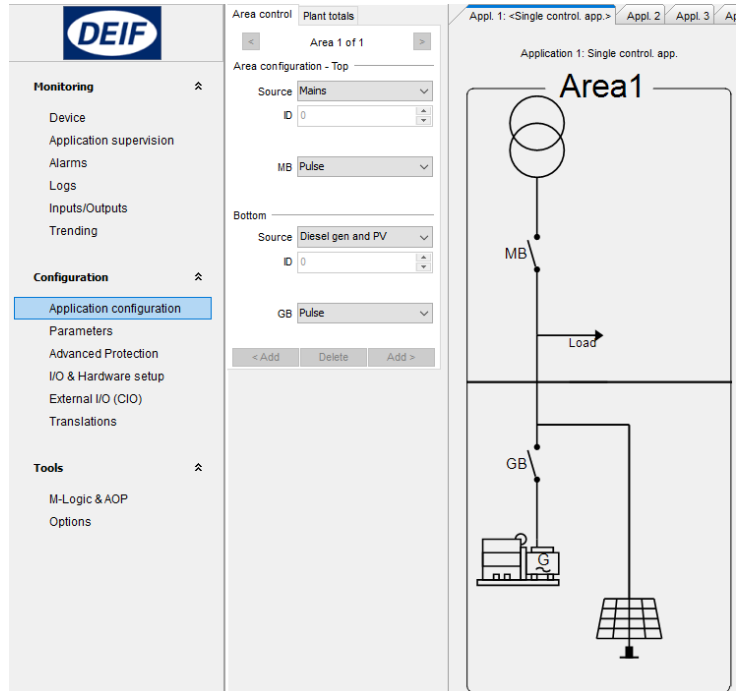

1.7 Protections overview

Protections	Alarms	ANSI	Operate time
Reverse power	2	32R	<200 ms
Fast over-current	2	50P	<40 ms
Over-current	4	50TD	<200 ms
Voltage dependent over-current	1	51V	
Over-voltage	2	59	<200 ms
Under-voltage	3	27P	<200 ms
Over-frequency	3	81O	<300 ms
Under-frequency	3	81U	<300 ms
Unbalanced voltage	1	47	<200 ms
Unbalanced current	1	46	<200 ms
Under-excitation or reactive power import	1	32RV	<200 ms
Over-excitation or reactive power export	1	32FV	<200 ms
Overload	5	32F	<200 ms
Earth current	1	51G	<100 ms
Neutral current	1	51N	<100 ms
Busbar/mains over-voltage	3	59P	<50 ms
Busbar/mains under-voltage	4	27P	<50 ms
Busbar/mains over-frequency	3	81O	<50 ms

Protections	Alarms	ANSI	Operate time
Busbar/mains under-frequency	3	81U	<50 ms
Emergency stop	1	1	<200 ms
Low auxiliary supply	1	27DC	
High auxiliary supply	1	59DC	
Generator breaker external trip	1	5	
Mains breaker external trip	1	5	
Synchronisation failure alarms	1/breaker	25	
Breaker open failure	1/breaker	52BF	
Breaker close failure	1/breaker	52BF	
Breaker position failure	1/breaker	52BF	
Close before excitation failure	1	48	
Phase sequence error	1	47	
De-load error	1	34	
Hz/V failure	1	53	
Not in Auto	1	34	
Vector jump	1	78	<40 ms
df/dt (ROCOF)	1	81R	<130 ms
Under-voltage and reactive power, U and Q	2		<250 ms
Positive sequence (mains) voltage low	1	27	<60 ms
Directional over-current	2	67	<100 ms
Negative sequence voltage high	1	47	<400 ms
Negative sequence current high	1	46	<400 ms
Zero sequence voltage high	1	59U0	<400 ms
Zero sequence current high	1	50G	<400 ms
Power-dependent reactive power	1	40	-
IEC/IEEE inverse time over-current	1	51	-

NOTE See [Genset functions](#) for engine protections.

2. Compatible products

2.1 Remote monitoring service: Insight

Insight is a responsive remote monitoring service. It includes real-time genset data, a customisable dashboard, GPS tracking, equipment and user management, email and/or SMS alerts, and cloud data management. See www.deif.com/products/insight

2.2 Digital voltage controllers

DVC 350 is a digital AVR designed for alternators with SHUNT, AREP or PMG excitation. The DVC 350 monitors and regulates the alternator output voltage. AGC 150 can control the DVC 350 features and receive fault information directly with the CAN bus communication. For more information, see www.deif.com/products/dvc-350

DVC 550 is an advanced digital AVR designed for alternators with SHUNT, AREP or PMG excitation. The DVC 550 monitors and regulates the alternator output voltage. AGC 150 can control all the DVC 550 features and receive fault information directly with the CAN bus communication. For more information, see www.deif.com/products/dvc-550

2.3 Additional inputs and outputs

AGC 150 uses CAN bus communication with these:

- **CIO 116** is a remote input expansion module. See www.deif.com/products/cio-116
- **CIO 208** is a remote output expansion module. See www.deif.com/products/cio-208
- **CIO 308** is a remote I/O module. See www.deif.com/products/cio-308
- **IOM 220** and **IOM 230** each have two analogue outputs. These can be used for governor and AVR regulation, or general PID control.

2.4 Additional operator panel, AOP-2

The controller uses CAN bus communication to the additional operator panel (AOP-2). Configure the controller using M-Logic. On the AOP-2, the operator can then:

- Use the buttons to send commands to the controller.
- See LEDs light up to show statuses and/or alarms.

You can configure and connect two AOP-2s if the controller has the premium software package.

2.5 Remote display: AGC 150

The remote display is an AGC 150 that only has a power supply and an Ethernet connection to an AGC 150 controller. The remote display allows the operator to see the controller's operating data, as well as operate the controller remotely.

See www.deif.com/products/agc-150-remote-display

2.6 Other equipment

DEIF has a wide variety of other equipment that is compatible. Here are some examples:

- **Synchrosopes**
 - **CSQ-3** (www.deif.com/products/csq-3)
- **Battery chargers/power supplies**
 - **DBC-1** (www.deif.com/products/dbc-1)
- **Current transformers**

- **ASK** (www.deif.com/products/ask-asr)
- **KBU** (www.deif.com/products/kbu)
- **Transducers**
 - **MTR-4** (www.deif.com/products/mtr-4)

2.7 Controller types

If the AGC 150 or ASC 150 has an extended or premium software package, you can change it to any AGC 150 or ASC 150* controller type. Select the controller type under `Basic settings > Controller settings > Type`.

Parameter	Setting	Controller type
9101	DG unit	Genset (Generator or Stand-alone) controller
	Mains unit	Mains controller
	BTB unit	BTB controller
	DG HYBRID unit	Genset-Solar hybrid controller
	ENGINE DRIVE unit	Engine drive controller
	Remote unit	Remote display
	ENGINE DRIVE MARINE unit	Engine drive controller for marine use
	DG MARINE unit	Stand-alone genset controller for marine use
	ASC 150 Storage*	Battery storage controller
	ASC 150 Solar*	Solar controller
	ATS unit	Automatic transfer switch
	DG PMS Lite	PMS Lite controller

NOTE * To change to these controller types, the controllers must have the sustainability option (S10).

3. Technical specifications

3.1 Electrical specifications

Power supply	
Power supply range	Nominal voltage: 12 V DC or 24 V DC Operating range: 6.5 to 36 V DC
Voltage withstand	Reverse polarity
Power supply drop-out immunity	0 V DC for 50 ms (coming from min. 6 V DC)
Power supply load dump protection	Load dump protected according to ISO16750-2 test A
Power consumption	5 W typical 12 W max.
RTC clock	Time and date backup

Supply voltage monitoring	
Measuring range	0 V to 36 V DC Max. continuous operating voltage: 36 V DC
Resolution	0.1 V
Accuracy	±0.35 V

Voltage measurement	
Voltage range	Nominal range: 100 to 690 V phase-to-phase (above 2000 m derate to max. 480 V)
Voltage withstand	$U_n + 35\%$ continuously, $U_n + 45\%$ for 10 seconds Measuring range of nominal: 10 to 135 % Low range, nominal 100 to 260 V: 10 to 351 V AC phase-to-phase High range, nominal 261 to 690 V: 26 to 932 V AC phase-to-phase
Voltage accuracy	±1 % of nominal within 10 to 75 Hz +1/-4 % of nominal within 3.5 to 10 Hz
Frequency range	3.5 to 75 Hz
Frequency accuracy	±0.01 Hz within 60 to 135 % of nominal voltage ±0.05 Hz within 10 to 60 % of nominal voltage
Input impedance	4 MΩ/phase-to-ground, and 600 kΩ phase/neutral

Current measurement	
Current range	Nominal: -/1 A and -/5 A Range: 2 to 300 %
Number of CT input	4
Max. measured current	3 A (-/1 A) 15 A (-/5 A)
Current withstand	7 A continuous 20 A for 10 seconds 40 A for 1 second
Current accuracy	From 10 to 75 Hz: <ul style="list-style-type: none">±1 % of nominal from 2 to 100% current±1 % of measured current from 100 to 300 % current

Current measurement

	From 3.5 to 10 Hz: <ul style="list-style-type: none">+1/-4 % of nominal from 2 to 100 % current+1/-4 % of measured current from 100 to 300 % current
Burden	Max. 0.5 VA

Power measurement

Accuracy power	±1 % of nominal within 35 to 75 Hz
Accuracy power factor	±1 % of nominal within 35 to 75 Hz

D+

Excitation current	210 mA, 12 V 105 mA, 24 V
Charging fail threshold	6 V

Tacho input

Voltage input range	+/- 1 V _{peak} to 70 V _{peak}
W	8 to 36 V
Frequency input range	10 to 10 kHz (max.)
Frequency measurement tolerance	1 % of reading

Digital inputs

Number of inputs	12 x digital inputs Negative switching
Maximum input voltage	+36 V DC with respect to plant supply negative
Minimum input voltage	-24 V DC with respect to plant supply negative
Current source (contact cleaning)	Initial 10 mA, continuous 2 mA

DC outputs

Number of 3 A outputs	2 x outputs (for fuel and crank) 15 A DC inrush and 3 A continuous, supply voltage 0 to 36 V DC Endurance tested according to UL/ULC6200:2019 1.ed: 24 V, 3 A, 100000 cycles (with an external freewheeling diode)
Number of 0.5 A outputs	10 x outputs 2 A DC inrush and 0.5 A continuous, supply voltage 4.5 to 36 V DC
Common	12/24 V DC

Analogue inputs

Number of inputs	4 x analogue inputs
Electrical range	Configurable as: <ul style="list-style-type: none">Negative switching digital input0 V to 10 V sensor4 mA to 20 mA sensor0 Ω to 2.5 kΩ sensor
Accuracy	Current:

Analogue inputs

- Accuracy: $\pm 20 \mu\text{A} \pm 1.00 \% \text{ rdg}$
- Voltage:
- Range: 0 to 10 V DC
 - Accuracy: $\pm 20 \text{ mV} \pm 1.00 \% \text{ rdg}$
- RMI 2-wire LOW:
- Range: 0 to 800 Ω
 - Accuracy: $\pm 2 \Omega \pm 1.00 \% \text{ rdg}$
- RMI 2-wire HIGH:
- Range: 0 to 2500 Ω
 - Accuracy: $\pm 5 \Omega \pm 1.00 \% \text{ rdg}$

Voltage regulator output

Output types	Isolated DC voltage output
Voltage range	-10 to +10 V DC
Resolution in voltage mode	Less than 1 mV
Maximum common mode voltage	$\pm 3 \text{ kV}$
Minimum load in voltage mode	500 Ω
Accuracy	$\pm 1 \% \text{ of setting value}$

Speed governor output

Output types	Isolated DC voltage output Isolated PWM output
Voltage range	-10 to +10 V DC
Resolution in voltage mode	Less than 1 mV
Maximum common mode voltage	$\pm 550 \text{ V}$
Minimum load in voltage mode	500 Ω
PWM frequency range	1 to 2500 Hz $\pm 25 \text{ Hz}$
PWM duty cycle resolution (0-100%)	12 bits (4096 steps)
PWM voltage range	1 to 10.5 V
Voltage accuracy	$\pm 1\% \text{ of setting value}$

Display unit

Type	Graphical display screen (monochrome)
Resolution	240 x 128 pixels
Navigation	Five-key menu navigation
Log book	Data log and trending function
Language	Multi-language display

3.2 Environmental specifications

Operation conditions	
Operating temperature (incl. display screen)	-40 to +70 °C (-40 to +158 °F)
Storage temperature (incl. display screen)	-40 to +85 °C (-40 to +185 °F)
Accuracy and temperature	Temperature coefficient: 0.2 % of full scale per 10 °C
Operating altitude	0 to 4000 m with derating
Operating humidity	Damp Heat Cyclic, 20/55 °C at 97 % relative humidity, 144 hours. To IEC 60255-1 Damp Heat Steady State, 40 °C at 93 % relative humidity, 240 hours. To IEC 60255-1
Change of temperature	70 to -40 °C, 1 °C / minute, 5 cycles. To IEC 60255-1
Protection degree	IEC/EN 60529 <ul style="list-style-type: none"> • IP65 (front of module when installed into the control panel with the supplied sealing gasket) • IP20 on terminal side
Vibration	Response: <ul style="list-style-type: none"> • 10 to 58.1 Hz, 0.15 mmpp • 58.1 to 150 Hz, 1 g. To IEC 60255-21-1 (Class 2) Endurance: <ul style="list-style-type: none"> • 10 to 150 Hz, 2 g. To IEC 60255-21-1 (Class 2) Seismic vibration: <ul style="list-style-type: none"> • 3 to 8.15 Hz, 15 mmpp • 8.15 to 35 Hz, 2 g. To IEC 60255-21-3 (Class 2)
Shock	10 g, 11 ms, half sine. To IEC 60255-21-2 Response (Class 2) 30 g, 11 ms, half sine. To IEC 60255-21-2 Withstand (Class 2) 50 g, 11 ms, half sine. To IEC 60068-2-27, test Ea Tested with three impacts in each direction in three axes (total of 18 impacts per test)
Bump	20 g, 16 ms, half sine IEC 60255-21-2 (Class 2) Tested with 1000 impacts in each direction on three axes (total of 6000 impacts per test)
Galvanic separation	CAN port 2: 550 V, 50 Hz, 1 minute RS-485 port 1: 550 V, 50 Hz, 1 minute Ethernet: 550 V, 50 Hz, 1 minute Analogue output 51-52 (GOV): 550 V, 50 Hz, 1 minute Analogue output 54-55 (AVR): 3000 V, 50 Hz, 1 minute Note: No galvanic separation on CAN port 1 and RS-485 port 2
Safety	Installation CAT. III 600 V Pollution degree 2 IEC/EN 60255-27
Flammability	All plastic parts are self-extinguishing to UL94-V0
EMC	IEC/EN 60255-26

3.3 UL/cUL Listed

Requirements	
Installation	To be installed in accordance with the NEC (US) or the CEC (Canada)
Enclosure	A suitable type 1 (flat surface) enclosure is required Unventilated/ventilated with filters for controlled/pollution degree 2 environment
Mounting	Flat surface mounting
Connections	Use 90 °C copper conductors only
Wire size	AWG 30-12
Terminals	Tightening torque: 5-7 lb-in.
Current transformers	Use Listed or Recognized isolating current transformers
Communication circuits	Only connect to communication circuits of a listed system/equipment

3.4 Communication

Communication	
CAN A	<p>CAN port You can connect these in a daisy chain (and operate them at the same time):</p> <ul style="list-style-type: none"> • Engine CAN Port • DVC 550 • CIO 116, CIO 208, and CIO 308 • IOM 220 and IOM 230 <p>Data connection 2 wire + common Not isolated External termination required (120 Ω + matching cable) DEIF engine specification (J1939 + CANopen)</p>
CAN B	<p>CAN port Used for:</p> <ul style="list-style-type: none"> • AOP-2 <p>Data connection 2 wire + common Isolated External termination required (120 Ω + matching cable) PMS 125 kbit and 250 kbit</p>
RS-485 Port 1	<p>Used for:</p> <ul style="list-style-type: none"> • Modbus master to PV • Modbus master to weather station • Modbus RTU, PLC, SCADA, Remote monitoring (Insight) <p>Data connection 2-wire + common Isolated External termination required (120 Ω + matching cable) 9600 to 115200</p>
RS-485 Port 2	<p>Used for:</p> <ul style="list-style-type: none"> • Modbus master to PV • Modbus master to weather station • Modbus RTU, PLC, SCADA, Remote monitoring (Insight) <p>Data connection 2-wire + common Not isolated External termination required (120 Ω + matching cable) 9600 to 115200</p>

Communication

RJ45 Ethernet	<p>Used for:</p> <ul style="list-style-type: none"> • Modbus master to PV • Modbus master to weather station • Modbus to PLC, SCADA, and so on • NTP time synchronisation with NTP servers <p>Isolated Auto detecting 10/100 Mbit Ethernet port</p>
USB	Service port (USB-B)

3.5 Approvals

Standards

CE

UL/cUL Listed to UL/ULC6200:2019, 1. ed. controls for stationary engine gensets

NOTE Refer to www.deif.com for the most recent approvals.

3.6 Dimensions and weight

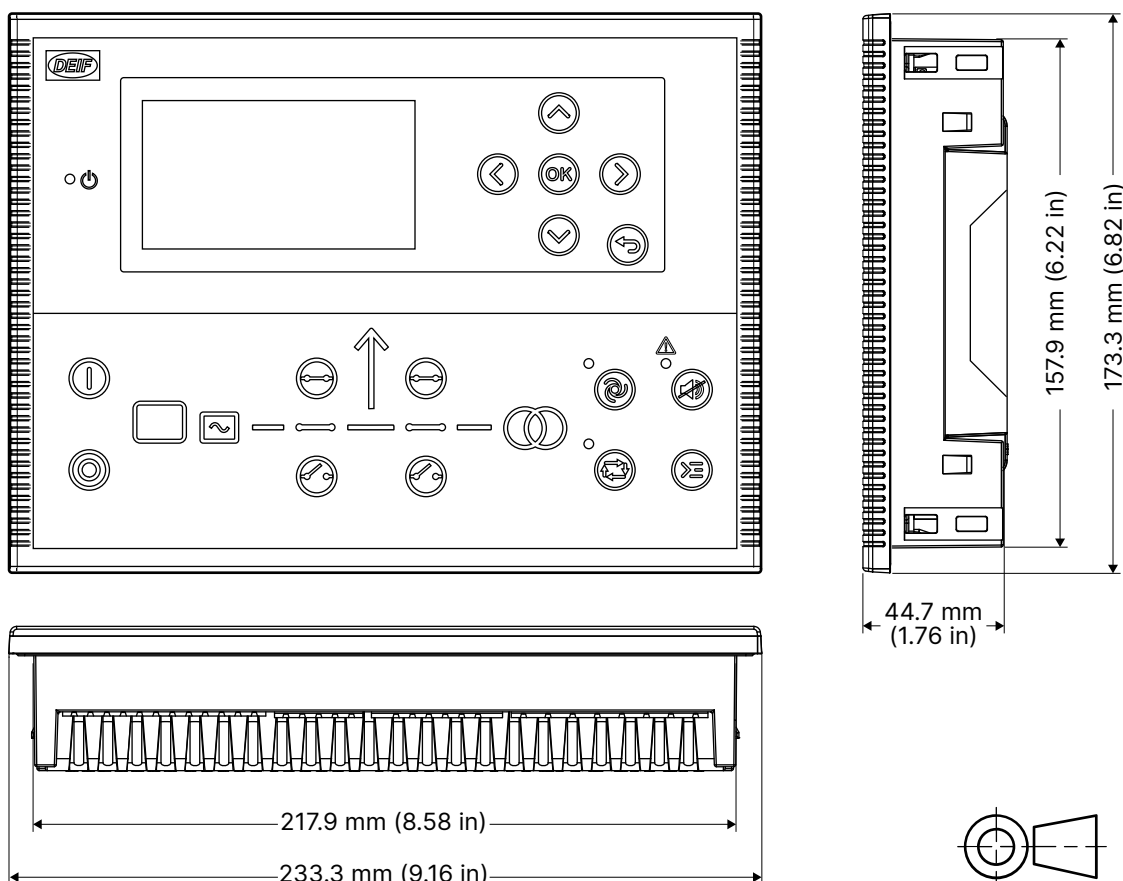

Dimensions and weight

Dimensions	<p>Length: 233.3 mm (9.16 in)</p> <p>Height: 173.3 mm (6.82 in)</p> <p>Depth: 44.7 mm (1.76 in)</p>
Panel cutout	Length: 218.5 mm (8.60 in)

Dimensions and weight

	Height: 158.5 mm (6.24 in) Tolerance: ± 0.3 mm (0.01 in)
Max. panel thickness	4.5 mm (0.18 in)
Mounting	UL/cUL Listed: Type complete device, open type 1 UL/cUL Listed: For use on a flat surface of a type 1 enclosure
Weight	0.79 kg

4. Legal information

Disclaimer

DEIF A/S reserves the right to change any of the contents of this document without prior notice.

The English version of this document always contains the most recent and up-to-date information about the product. DEIF does not take responsibility for the accuracy of translations, and translations might not be updated at the same time as the English document. If there is a discrepancy, the English version prevails.

Copyright

© Copyright DEIF A/S. All rights reserved.

4.1 Software version

This document is based on AGC 150 software version 1.17.