

SGC 420 Mk II

Single Genset Controller

Data sheet

4921240650-E

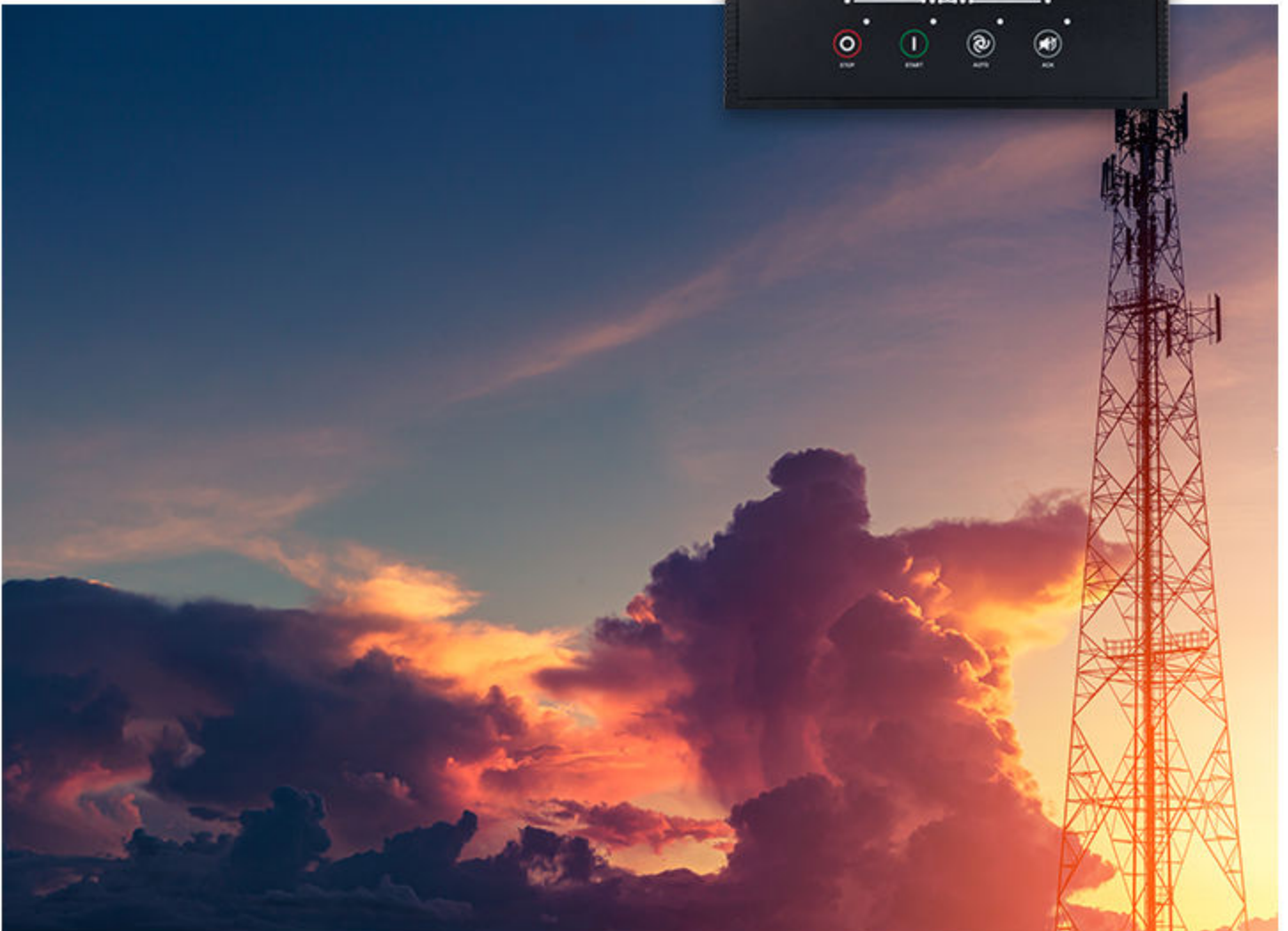

1. SGC 420 Mk II

1.1 About.....	3
1.1.1 Software version.....	3
1.2 Display, buttons, and LEDs.....	3
1.3 Protections overview.....	4
1.4 Functions.....	5
1.5 Single-line application diagrams.....	8

2. Technical specifications

2.1 Electrical specifications.....	11
2.2 Environmental specifications.....	14
2.3 Terminals.....	15
2.4 Approvals.....	17
2.5 Dimensions and weight.....	18

3. Legal information

1. SGC 420 Mk II

1.1 About

The SGC 420 Mk II controller has all the functions needed to protect and control a genset, a genset breaker, and a mains breaker. The values and alarms are shown on the LCD display screen, and operators can easily control the system from the display.

You can use the SGC 420 Mk II to monitor the site battery and significantly reduce your fuel consumption. The controller can also monitor shelter temperature, engine and alternator parameters, and the true RMS voltage and current.

Use the Smart Connect Mk II software to configure parameters, log data, add custom sensor curves, and supervise live data. M-Logic is also available from the software, which allows you to create functions using pre-defined events and outputs. The analogue comparator can be used to create custom alarms and logic functions.

1.1.1 Software version



The information in this document relates to software version:

Software	Version
SGC Application software	R19

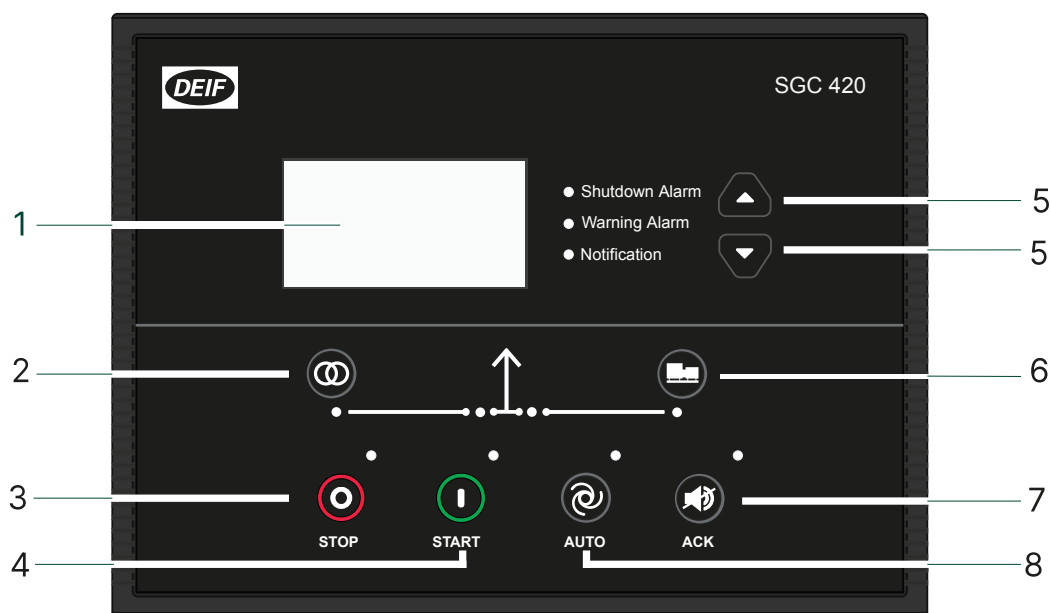
1.2 Display, buttons, and LEDs



No.	Name	Function
1	Display	Graphical
2	Mains breaker symbol	Push to open or close the mains breaker.
3	Stop	Stops the genset if MANUAL mode is selected. The controller opens the genset breaker and the cooling down time starts. If you push the Stop  button twice the engine stops immediately.

No.	Name	Function
3	Configure	Push and hold the Stop  button to go to the configuration menu. To exit the menu, push and hold the Stop  button. Push the Start  button to select a parameter, and to save the changes you have made.
4	Start	Starts the genset if MANUAL mode is selected.
5	Navigation	Move the selector up and down on the screen.
6	Genset breaker symbol	Push to open or close the genset breaker.
7	Acknowledge alarm	Push to acknowledge active alarms.
8	AUTO mode/ Mode selection	The controller automatically starts and stops (and connects and disconnects) the genset. No operator actions are needed. The controller also automatically opens and closes the mains breaker. Push the stop button to change the mode to MANUAL mode. To change to test mode, push and hold the AUTO button.

1.3 Protections overview

Generator protections

Protections	Alarms	ANSI
Under-voltage	2	27P
Over-voltage	2	59
Under-frequency	2	81U
Over-frequency	2	81O
Unbalanced load	1	-
Over-current	1	50TD
Overload	1	32F
Low load	1	-
Reverse power	1	32R
Phase reversal detection	1	-
Earth leakage/Fan current	1	-

Engine protections

Protections	Alarms	ANSI
Under-speed	1	14
Over-speed	1	12
Configurable crank connect	1	-
Battery monitoring	1	-
Charging alternator	1	-
Pre-heat	1	-
Coolant temperature	1	-
Lube oil pressure	1	-

Protections	Alarms	ANSI
Fuel level detection	1	-
Fuel theft detection	1	-
ECU communication failure	1	-
ECU diagnostic lamps	1	-

Mains protections

Protections	Alarms	ANSI
Under-voltage	1	27P
Over-voltage	1	59
Under-frequency	1	81U
Over-frequency	1	81O
Phase reversal detection	1	-

Other protections

Protections	Alarms	ANSI
Site battery	1	-
Shelter temperature	1	-

1.4 Functions

Genset functions
Start/stop sequences
Input for genset alternator voltage or D+ charging alternator
Counters, including: <ul style="list-style-type: none"> • Engine running hours • Start attempts • Energy (kWh, kVAh, kvarh) • Maintenance
Input for fuel reference selection
Fuel theft alarm
Monitoring of engine and alternator parameters
Idle speed control
Coolant temperature control
Automatic fuel transfer

Mains functions
Mains support (voltage and frequency)
Mains monitoring
Energy counter (kWh, kVAh, kvarh)

Site battery functions

Site battery monitoring

Shelter temperature monitoring

Differential input (± 60 V DC) for site battery voltage

General functions

Configurable analogue inputs (mA and V DC, and resistive)

Digital switch inputs

Digital outputs

Event logs with real-time clock

EEPROM for extended event logs

Cyclic timer

Auto-acknowledge warning alarms

2-level password protection

Display and language functions

Supports multiple languages, for example, English, Chinese and Spanish

Graphical display

Parameters can be changed on the display

Buttons on the display for breaker operations

Display views change automatically after an adjustable delay time

Deep sleep mode

LED lamps

Smart Connect Mk II

USB interface to PC

Free utility software

Data logging

Configuration comparison tool to compare customised values with default values

Customise and configure the language for the controller display and software

Possible to configure multiple profiles

Custom sensor curves can be added

M-Logic

Logic configuration tool

Selectable input events

Selectable output events

Analogue comparator to compare analogue values, and create custom alarms and logic functions

Use logic rungs to create custom logic

Running modes

MANUAL

AUTO

TEST

Modes of operation

Island

Automatic mains failure (AMF)

Remote start/stop

Auto exercise

Cyclic

Site battery monitoring and shelter temperature

Night restriction mode

Engine drive

Communication

RS-485 for Modbus

USB interface to PC

CAN

Remote Display Controller (RDC)

Remote display functionality using an SGC controller

SGC controller can be configured as a remote display for another SGC master controller

Mirrors operating values, alarms, and system status from the master controller

Can be configured to send control commands to the master controller

Communication via CAN (J1939)

Universal RDC 100 application software available for the SGC series

Any SGC controller can be configured as a remote display using RDC 100

1.5 Single-line application diagrams

Island mode

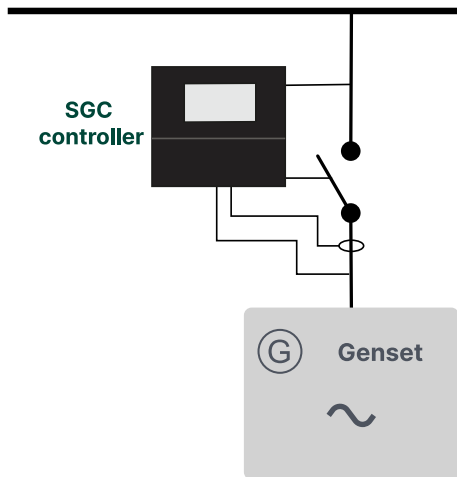

Island: Island mode is typically used in power plants that are isolated from other power generation systems.

Engine drive

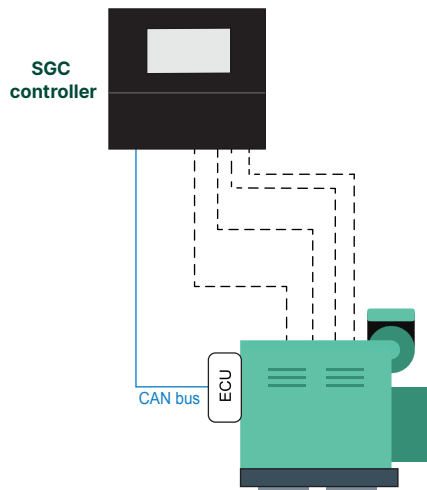

Engine drive: Use the controller to control one engine. The controller has all the necessary functions to control and protect the engine.

Automatic mains failure (AMF), remote start/stop, cyclic and auto exercise mode

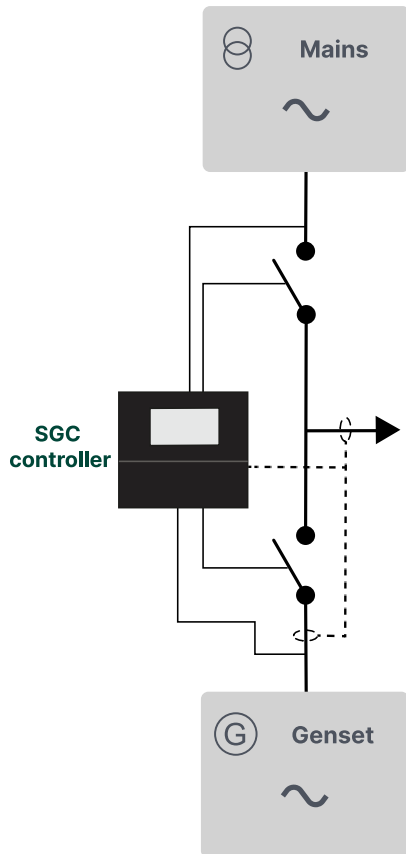

AMF: If there is a significant loss of mains power or a total blackout, the controller automatically changes the supply to the genset.

Remote start/stop: Activate the configured start/stop inputs to remotely start or stop the genset.

Cyclic: The genset operates for an adjustable amount of time during a mains failure.

Exercise mode: Use the auto exercise mode to schedule a maximum of two start/stop sequences for the genset.

NOTE You can place the CT on the line from the genset or on the load side.

Site battery monitoring mode

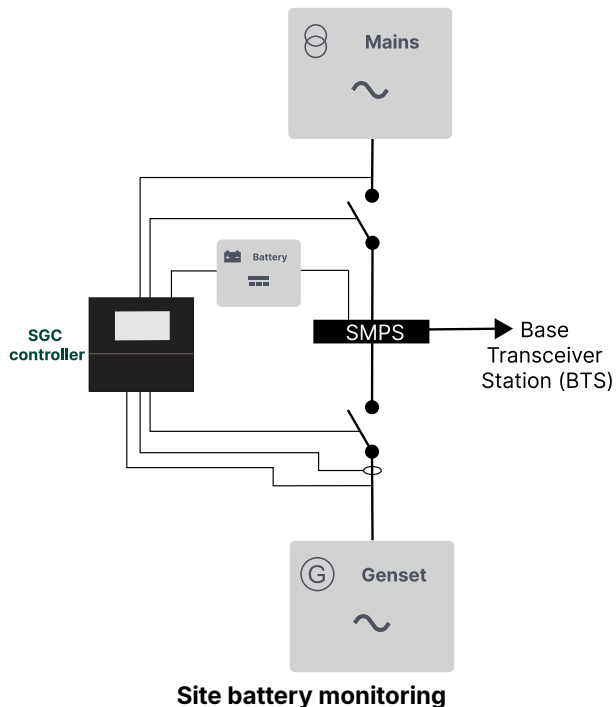

Site battery monitoring: Use this mode to monitor the site battery and the shelter temperature.

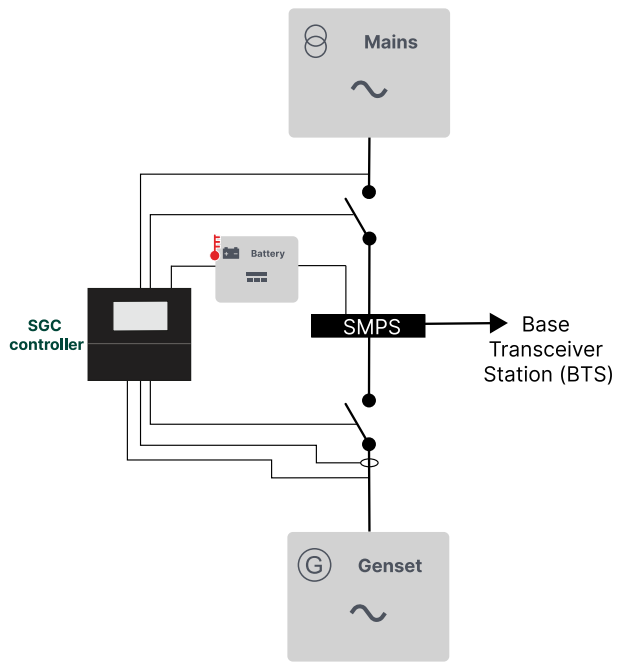

Shelter temperature monitoring

2. Technical specifications

2.1 Electrical specifications

Power supply	
Controller terminals	1 (Ground) 2 (Battery or DC+)
Supply voltage range	Nominal voltage: 12/24 V DC Operating range: 8 to 32 V DC
Cranking dropout period	50 ms
Maximum reverse voltage protection	-32 V DC
Measurement accuracy (battery voltage)	±1 % full scale
Resolution	0.1 V
Maximum current consumption	~ 200 mA, 12/24 V DC (not including the current load for the DC outputs)
Standby current consumption	180 mA, 12 V DC 140 mA, 24 V DC

Genset voltage and frequency measurements	
Controller terminals	54 (Neutral) 55 (L3) 56 (L2) 57 (L1)
Measurement type	True RMS
Phase-to-neutral voltage	32 to 300 V AC RMS
Phase-to-phase voltage	32 to 520 V AC RMS
Voltage accuracy	±1 % of full scale for phase-to-neutral ±1.5 % of full scale for phase-to-phase
Voltage resolution	1 V AC RMS for phase-to-neutral 2 V AC RMS for phase-to-phase
Frequency range	5 to 75 Hz
Frequency accuracy	0.25 % of full scale
Frequency resolution	0.1 Hz

NOTE For single phase applications, it is mandatory to connect:

- The genset phase (L1) to terminal 57 on the controller.
- The genset neutral to terminal 54 on the controller.

Genset current measurements	
Controller terminals	43 and 42 (for phase L1) 45 and 44 (for phase L2) 47 and 46 (for phase L3)
Measurement type	True RMS
Maximum CT secondary current rating	5 A 1 A

Genset current measurements

Burden	0.25 VA
Measurement accuracy	±1.4 % of nominal

Earth leakage and fan current monitoring

Controller terminals	48 and 49
Measurement type	True RMS
Maximum CT secondary current rating	5 A 1 A
Burden	0.25 VA
Measurement accuracy	±1.4 % of nominal

NOTE Use the recommended phase sequence when you connect the current transformer (CT).

Mains voltage and frequency measurements

Controller terminals	50 (Neutral) 51 (L3) 52 (L2) 53 (L1)
Measurement type	True RMS
Phase-to-neutral voltage	32 to 300 V AC RMS
Phase-to-phase voltage	32 to 520 V AC RMS
Voltage accuracy	±2 % of full scale for phase-to-neutral ±2.5 % of full scale for phase-to-phase
Voltage resolution	1 V AC RMS for phase-to-neutral 2 V AC RMS for phase-to-phase
Frequency range	5 to 75 Hz
Frequency accuracy	0.25 % of full scale
Frequency resolution	0.1 Hz

NOTE For single phase applications, it is mandatory to connect:

- The mains phase (L1) to terminal 53 on the controller.
- The mains neutral to terminal 50 on the controller.

Digital inputs

Controller terminals	33, 34, 35, 36, 37, 38, 39, 40, and 41
Number of inputs	9
Type	Negative switching
Maximum input voltage	+32 V
Minimum input voltage	-24 V
Current source	5 mA
Configurable parameters with software	For example, emergency stop, and remote start and stop.

Analogue resistive sensor inputs

Controller terminals	11, 12, 13, 14, and 15 (configurable)
Number of inputs	5
Type	Ratio-metric sensing
Range	10 to 5000 Ω
Open circuit detection	Above 5.5 k Ω
Measurement accuracy	± 2 % of full scale (up to 1000 Ω)

Analogue inputs used as digital inputs

You can use analogue inputs as digital inputs. See **Analogue inputs used as digital inputs** in the SGC 420 Mk II User manual for how to wire the analogue inputs and configure the parameters.

Analogue voltage/current inputs

Controller terminal	21 and 23 (configurable)
Measurement type	Analogue voltage/current sensing
Range	0 to 5 V DC 4 to 20 mA
Accuracy	± 1.25 % of full scale

Site battery inputs

Controller terminals	24 and 25
Number of inputs	2
Type	Differential
Range	± 60 V
Resolution	0.1 V
Accuracy	± 2 % of full scale

Magnetic pickup (MPU) input / W-point frequency input

Controller terminal	22
Measurement type	Single-ended
Frequency range	10 Hz to 10 kHz
Input voltage range	200 mV to 45 V AC RMS

D+ charger alternator

Controller terminal	10
Voltage range	0 to V_{BATT} $V_{BATT} = 8$ to 32 V DC
Excitation	PWM (power limited to 3 W, 12 V/250 mA, 24 V/125 mA)
Accuracy	± 2 % of full scale

Sensor common point (SCP)	
Controller terminal	16
Range	±2 V
Accuracy	±2 % of full scale

NOTE Connect terminal 16 (SCP) to a solidly grounded point on the engine, for example the engine frame. Do not share the cable used for this connection with other electrical connections.

Communication ports	
USB	USB 2.0 type B for connection to PC with Smart Connect Mk II
RS-485 serial port	Half duplex Max. baud rate: 115200 bps Data connection: 2-wire Common-mode operating range Maximum distance of line: 200 m Built-in termination resistor of 120 Ω between output terminals A and B (internally mounted)
Controller terminals	30 (GND) 31 (A) 32 (B)
CAN	Baud rate: 250 kbps Packet size: 8 bytes Built-in termination resistor of 120 Ω between output terminals A and B (internally mounted)
Controller terminals for CAN	58 and 59

Digital outputs	
Controller terminals	3, 4, 5, 6, 7, 8, and 9
Number of outputs	7
Type	DC outputs
Maximum current rating	5 A (3 and 4) 1 A (5, 6, 7, 8, 9)
Configurable parameters with software	For example, start relay or fuel relay.

2.2 Environmental specifications

Operation conditions	
Operating temperature	-20 to +65 °C (-4 to +149 °F). To IEC 60068-2-1, 2
Storage temperature	-30 to +75 °C (-22 to +167 °F). To IEC 60068-2-1, 2
Vibration	3G in X, Y and Z axes for 8 to 500 Hz. To IEC 60068-2-6
Shock	15 g for 11 ms. To IEC 60068-2-27
Humidity	0 to 95 % RH. To IEC 60068-2-78
Protection degree	IP65 (front of module when installed into the control panel with the supplied sealing gasket). To IEC 60529
EMI/EMC	IEC 61000-6-2, 4

2.3 Terminals

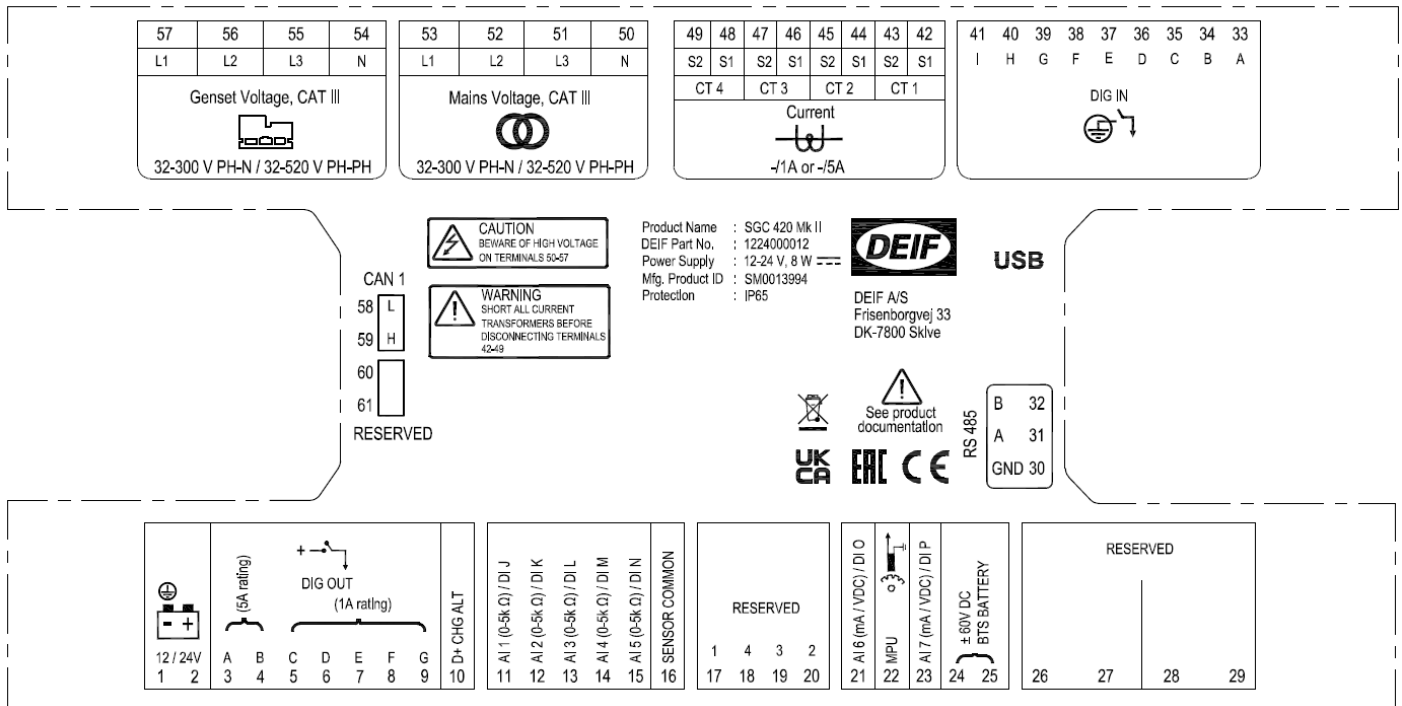

Terminal	Text	Description	Connector
1	GND	Power ground	BCP-508-10GN
2	BATT +	Power supply positive	
3	DIG OUT A	DC output - A (5 A rating)	
4	DIG OUT B	DC output - B (5 A rating)	
5	DIG OUT C	DC output - C (1 A rating)	
6	DIG OUT D	DC output - D (1 A rating)	
7	DIG OUT E	DC output - E (1 A rating)	
8	DIG OUT F	DC output - F (1 A rating)	
9	DIG OUT G	DC output - G (1 A rating)	
10	D+ CHG ALT	Input for charging alternator control	
11	AI 1 (0-5k Ω) / DI J	Analogue input from list of sensors/digital input J	BCP-508-6GN
12	AI 2 (0-5k Ω) / DI K	Analogue input from list of sensors/digital input K	
13	AI 3 (0-5k Ω) / DI L	Analogue input from list of sensors/digital input L	
14	AI 4 (0-5k Ω) / DI M	Analogue input from list of sensors/digital input M	
15	AI 5 (0-5k Ω) / DI N	Analogue input from list of sensors/Digital input N	
16	SENSOR COMMON	Sensor common point	

Terminal	Text	Description	Connector
17	RESERVED	-	N/A
18	RESERVED	-	
19	RESERVED	-	
20	RESERVED	-	
21	AI 6 (mA / VDC) / DI O	Analogue input from list of sensors/digital input O	BCP-508-5GN
22	MPU	Input from engine speed sensor (inductive)	
23	AI 7 (mA / VDC) / DI P	Analogue input from list of sensors/Digital input P	
24	BTS BATTERY ± 60 V DC	Input 1 from site battery	
25	BTS BATTERY ± 60 V DC	Input 2 from site battery	
26	RESERVED	-	N/A
27	RESERVED	-	
28	RESERVED	-	
29	RESERVED	-	
30	RS 485 GND	RS-485 GND	BCP-508-3GN
31	RS 485 A	RS-485 A	
32	RS 485 B	RS-485 B	
33	DIG IN A	Input from switch A	BCP-508-9GN
34	DIG IN B	Input from switch B	
35	DIG IN C	Input from switch C	
36	DIG IN D	Input from switch D	
37	DIG IN E	Input from switch E	
38	DIG IN F	Input from switch F	
39	DIG IN G	Input from switch G	
40	DIG IN H	Input from switch H	
41	DIG IN I	Input from switch I	
42	Current CT 1 S1	CT input 1 from phase L1 (-/1A or -/5A) (max. 2.5 mm ²)	BCP-508-8GN
43	Current CT 1 S2	CT input 2 from phase L1 (-/1A or -/5A) (max. 2.5 mm ²)	
44	Current CT 2 S1	CT input 1 from phase L2 (-/1A or -/5A) (max. 2.5 mm ²)	
45	Current CT 2 S2	CT input 2 from phase L2 (-/1A or -/5A) (max. 2.5 mm ²)	
46	Current CT 3 S1	CT input 1 from phase L3 (-/1A or -/5A) (max. 2.5 mm ²)	
47	Current CT 3 S2	CT input 2 from phase L3 (-/1A or -/5A) (max. 2.5 mm ²)	
48	Current CT 4 S1	CT input 1 from earth leakage (-/1A or -/5A) (max. 2.5 mm ²)	
49	Current CT 4 S2	CT input 2 from earth leakage (-/1A or -/5A) (max. 2.5 mm ²)	

Terminal	Text	Description	Connector
50	Mains Voltage, CAT III, N	Voltage input from mains neutral (32-300 V PH-N / 32-520 V PH-PH)	BCP-508-7GN-4PA
51	Mains Voltage, CAT III, L3	Voltage input from mains phase L3 (32-300 V PH-N / 32-520 V PH-PH)	
52	Mains Voltage, CAT III, L2	Voltage input from mains phase L2 (32-300 V PH-N / 32-520 V PH-PH)	
53	Mains Voltage, CAT III, L1	Voltage input from mains phase L1 (32-300 V PH-N / 32-520 V PH-PH)	
54	Genset Voltage, CAT III, N	Voltage input from genset neutral (32-300 V PH-N / 32-520 V PH-PH)	
55	Genset Voltage, CAT III, L3	Voltage input from genset phase L3 (32-300 V PH-N / 32-520 V PH-PH)	
56	Genset Voltage, CAT III, L2	Voltage input from genset phase L2 (32-300 V PH-N / 32-520 V PH-PH)	
57	Genset Voltage, CAT III, L1	Voltage input from genset phase L1 (32-300 V PH-N / 32-520 V PH-PH)	BCP-508-4GN
58	CAN L (Reserved)	CAN Low	
59	CAN H (Reserved)	CAN High	
60	Reserved	-	
61	Reserved	-	

2.4 Approvals

Standards
CE
UL/cUL Recognized to UL/ULC6200:2019 1st edition

NOTE Refer to deif.com for the most recent approvals.

2.5 Dimensions and weight

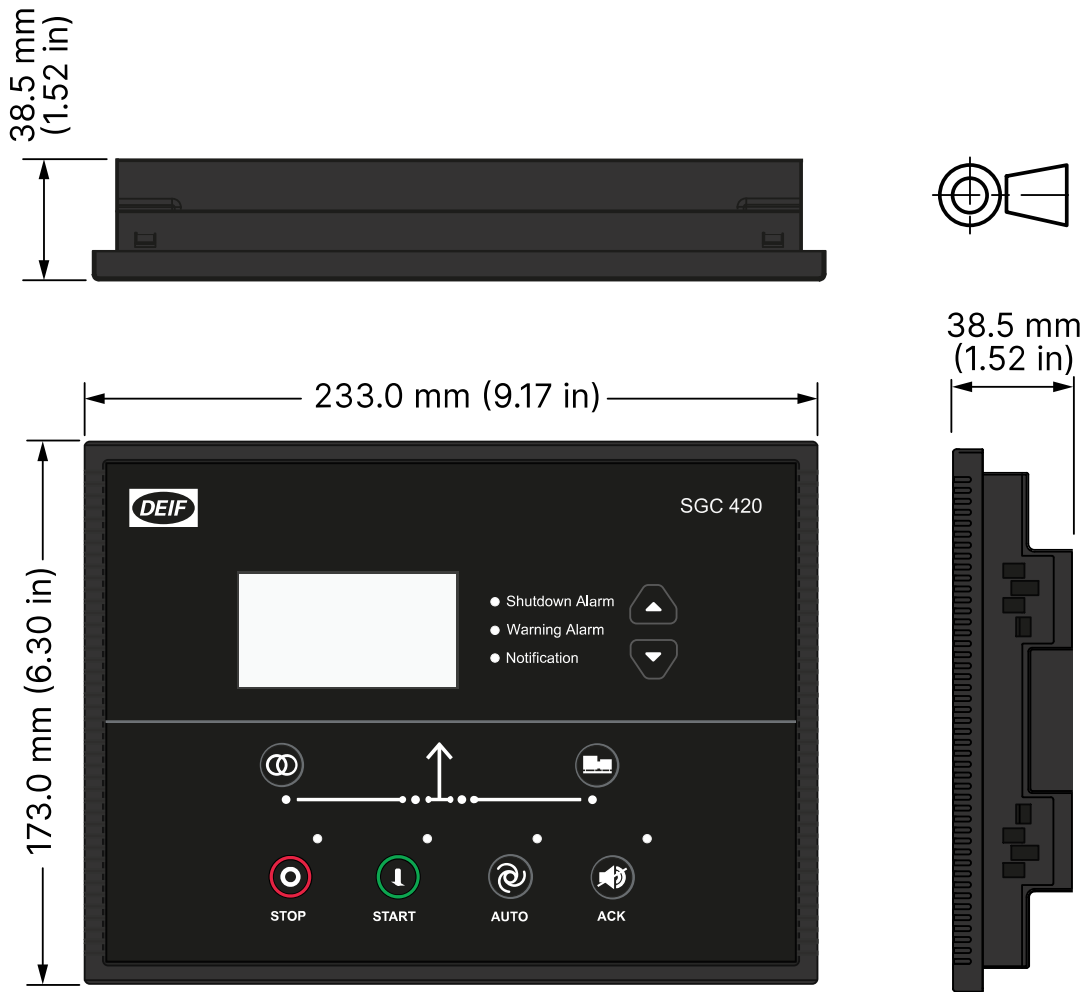

Dimensions

Dimensions	Length: 233.0 mm (9.17 in) Height: 173.0 mm (6.81 in) Depth: 38.5 mm (1.52 in)
Panel cut-out	Length: 219.0 mm (8.62 in) Height: 158.0 mm (6.22 in) Tolerance: ± 0.3 mm (0.01 in)
Weight	With lock: 672 g Without lock: 640 g

3. Legal information

Warranty

NOTICE



Warranty

The controller is not to be opened by unauthorised personnel. If opened anyway, the warranty will be lost.

Disclaimer

DEIF A/S reserves the right to change any of the contents of this document without prior notice.

The English version of this document always contains the most recent and up-to-date information about the product. DEIF does not take responsibility for the accuracy of translations, and translations might not be updated at the same time as the English document. If there is a discrepancy, the English version prevails.

Copyright

© Copyright DEIF A/S. All rights reserved.