

iE 250 PLC

Programmable Automation Controller

Data sheet

4921240653-M



Improve
Tomorrow



1. Intelligent energy controller

1.1 About the controller	4
1.1.1 Software versions.....	4
1.2 Functions and features	4
1.2.1 General functions and features.....	4
1.3 Applications	6
1.3.1 Applications.....	6
1.3.2 Extension rack functions.....	6
1.4 Compatible products	6
1.4.1 Additional inputs and outputs.....	6
1.4.2 Other equipment.....	8

2. Technical specifications

2.1 Dimensions	9
2.1.1 iE 250 (7"): Front-mounted controller with MIO2.1.....	9
2.1.2 iE 250 (Base): Base-mounted controller with MIO2.1.....	10
2.1.3 iE 7 display.....	11
2.1.4 Plug-in module for 8 Digital bi-directional channels (PIM-8DIO).....	12
2.1.5 Plug-in module for 4 Analogue bi-directional channels (PIM-4AIO).....	13
2.2 Mechanical specifications	14
2.2.1 iE 250 (7"): Front-mounted controller with MIO2.1.....	14
2.2.2 iE 250 (Base): Base-mounted controller with MIO2.1.....	15
2.2.3 iE 7 display.....	16
2.3 Environmental specifications	17
2.3.1 iE 250 (7"): Front-mounted controller with MIO2.1.....	17
2.3.2 iE 250 (Base): Base-mounted controller with MIO2.1.....	17
2.3.3 iE 7 display.....	17
2.4 Controller	19
2.4.1 Terminal connections.....	19
2.4.2 Electrical specifications.....	19
2.4.3 Communication specifications.....	21
2.4.4 Technical specifications.....	21
2.5 iE 7 display	24
2.5.1 Terminal connections.....	24
2.5.2 Electrical specifications.....	24
2.5.3 Communication specifications.....	24
2.6 Measurement Input Output module (MIO2.1)	26
2.6.1 About.....	26
2.6.2 Terminal connections.....	26
2.6.3 Electrical specifications.....	27
2.6.4 Communication specifications.....	29
2.7 Plug-in module for 8 Digital bi-directional channels (PIM-8DIO)	30
2.8 Plug-in module for 4 Analogue bi-directional channels (PIM-4AIO)	31
2.9 Accessories	32
2.9.1 DIN rail clamps.....	32
2.9.2 USB type A to C cable.....	32
2.9.3 DisplayPort cable.....	32
2.9.4 Ethernet cable.....	32
2.10 Approvals	33
2.11 Cybersecurity	33

3. Application development

3.1 IEC61131-3 programming.....	34
3.2 Supported software features.....	34

4. Legal information

4.1 Disclaimer and copyright.....	36
-----------------------------------	----

1. Intelligent energy controller

1.1 About the controller

1.1.1 Software versions

The information in this document relates to software versions:

Software	Details	Version
iE PLC Bundle	Signed Software bundle with components:	2.0.11.x
BSP	Board Support Package (Operating System)	5.0.0.x
CODESYS	CODESYS runtime	3.5.20.40 or later
CODESYS IDE	PC software for development of CODESYS applications	3.5.20.40 or later
CODESYS TSP	iE 250 CODESYS Target Support Package (TSP)	1.3.4.x or later

1.2 Functions and features

1.2.1 General functions and features

Modular and configurable design	
Mounting choices	Choice of either: <ul style="list-style-type: none">• iE 250 (7") Front-mounted• iE 250 (Base) Base-mounted
New design – easy mount	Front-mounted controller or display has same cut-out footprint as the iE 150 and AGC 150.
Easy expansion	Add-on modules <ul style="list-style-type: none">• Measurement Input Output module MIO2.1. Plug-in modules <ul style="list-style-type: none">• 8 Digital bi-directional channels (PIM-8DIO).• 4 Analogue bi-directional channels (PIM-4AIO). Additional input/output possibilities <ul style="list-style-type: none">• 300 series modules using EtherCAT.• 600 series modules with CODESYS using EtherCAT.

General functions	
CODESYS	CODESYS runtime. View CODESYS license type in WebConfig.
Security	Secure update with signed update packages. Dual partition for safe update. Secure boot - only signed software will run.
DEIF libraries	DEIF OPC UA library for CODESYS - based on open62541.
Application development	CODESYS IDE.

Communication	
Plug and play	Automatic network configuration (uses static IPv6) NTP time synchronisation with NTP servers
Communication	<ul style="list-style-type: none">• Internet Protocol version 6 (IPv6) with SLAAC

Communication

	<ul style="list-style-type: none">Configurable Internet Protocol version 4 (IPv4)
CAN bus communication	3 CAN ports for: <ul style="list-style-type: none">CODESYS J1939CANopen CODESYS
RS-485 communication	2 serial ports configurable as client or server
Network	3 port switch and 1 Ethernet port, bridged or standalone

WebConfig

WebConfig	A browser-based tool to connect to the controller IP address. View controller information. Manage cybersecurity configuration. If required, restart the controller or do a factory reset.
------------------	--

1.3 Applications

1.3.1 Applications

Example PLC application

An example application with the PLC controller connected to 2 extension racks with EtherCAT.

For this application, enable *Redundancy* on the CODESYS EtherCAT master General tab and specify *ETH0* as Network Interface for EtherCAT cable redundancy return channel.

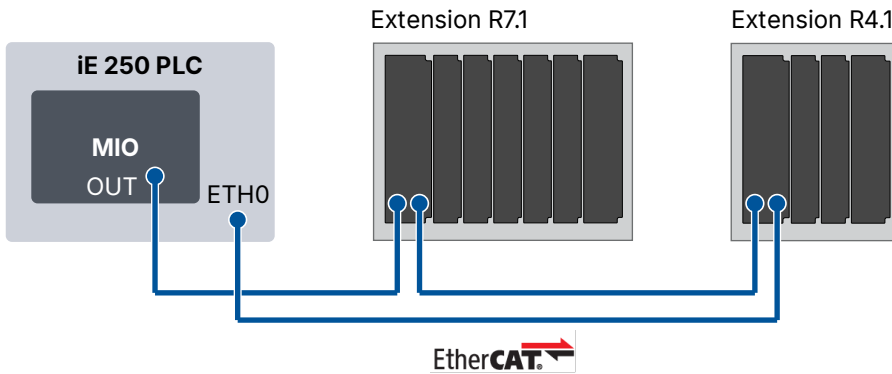

1.3.2 Extension rack functions

	Functions
General	<ul style="list-style-type: none">• Extends I/O interface<ul style="list-style-type: none">◦ 6 additional hardware modules in Rack7.1◦ 3 additional hardware modules in Rack4.1

1.4 Compatible products

1.4.1 Additional inputs and outputs

Series 300 extension modules

You can use the Series 300 extensions racks and range of modules.



More information

See www.deif.com/products/series-300-modules/ for information about all the racks and modules.

Extension racks

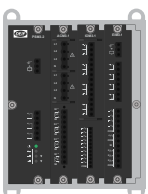

Extension rack R4.1

1 PSM3.2
3 module selection

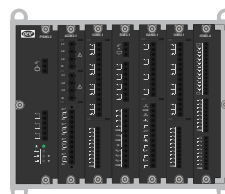

Extension rack R7.1

1 PSM3.2
6 module selection

Modules



IOM3.1 - Input/output module

4 changeover relay outputs
10 digital inputs



IOM3.2 - Input/output module

4 relay outputs
4 analogue multifunctional outputs (including 2 pulse width modulation PWM outputs)
4 digital inputs
4 analogue multifunctional inputs



IOM3.3 - Input/output module

10 analogue multifunctional inputs



IOM3.4 - Input/output module

12 digital outputs
16 digital inputs

iE 650 modules

You can use CODESYS to use modules from iE 650.



More information

See the **iE 650 PLC Data sheet** for details of these modules.

Rack6-4 (4 slots)

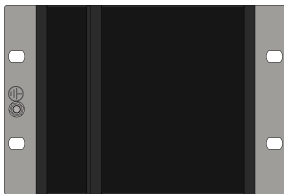

Rack6-14 (14 slots)

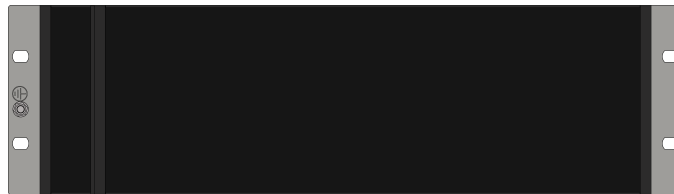

Racks with 6, 8, 10, and 12 slots are also available.

Modules



DIO6-2 - Input/output module

16 digital inputs
16 digital outputs



DIM6-1 - Input module

32 digital inputs



DOM6-1 - Output module

32 digital outputs



AIO6-2 - Input/output module

8 analogue outputs
8 analogue inputs



AOM6-2 - Output module

8 analogue inputs



AIM6-1 - Input module

16 analogue outputs
(Use AIM6-2 if only 8 analogue outputs are required)

1.4.2 Other equipment

DEIF has a wide variety of other equipment that is compatible. This includes synchrosopes, meters, transducers, current transformers, power supplies, and battery chargers.



More information

See www.deif.com

2. Technical specifications

2.1 Dimensions

2.1.1 iE 250 (7"): Front-mounted controller with MIO2.1

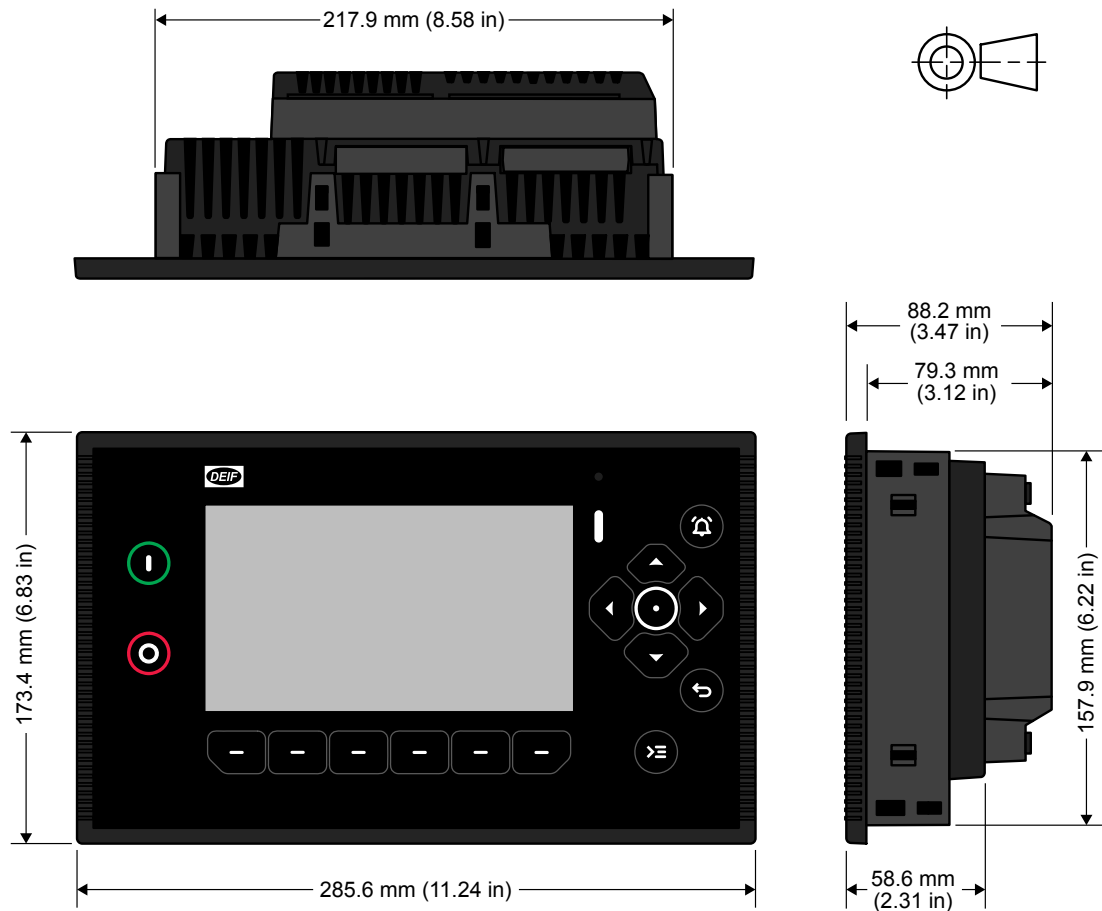

Category	Specifications
Dimensions	With MIO: L×H×D: 285.6 × 173.4 × 88.2 mm (11.24 × 6.83 × 3.47 in) (outer frame) Without MIO: L×H×D: 285.6 × 173.4 × 58.6 mm (11.24 × 6.83 × 2.30 in) (outer frame)
Panel cutout	L×H: 220 × 160 mm (8.67 × 6.30 in) Tolerance: ± 0.3 mm (0.01 in)
Weight	With MIO: ~ 1233 g (2.72 lb)

Category	Specifications
Display	7", Projected Capacitive (PCAP), Touch
Resolution	1024x600 pixels (px)
Brightness	1200 Cd/m ²

2.1.2 iE 250 (Base): Base-mounted controller with MIO2.1

The base-mounted version is shown mounted on DIN rail. It can alternatively be mounted using the mounting holes with fixing screws or bolts.

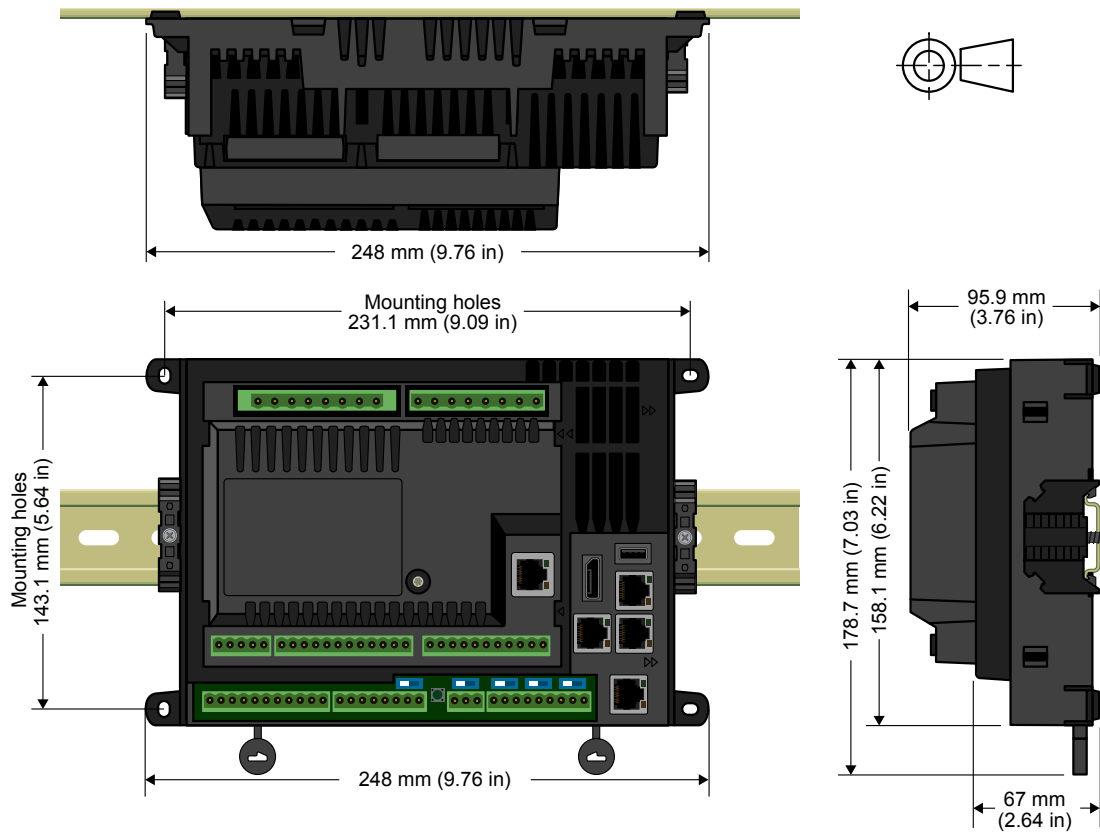

Category	Specifications
Dimensions	With MIO: L×H×D: 248 × 178.7 × 95.9 mm (9.76 × 7.03 × 3.76 in) (outer frame)
	Without MIO: L×H×D: 248 × 178.7 × 67 mm (9.76 × 7.03 × 2.64 in) (outer frame)
Mounting holes	L×H: 231.1 × 143.1 mm (9.09 × 5.64 in)
Weight	With MIO: ~ 942 g (2.07 lb)

2.1.3 iE 7 display

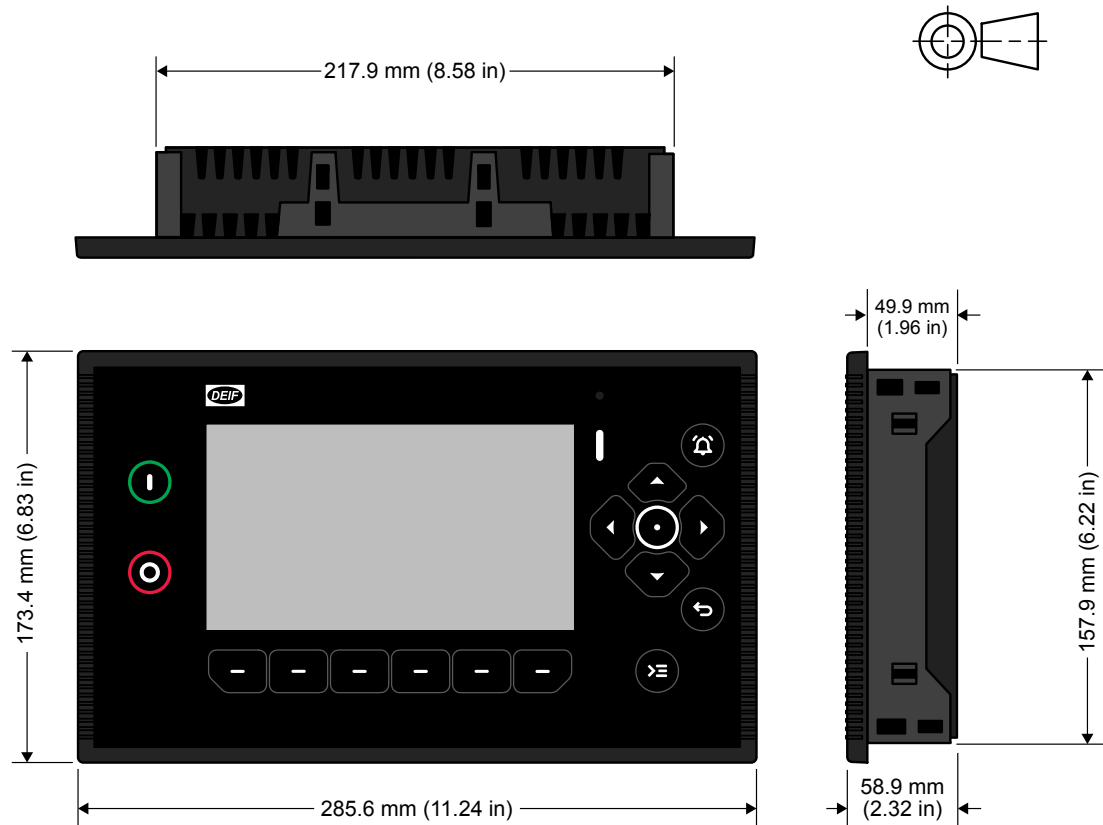

Category	Specifications
Dimensions	L×H×D: 285.6 × 173.4 × 58.9 mm (11.24 × 6.83 × 2.32 in) (outer frame)
Panel cutout	L×H: 220 × 160 mm (8.67 × 6.30 in)
Weight	840 g (1.9 lb)

Category	Specifications
Display	7", Projected Capacitive (PCAP), Touch
Resolution	1024x600 pixels (px)
Brightness	1200 Cd/m ²
Processor	1.6 GHz quad-core industrial grade ARMv8 64 bit CPU with ECC protected cache

2.1.4 Plug-in module for 8 Digital bi-directional channels (PIM-8DIO)

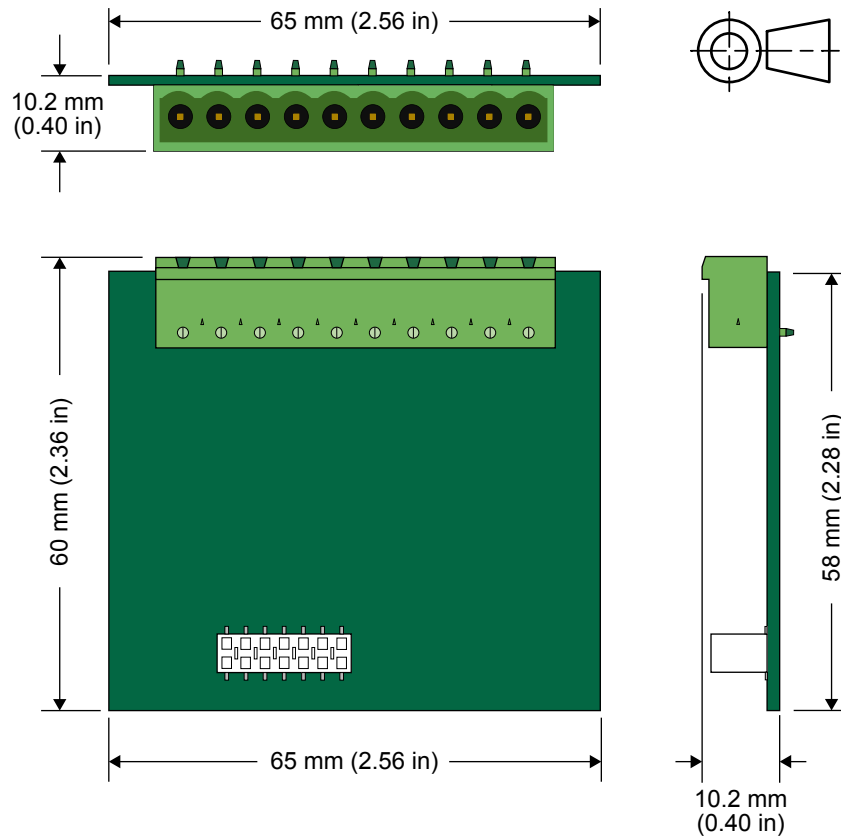

Category	Specifications
Dimensions	L×H×D: 65 × 60 × 10.2 mm (2.56 × 2.36 × 0.40 in) (outer frame)
Weight	24 g (0.05 lb)

2.1.5 Plug-in module for 4 Analogue bi-directional channels (PIM-4AIO)

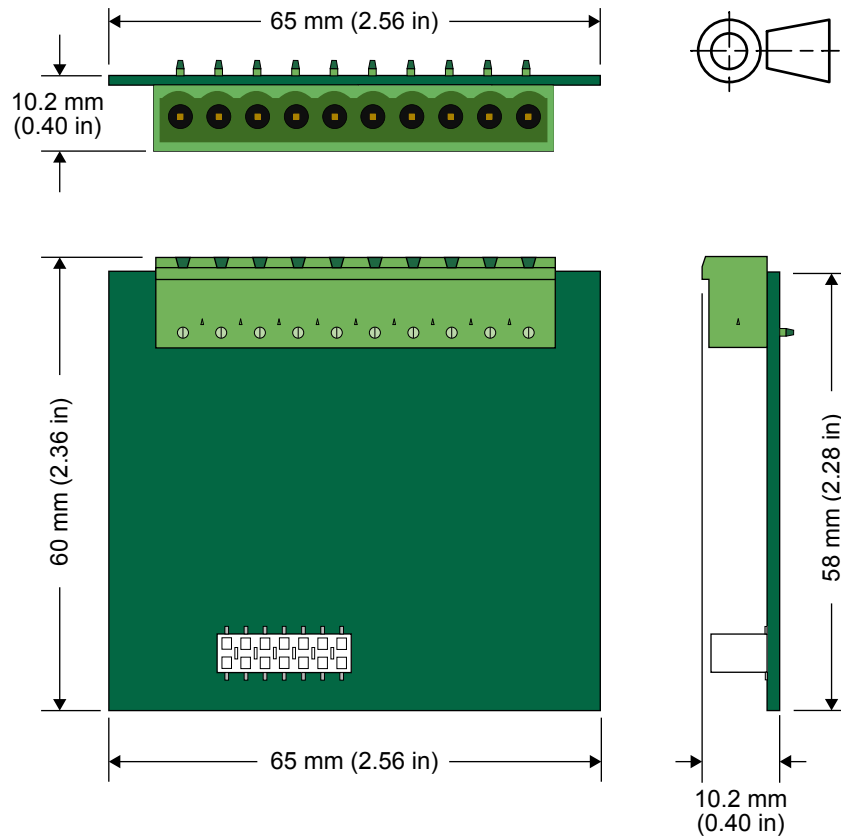

Category	Specifications
Dimensions	L×H×D: 65 × 60 × 10.2 mm (2.56 × 2.36 × 0.40 in) (outer frame)
Weight	24 g (0.05 lb)

2.2 Mechanical specifications

2.2.1 iE 250 (7"): Front-mounted controller with MIO2.1

Mechanical specifications	
Vibration	<p>Response:</p> <ul style="list-style-type: none"> 10 to 58.1 Hz, 0.15 mmpp 58.1 to 150 Hz, 1 g. To IEC 60255-21-1 (Class 2) <p>Endurance:</p> <ul style="list-style-type: none"> 10 to 150 Hz, 2 g. To IEC 60255-21-1 (Class 2) <p>Seismic vibration:</p> <ul style="list-style-type: none"> 3 to 8.15 Hz, 15 mmpp 8.15 to 35 Hz, 2 g. To IEC 60255-21-3 (Class 2)
Shock	<p>10 g, 11 ms, half sine. To IEC 60255-21-2 Response (Class 2)</p> <p>30 g, 11 ms, half sine. To IEC 60255-21-2 Withstand (Class 2)</p> <p>50 g, 11 ms, half sine. To IEC 60068-2-27, test Ea</p> <p>Tested with three impacts in each direction in three axes (total of 18 impacts per test)</p>
Bump	<p>20 g, 16 ms, half sine IEC 60255-21-2 (Class 2)</p> <p>Tested with 1000 impacts in each direction on three axes (total of 6000 impacts per test)</p>
Controller galvanic separation	<p>Supply and DIO 1 to 8: 550 V, 50 Hz, 1 minute</p> <p>AIO 1 to 4: 550 V, 50 Hz, 1 minute</p> <p>COM 1 (RS-485): 550 V, 50 Hz, 1 minute</p> <p>COM 2 (RS-485): 550 V, 50 Hz, 1 minute</p> <p>CAN A: 550 V, 50 Hz, 1 minute</p> <p>CAN B: 550 V, 50 Hz, 1 minute</p> <p>CAN C: 550 V, 50 Hz, 1 minute</p> <p>Ethernet port 1: 550 V, 50 Hz, 1 minute</p> <p>Ethernet port 2: 550 V, 50 Hz, 1 minute</p> <p>Ethernet port 3: 550 V, 50 Hz, 1 minute</p> <p>Ethernet ETH0 / Ethernet 0 : 550 V, 50 Hz, 1 minute</p>
Controller ports without galvanic separation	<p>Display port, USB port</p>
MIO2.1 galvanic separation	<p>AO1: 550 V, 50 Hz, 1 minute</p> <p>AO2: 3000 V, 50 Hz, 1 minute</p> <p>AC current via internal transformers (I4, I1, I2, I3): 2210 V, 50 Hz, 1 minute</p> <p>AC voltage A-side (N, L1, L2, L3): 3310 V, 50 Hz, 1 minute</p> <p>AC voltage B-side (N, L1, L2, L3): 3310 V, 50 Hz, 1 minute</p> <p>EtherCAT port: 550 V, 50 Hz, 1 minute</p>
MIO2.1 terminals without galvanic separation	<p>D+ and DIO 9 to 16, DI 1 to 8 and tacho</p>
Safety	<p>Installation CAT. III 600 V</p> <p>Pollution degree 2</p> <p>IEC 60255-27</p>
Flammability	<p>All plastic parts are self-extinguishing to UL94-V0</p>
EMC	<p>IEC 60255-26</p>

NOTE g = gravitational force (g-force).

2.2.2 iE 250 (Base): Base-mounted controller with MIO2.1

Mechanical specifications	
Vibration	<p>Response:</p> <ul style="list-style-type: none"> 10 to 58.1 Hz, 0.15 mmpp 58.1 to 150 Hz, 1 g. To IEC 60255-21-1 (Class 2) <p>Endurance:</p> <ul style="list-style-type: none"> 10 to 150 Hz, 2 g. To IEC 60255-21-1 (Class 2) <p>Seismic vibration:</p> <ul style="list-style-type: none"> 3 to 8.15 Hz, 15 mmpp 8.15 to 35 Hz, 2 g. To IEC 60255-21-3 (Class 2)
Shock	<p>10 g, 11 ms, half sine. To IEC 60255-21-2 Response (Class 2) *</p> <p>30 g, 11 ms, half sine. To IEC 60255-21-2 Withstand (Class 2)</p> <p>50 g, 11 ms, half sine. To IEC 60068-2-27, test Ea</p> <p>Tested with three impacts in each direction in three axes (total of 18 impacts per test)</p>
Bump	<p>20 g, 16 ms, half sine IEC 60255-21-2 (Class 2) *</p> <p>Tested with 1000 impacts in each direction on three axes (total of 6000 impacts per test)</p>
Controller galvanic separation	<p>Supply and DIO 1 to 8: 550 V, 50 Hz, 1 minute</p> <p>AIO 1 to 4: 550 V, 50 Hz, 1 minute</p> <p>COM 1 (RS-485): 550 V, 50 Hz, 1 minute</p> <p>COM 2 (RS-485): 550 V, 50 Hz, 1 minute</p> <p>CAN A: 550 V, 50 Hz, 1 minute</p> <p>CAN B: 550 V, 50 Hz, 1 minute</p> <p>CAN C: 550 V, 50 Hz, 1 minute</p> <p>Ethernet port 1: 550 V, 50 Hz, 1 minute</p> <p>Ethernet port 2: 550 V, 50 Hz, 1 minute</p> <p>Ethernet port 3: 550 V, 50 Hz, 1 minute</p> <p>Ethernet ETH0 / Ethernet 0 : 550 V, 50 Hz, 1 minute</p>
Controller ports without galvanic separation	<p>Display port, USB port</p>
MIO2.1 galvanic separation	<p>AO1: 550 V, 50 Hz, 1 minute</p> <p>AO2: 3000 V, 50 Hz, 1 minute</p> <p>AC current via internal transformers (I4, I1, I2, I3): 2210 V, 50 Hz, 1 minute</p> <p>AC voltage A-side (N, L1, L2, L3): 3310 V, 50 Hz, 1 minute</p> <p>AC voltage B-side (N, L1, L2, L3): 3310 V, 50 Hz, 1 minute</p> <p>EtherCAT port: 550 V, 50 Hz, 1 minute</p>
MIO2.1 terminals without galvanic separation	<p>D+ and DIO 9 to 16, DI 1 to 8 and tacho</p>
Safety	<p>Installation CAT. III 600 V</p> <p>Pollution degree 2</p> <p>IEC 60255-27</p>
Flammability	<p>All plastic parts are self-extinguishing to UL94-V0</p>
EMC	<p>IEC 60255-26</p>

NOTE * With DIN rail clamp end-stop mounted tight to the unit. See [DIN rail clamp](#) for the type of DIN clamp required.
g = gravitational force (g-force).

2.2.3 iE 7 display

Mechanical specifications	
Vibration	<p>Response:</p> <ul style="list-style-type: none"> • 10 to 58.1 Hz, 0.15 mmpp • 58.1 to 150 Hz, 1 g. To IEC 60255-21-1 (Class 2) <p>Endurance:</p> <ul style="list-style-type: none"> • 10 to 150 Hz, 2 g. To IEC 60255-21-1 (Class 2) <p>Seismic vibration:</p> <ul style="list-style-type: none"> • 3 to 8.15 Hz, 15 mmpp • 8.15 to 35 Hz, 2 g. To IEC 60255-21-3 (Class 2)
Shock	<p>10 g, 11 ms, half sine. To IEC 60255-21-2 Response (Class 2)</p> <p>30 g, 11 ms, half sine. To IEC 60255-21-2 Withstand (Class 2)</p> <p>50 g, 11 ms, half sine. To IEC 60068-2-27, test Ea</p> <p>Tested with three impacts in each direction in three axes (total of 18 impacts per test)</p>
Bump	<p>20 g, 16 ms, half sine IEC 60255-21-2 (Class 2)</p> <p>Tested with 1000 impacts in each direction on three axes (total of 6000 impacts per test)</p>
Controller ports without galvanic separation	DisplayPort, USB ports
Safety	<p>Installation CAT. III 600 V</p> <p>Pollution degree 2</p> <p>IEC 60255-27</p>
Flammability	All plastic parts are self-extinguishing to UL94-V0
EMC	IEC 60255-26

NOTE g = gravitational force (g-force).

2.3 Environmental specifications

2.3.1 iE 250 (7"): Front-mounted controller with MIO2.1

Environmental specifications	
Operating temperature	-30 to 70 °C (-22 to 158 °F)
Storage temperature	-30 to 80 °C (-22 to 176 °F)
Change of temperature	70 to -30 °C, 1 °C / minute, 5 cycles. To IEC 60255-1
Operating altitude	0 to 4000 m above sea level 2001 to 4000 m: Maximum 480 V AC
Operating humidity	Damp heat cyclic, Condensing. <ul style="list-style-type: none"> Low temperature: 25°C / 97% Relative humidity (RH), high temperature: 55°C / 93% Relative humidity (RH), for 144 hours. To EN IEC 60255-1. Damp heat steady state, Non-Condensing. <ul style="list-style-type: none"> 40°C / 93% Relative humidity (RH), for 240 hours. To EN IEC 60255-1.
Protection degree	EN IEC 60529 <ul style="list-style-type: none"> IP65 (front of module when installed into the control panel with the supplied sealing gasket) IP20 on terminal side

2.3.2 iE 250 (Base): Base-mounted controller with MIO2.1

Environmental specifications	
Operating temperature	-30 to 70 °C (-22 to 158 °F)
Storage temperature	-30 to 80 °C (-22 to 176 °F)
Change of temperature	70 to -30 °C, 1 °C / minute, 5 cycles. To IEC 60255-1
Operating altitude	0 to 4000 m above sea level 2001 to 4000 m: Maximum 480 V AC
Operating humidity	Damp heat cyclic, Condensing. Low temperature: 25°C / 97%RH, high temperature: 55°C / 93%RH, for 144 hours. To EN /IEC 60255-1. Damp heat steady state, Non-Condensing. 40°C / 93%RH, for 240 hours. To EN /IEC 60255-1.
Protection degree	EN IEC 60529 <ul style="list-style-type: none"> IP20 on terminal side

2.3.3 iE 7 display

Environmental specifications	
Operating temperature	-30 to 70 °C (-22 to 158 °F)
Storage temperature	-30 to 80 °C (-22 to 176 °F)
Change of temperature	70 to -30 °C, 1 °C / minute, 5 cycles. To IEC 60255-1
Operating altitude	0 to 4000 m above sea level 2001 to 4000 m: Maximum 480 V AC
Operating humidity	Damp heat cyclic, 20/55 °C at 97 % relative humidity, 144 hours. To IEC 60255-1

Environmental specifications

	Damp heat steady state, 40 °C at 93 % relative humidity, 240 hours. To IEC 60255-1
Protection degree	EN IEC 60529 <ul style="list-style-type: none">• IP65 (front of module when installed into the control panel with the supplied sealing gasket)• IP20 on terminal side

2.4 Controller

2.4.1 Terminal connections

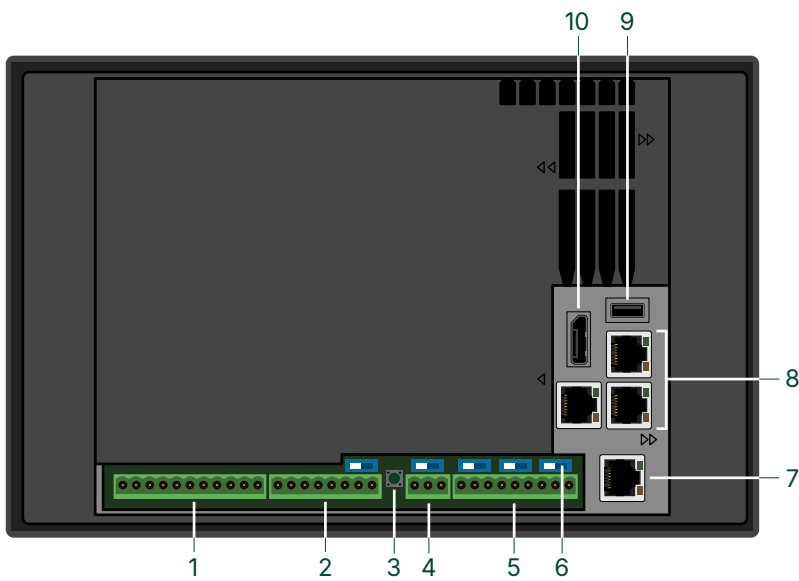

No.	Function	Notes
1	Power supply Digital bi-directional channels	1 Power supply (DC+/-) 8 Bi-directional digital channels DC(+) for DIO 4 to 8
2	COM 1 Analogue bi-directional channels	1 RS-485 4 Bi-directional analogue channels
3	Push-button	
4	COM 2	1 RS-485
5	CAN	3 CAN connections
6	Built-in end resistors	5 switches to enable the end resistors 120 Ω (Ohm) for CAN or Serial termination
7	ETH0 / Ethernet 0	1 Ethernet connection bridged to switch
8	Ethernet	3 Ethernet switch connections (SWP1,SWP2,SWP3)
9	USB	USB host (type A)
10	DisplayPort	For use with the base-mounted version. External third-party non-DEIF displays should be configured to Input mode instead of Automatic detection.

2.4.2 Electrical specifications

Power supply	
Input voltage	Nominal voltage: 12 V DC or 24 V DC (Operation range: 6.5 to 36 V DC) Power up at 8 V Operation down to 6.5 V at 15 W
Start current	Power supply current limiter <ul style="list-style-type: none"> 24 V: 4 A minimum 12 V: 8 A minimum Battery: No limit

Power supply

Voltage withstand	Reverse polarity
Power supply drop-out immunity	0 V DC for 50 ms (coming from more than 6.5 V DC) at 15 W
Power supply load dump protection	Load dump protected according to ISO16750-2 test A
Power consumption	15 W typical

Analogue bi-directional channels

4 individual channels (isolated group) with configurable function.
Configurable as input or output channels.
Galvanic separation to CPU
All channels in one electric group

Input channels

Digital input	0 to 24 V DC with common threshold 4 V
Resistor measurement	Range: 0 to 1 M Ω Accuracy 0 to 80 Ω : $\pm 1\%$ $\pm 0.5\ \Omega$ 80 Ω to 10 k Ω : $\pm 0.4\%$ 10 to 20 k Ω : $\pm 0.5\%$ 20 to 200 k Ω : $\pm 1.5\%$ 200 to 1000 k Ω : $\pm 12\%$
Voltage input	0 to 10 V DC (16-bit sigma delta) Accuracy: 0.5 % of full scale over the operating temperature range. Input impedance: 200 k Ω .
Current input	0 to 20 mA (16-bit sigma delta) Accuracy: 0.6 % of full scale over the operating temperature range.
Output channels	
Voltage output	0 to 10 V DC (13-bit resolution) Accuracy: 0.5 % of full scale over the operating temperature range.
Current output	0 to 20 mA (13-bit resolution) Accuracy: 0.6 % of full scale over the operating temperature range. Maximum 2 channels can be selected as current output (internal power limitation)

Digital bi-directional channels

8 individual channels (one galvanic isolated group) with configurable function.
Configurable as input or output channels.

Modes:

- Disabled
- Digital input (sourcing) (negative switching)
- Digital input (sinking) (positive switching)
- Digital output (sourcing)
- Digital output (sourcing) with wire break detection

Digital input channels	0 to 24 V DC Current source (contact cleaning): Initial 10 mA, continuous 2 mA
Digital output channels	Output voltage: 12 to 24 V DC Digital output switch output voltage is dependant on DC+ <ul style="list-style-type: none">• DIO channels 1 to 4 use terminal 1.• DIO channels 5 to 8 use terminal 7.

Digital bi-directional channels	
	2 A DC inrush and 0.5 A continuous (maximum 2 A for continuous for all channels)

Real-Time Clock (RTC) battery	
Battery type	CR2430 3V battery, rated for operation at -40 to 85°C (-40 to 185 °F). This is not a standard CR2430 battery.

2.4.3 Communication specifications

Communication specifications	
CAN A CAN B CAN C	Data connection 2-wire and common (isolated) Switch 120 Ω (ohm) termination resistors
COM 1 (RS-485)	Data connection 2-wire and common (isolated) Switch 120 Ω (ohm) termination resistors
COM 2 (RS-485)	Data connection 2-wire and common (isolated) Switch 120 Ω (ohm) termination resistors
USB	USB host (type A)
3 Ethernet (SWP1, SWP2, SWP3)	Switch for Ethernet connections RJ45 Use an Ethernet cable that meets or exceeds the SF/UTP CAT5e specifications
ETH0 / Ethernet 0	Ethernet bridged to the switch RJ45 Use an Ethernet cable that meets or exceeds the SF/UTP CAT5e specifications
DisplayPort	For base-mounted versions only Connection to a display

2.4.4 Technical specifications

Category	Specification
Ethernet	1 x Ethernet (prepared for TSN support) (ETH 0): 100/100BASE-T, 8P8C (RJ45), shielded Cat5e, >0.76 μm gold plating. 3 x Ethernet, Managed Switch (ETH 1 to 3): 10/100BASE-T, 8P8C (RJ45), shielded Cat5e, >0.76 μm gold plating.
CAN	3 x CAN (CAN 1 to 3): ISO 11898, shielded twisted copper cable, 50 to 1000 kbit/s, selectable termination resistors.
UART	COM 1 and COM 2: 2(1) x RS-485 (COM 1, COM 2) : TIA/EIA-485 shielded twisted copper cable 4.8 to 921.6 kbit/s (half duplex) COM 1 only: 1 x RS-232 (COM 1) : TIA/EIA-232E shielded copper cable 4.8 to 115.2 kbit/s (full duplex)
DisplayPort	1 x DisplayPort(DP) 1.3 1080p (Full-size connector).
USB Host	1x USB 3.0 (Type-A connector), Mass Storage Class. Power delivery up to 4.5 W.
Pin-hole switch	Factory Reset
CPU	
Processor	1.6 GHz Quad-core industrial grade ARMv8 64 bit CPU with ECC protected cache.

Category	Specification
Memory	2 GB LPDDR4.
Internal storage	32 GB 3D TLC NAND flash running in pseudo SLC mode. 7 GB available for user application data.
Persistent storage	128 kB user available from CODESYS (256 kB FRAM installed).
Cooling	Passive.
Other features	CPU junction temperature measurement. Software reset on high CPU temperature.
Software	
Operating system	DEIF In-house maintained operating system (BSPv5). Real-time patched Linux®. GNU/Linux customized with PREEMPT realtime patch and system drivers. Fail-safe system software start up with two OS images (active and fault-back) Power fail-safe, self-monitoring and error correcting file system. Secure boot (Chain-of-trust).
Cybersecurity	Conforming to IACS UR E27 Connections to untrusted networks may require additional equipment or security counter-measures not included in the product.
System configuration	On-device web-based configuration (WebConfig). System information. Simplified update procedures (no special tools, same for OS and firmware). User access management (Multiuser access), rights and credentials. Network configuration of the build-in 4 port managed switch (VLAN). IPv4 and IPv6 support (static/dynamic). Network Time protocol support as Client. Discover the device via hostname (mDNS services). Device configuration backup and restore.
System network protocols	Network Time Protocol (NTP), server and client. Dynamic Host Configuration Protocol (DHCP), client.
Programming	
PLC run-time	CODESYS V3 runtime: CODESYS V3.5 SP 20 Patch 4 (updated regularly). iE 250 LAND / MARINE (CODESYS Single Core support), iE 250 PLC (CODESYS Multi Core support).
Programming languages	IEC61131-3: LD, SFC, FBD, ST (CODESYS V3.5 SP18+ IDE).
Visualisation	CODESYS webvisualisation (Option). WEB-Visu rendering for display port.
Application protocols	Ethernet: OPC UA Server OPC UA Client via Single License (CODESYS Store) Modbus TCP Server (CODESYS licence included) Modbus TCP Client (CODESYS licence included) PROFINET V2.3 Class A RT CONTROLLER (CODESYS licence included) PROFINET V2.3 Class A RT DEVICE (CODESYS licence included) OPC UA Server (Open62541 - DEIF component) Modbus TCP Server (libModbus - DEIF component) Modbus TCP Client (libModbus - DEIF component) Fieldbuses: EtherCAT master(CODESYS licence included)

Category	Specification
	CANOpen Client (CODESYS licence included) CANOpen Server (CODESYS licence included) CAN Layer II (via CODESYS library) J1939 (CODESYS licence included) Modbus RTU Client (CODESYS licence included) Modbus RTU Server (CODESYS licence included)

2.5 iE 7 display

2.5.1 Terminal connections

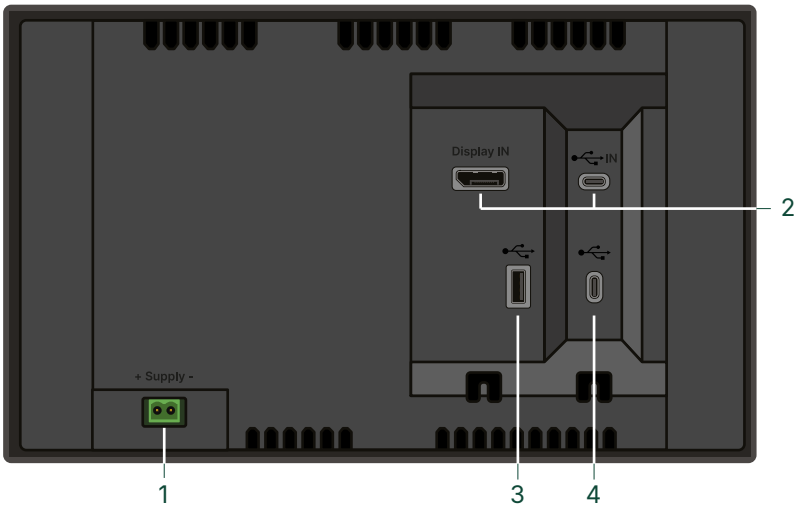

No.	Function	Notes
1	Power supply	1 Power supply (DC+/-)
2	DisplayPort USB IN	Connection to base-mounted controller. USB 2.0 host (type C)
3	USB	USB 2.0 host (type A)
4	USB	USB 2.0 host (type C)

2.5.2 Electrical specifications

Power supply	
Input voltage	Nominal voltage: 12 V DC or 24 V DC (Operation range: 6.5 to 36 V DC) Power up at 8 V Operation down to 6.5 V at 15 W Operation down to 6.9 V at 28 W
Voltage withstand	Reverse polarity
Power supply drop-out immunity	0 V DC for 50 ms (coming from more than 6.5 V DC) at 15 W
Power supply load dump protection	Load dump protected according to ISO16750-2 test A
Power consumption	15 W typical 28 W maximum

Battery voltage measurement	
Accuracy	± 0.8 V within 8 to 32 V DC, ± 0.5 V within 8 to 32 V DC @ 20 °C

2.5.3 Communication specifications

Communication specifications	
DisplayPort *	Connection to base-mounted controller.
USB IN *	Connection to base-mounted controller. USB 2.0 (type C).

Communication specifications

USB hub Type A	For future use.
----------------	-----------------

USB hub Type C	For future use.
----------------	-----------------

NOTE * Both DisplayPort and USB IN are required for communication and control to the controller.

2.6 Measurement Input Output module (MIO2.1)

2.6.1 About

The Measurement Input and Output module (MIO2.1) is an add-on module for the iE 250. It features 8 bi-directional digital terminals, allowing smart flexibility where you can use them for what you need.

AC measurements

The module measures the voltage and current on one side of a breaker, and the voltage on the other side. The hardware module responds when the measurements exceed the AC alarm parameters.

The module provides robust frequency detection in environments with electrical noise. It allows extended measurement bandwidth up to 40 times the nominal frequency. It includes a configurable 4th current measurement.

Additional features

- 8 Digital input channels.
- 8 Digital bi-directional channels.
- Analogue Tacho (MPU/N/NPN/PNP) input.

2.6.2 Terminal connections

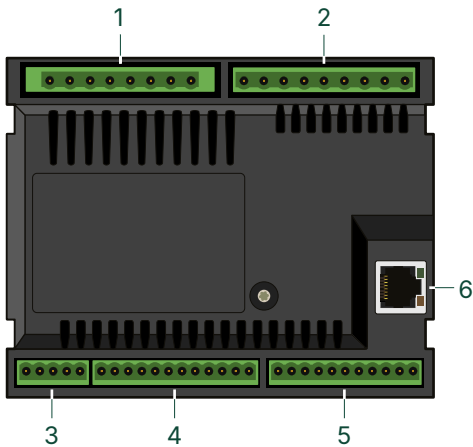

No.	Function	Notes
1	AC current	A-side: L1 (S1,S2) L2 (S1,S2) L3 (S1,S2) A-side or B-side: L4 (S1,S2)
2	AC voltage	A-side: N, L1, L2, L3 B-side: N, L1, L2, L3
3	Analogue outputs	AO1 (+/-) AO2 (+/-)
4	D+ and Digital bi-directional channels	D+ E-stop power cut-off 8 Bi-directional configurable channels
5	Digital input channels and Tacho	8 Digital inputs Tacho
6	EtherCAT	Connection to extension racks

2.6.3 Electrical specifications

All AC measurement specifications are within the reference conditions, unless otherwise stated.

Voltage measurements	
Nominal value (Un)	100 to 690 V AC, phase-to-phase
Reference range	30 to 931.5 V AC
Measurement range	5.0 to 931.5 V AC, phase-to-phase; Truncation: 2 V AC
Accuracy	5.0 to 931.5 V AC: $\pm 0.5\%$ or ± 0.5 V AC (whichever is greater) (Class 5.0)
UL/cUL Listed	600 V AC phase-phase
Consumption	Maximum 0.25 VA/phase
Voltage withstand	Un + 35 % continuously Un + 45 % for 10 seconds

Current measurements	
Nominal value (IN)	1 or 5 A AC from current transformer
Measurement range	0.005 to 20.0 A AC, Truncation: 4 mA AC
Accuracy	0.005 to 20.0 A AC: $\pm 0.5\%$ or ± 5 mA AC (whichever is greater) (Class 0.005)
UL/cUL Listed	From listed or R/C (XODW2.8) current transformers 1 or 5 A AC
Consumption	Maximum 0.3 VA/phase
Current withstand	10 A AC continuous 20 A AC for 1 minute 75 A AC for 10 seconds 250 A AC for 1 second

Frequency measurements	
Nominal value	50 Hz or 60 Hz
Reference range	45 to 66 Hz
Measurement range	10 to 75 Hz
System frequencies	Accuracy: 10 to 75 Hz ± 5 mHz, within the temperature operating range.
Phase frequencies	Accuracy: 10 to 75 Hz ± 10 mHz, within the temperature operating range.

Phase angle (voltage) measurement	
Measurement range	-179.9 to 180°
Accuracy	-179.9 to 180°: 0.2°, within the temperature operating range

Power measurement	
Accuracy	$\pm 0.5\%$ of measured value or $\pm 0.5\%$ of $U_n \cdot I_n$, whichever is greater, within the current measurement range (Class 0.5)

AC Measurement temperature and accuracy	
AC Measurement reference range	-20 to 55 °C (-4 to 131 °F)
Temperature-dependent accuracy outside the reference range	Voltage: Additional: $\pm 0.05\%$, or ± 0.05 V AC per 10 °C (18 °F) (whichever is greater)

AC Measurement temperature and accuracy

Current: Additional: $\pm 0.05\%$, or ± 0.5 mA AC per $10\text{ }^{\circ}\text{C}$ ($18\text{ }^{\circ}\text{F}$) (whichever is greater)
Power: Additional: $\pm 0.05\%$, or $\pm 0.05\%$ of $U_n \cdot I_N$ per $10\text{ }^{\circ}\text{C}$ ($18\text{ }^{\circ}\text{F}$) (whichever is greater)

Digital input channels

8 individual input channels with configurable function.

- Digital input (sourcing) (negative switching)
- Digital input (sinking) (positive switching)

Current or negative source (contact cleaning): Initial 10 mA, continuous 2 mA.

D+

Excitation current	210 mA, 12 V 105 mA, 24 V
Charging fail threshold	6 V
E-stop power cut-off	An e-stop on terminal 46 cuts the power to the D+ terminal.

Tacho

Voltage input range	± 1 to 70 Vp
W	8 to 36 V
Frequency input range	10 to 10 kHz
Frequency measurement tolerance	1 % of reading
Wire break detection	Yes

Digital bi-directional channels

8 bi-directional digital channels with configurable function.

All channels in one electric group.

Configurable as input or output channels.

Modes:

- Disabled
- Digital input (sourcing) (negative switching)
- Digital output (sourcing)
- Digital output (sourcing) with wire break detection

Digital input	0 to 24 V DC Current source (contact cleaning): Initial 10 mA, continuous 2 mA
Digital output	Supply voltage: 12 to 24 V (operating range 6.5 to 28 V DC) <ul style="list-style-type: none">• DIO channels 9 to 12 supply on terminal 46 DC (+) (optional: E-stop power cut-off)• DIO channels 13 to 16 supply on terminal 52 Output current: 2 A DC inrush and 0.5 A continuous (maximum 2 A continuous for all channels)

Analogue outputs

Output types	DC output or PWM
Minimum load resistance	500 Ω (Ohm) or 20 mA

Analogue output AO1	
DC voltage output range	-10.5 to 10.5 V DC
CODESYS controllable	-10.5 to 10.5 V DC
PWM output voltage	Default 6 V, configurable in platform level via EtherCAT in the range 1 to 10.5 V
PWM frequency range	1 to 2500 Hz \pm 25 Hz
PWM duty cycle resolution	12 bits (4096 steps)
Accuracy	Accuracy: \pm 1 % of setting

Analogue output AO2	
DC voltage output range	-10.5 to 10.5 V DC
CODESYS controllable	-10.5 to 10.5 V
PWM output voltage	Default 6 V, configurable in platform level via EtherCAT in the range 1 to 10.5 V
PWM frequency range	1 to 2500 Hz \pm 25 Hz
PWM duty cycle resolution	12 bits (4096 steps)
Accuracy	Accuracy: \pm 1 % of setting

2.6.4 Communication specifications

EtherCAT	
EtherCAT communication	RJ45 Use an Ethernet cable that meets or exceeds the SF/UTP CAT5e specifications

2.7 Plug-in module for 8 Digital bi-directional channels (PIM-8DIO)

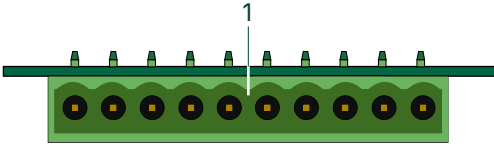

No.	Function	Notes
1	Digital bi-directional channels	COM+ 8 Bi-directional digital channels Ground

Electrical specifications

Digital bi-directional channels

8 bi-directional digital channels with configurable function.
All channels in one electric group.
Configurable as input or output channels.

Modes:

- Disabled
- Digital input (sourcing) (negative switching)
- Digital input (sinking) (positive switching)
- Digital output (sourcing)
- Digital output (sourcing) with wire break detection

Digital input

0 to 24 V DC
Current source (contact cleaning): Initial 10 mA, continuous 2 mA

Digital output

Supply voltage: 12 to 24 V (operating range 6.5 to 28 V DC)
Output current:
Up to 0.5 A (maximum 1 A for all 4 channels)
2 A DC inrush and 0.5 A continuous (maximum 2 A for continuous for all channels)

2.8 Plug-in module for 4 Analogue bi-directional channels (PIM-4AIO)

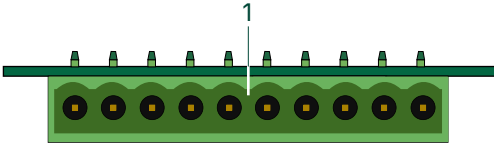

No.	Function	Notes
1	Analogue bi-directional channels	4 Analogue bi-directional channels Ground

Electrical specifications

Analogue bi-directional channels	
4 individual channels (isolated group) with configurable function. Configurable as input or output channels. Galvanic separation to CPU All channels in one electric group	
Input channels	
Digital input	0 to 24 V DC with common threshold 4 V
Resistor measurement	Range: 0 to 1 M Ω Accuracy 0 to 80 Ω : $\pm 1\%$ $\pm 0.5\ \Omega$ 80 to 200 Ω : $\pm 0.4\%$ 200 Ω to 10 k Ω : $\pm 0.4\%$ 10 to 20 k Ω : $\pm 0.5\%$ 20 to 200 k Ω : $\pm 1.5\%$ 200 to 1000 k Ω : $\pm 12\%$
Voltage input	0 to 10 V DC (16-bit sigma delta) Accuracy: 0.5 % of full scale over the operating temperature range. Input impedance: 200 k Ω
Current input	0 to 20 mA (16-bit sigma delta) Accuracy: 0.6 % of full scale over the operating temperature range.
Output channels	
Voltage output	0 to 10 V DC (13-bit resolution) Accuracy: 0.5 % of full scale over the operating temperature range.
Current output	0 to 20 mA (13-bit resolution) Accuracy: 0.6 % of full scale over the operating temperature range. Maximum 2 channels can be selected as current output (internal power limitation)

2.9 Accessories

2.9.1 DIN rail clamps

These are supplied with the base-mounted version.

Category	Specification
DIN rail	35
Type	E/NS 35 N BK - End bracket

2.9.2 USB type A to C cable

The USB cable is necessary for control between the display and base-mounted controller.

This is supplied with the iE 7 display.

Category	Specification
Cable type	USB type A to type C cable.
USB	USB 2.0
Length	3.0 m (9.85 ft)

2.9.3 DisplayPort cable

The DisplayPort cable is necessary for visual HMI between the display and base-mounted controller.

This is supplied with the iE 7 display.

Category	Specification
Cable type	VESA DisplayPort compliant cable.
Length	3.0 m (9.85 ft)

2.9.4 Ethernet cable

The Ethernet cable from DEIF meets the technical specifications below.

Category	Specification
Cable type	Shielded patch cable SF/UTP CAT5e
Temperature	Fixed installation: -40 to 80 °C (-40 to 176 °F) Flexible installation: -20 to 80 °C (-4 to 176 °F)
Minimum bending radius (recommended)	Fixed installation: 25 mm (1 in) Flexible installation: 50 mm (2 in)
Length	2 m (6.6 ft)
Weight	~110 g (4 oz)

2.10 Approvals

Standards
CE
UKCA
UL/cUL Listed to - UL/ULC6200:2019 1.ed. Controllers for Use in Power Production

PLC certificates	Cybersecurity IACS UR E27
ABS	Yes
BV	Yes
DNV	Yes
LR	Yes



More information

See Approvals/certifications for the most recent certificates www.deif.com/documentation/ie-250-plc/.

2.11 Cybersecurity

Category	Specification
Cybersecurity	Certified to IACS UR E27 *

NOTE * Connections to untrusted networks may require additional equipment or security counter-measures not included in the product.

3. Application development

3.1 IEC61131-3 programming

Application Development

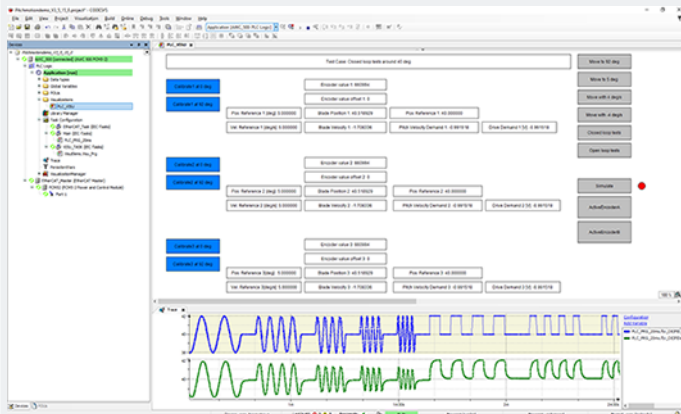

iE 250 / 350 / 650 PLC software



IEC61131-3 PLC-programmed based on CODESYS V3 Programming languages:

- Sequential Function Chart (SFC)
- Function Block Diagram (FBD)
- Structured Text (ST)
- Ladder Diagram (LD)
- Multi-language help in Chinese, German and English
- Programmed via Ethernet connection (TCP/IP)
- Download of boot projects and source code
- Integrated PLC and task configuration
- Web visualisation on PanelPC or remote via Secure communication (HTTPS)
- Online debugging and sampling
- Trace-integrated simulation

- CODESYS V3.5 IDE
- DEIF iE x50 CODESYS TSP (Target Support Package) with EtherCAT device description files.

3.2 Supported software features

Software	PLC Linux SDK	PLC CODESYS (with Web visualization)
PLC runtime	-	CODESYS V3.5 SP20 Patch 4
Programming		
IEC61131-3	-	LD, SFC, FBD, CFC, ST
	-	CODESYS V3.5 SP20 Patch 4 IDE
Network protocols		
	Network Time Protocol (NTP) or Precision Time Protocol (PTP), client	
	Dynamic Host Configuration Protocol (DHCP), client	
Visualisation		
	HTML5/Javascript via build-in webservers	CODESYS Web visualisation
System Configuration		
	Web based system configuration for IP address (static/dynamic), system information.	
Device handling	See Communication protocols	CODESYS Device handling (EtherCAT Master, CANOpen Manager, Modbus TCP)
Configuration		
Visualisation designer		CODESYS V3.5 visualisation

Software	PLC Linux SDK	PLC CODESYS (with Web visualization)
Scope/trace		Scope/trace
HMI visualisation tool		CODESYS web visualisation
		Panel PC and remote HMI client (communication via HTTPS) Requires: Browser with HTML5/JavaScript support, such as Chrome, Firefox, Safari, Edge, and more (Kiosk mode possible)

Communication protocols

Software	PLC Linux SDK	PLC CODESYS (with Web visualization)
OPC UA Server	-	Yes - OPC UA Server (CODESYS) open62541 (DEIF)
OPC UA Client	-	Yes - OPC UA Client (CODESYS)
Modbus TCP Server	-	Yes - Modbus TCP Server (CODESYS) libModbus (DEIF)
Modbus TCP Client	-	Yes - Modbus TCP Server (CODESYS) libModbus (DEIF)
Modbus RTU Master	-	Yes - Modbus TCP Server (CODESYS) libModbus (DEIF)
Modbus RTU Slave	-	Yes - Modbus RTU Slave (CODESYS)
EtherCAT Master	-	Yes - EtherCAT Master (CODESYS)
CAN Layer II	-	Yes - via CODESYS library
CANopen Master	-	Yes - CANopen Master (CODESYS)
CANopen Slave	-	Yes - CANopen Slave (CODESYS)
PROFINET V2.3 Class A RT CONTROLLER	-	Yes - (CODESYS)
PROFINET V2.3 Class A RT DEVICE	-	Yes - (CODESYS)
Others		On request or via CODESYS Single License

4. Legal information

4.1 Disclaimer and copyright

Open source software

This product contains open source software licensed under, for example, the GNU General Public License (GNU GPL) and GNU Lesser General Public License (GNU LGPL). The source code for this software can be obtained by contacting DEIF at support@deif.com. DEIF reserves the right to charge for the cost of the service.

General warranty

The warranty period for the purchased product is defined in the contract and order acknowledgement. In general, DEIF's Terms and Conditions of Sale and Delivery apply.

The product continuously monitors the operating temperature and stores this information in a log file on the device. DEIF uses this information for service purpose and to validate if issues with the product are covered by the warranty.

The software packages supplied are believed to be of the highest quality. Due to the nature of the software development process, it is possible that there are hidden defects in the software which may affect its use, or the operation of any software or device developed with this software package.

DEIF does not undertake responsibility for determining whether this package is suitable for the application, nor for ensuring the correct operation of the application software and hardware.

The warranty does not cover product wear parts, such as:

- Internal flash disc
- If applicable, SD card (purchased separately)
- Replaceable coil-cell battery, used for the real-time clock (available as a spare part)

Use of Non-cybersecurity certified software (Developer edition firmware)

The Developer/Engineering Edition Firmware (identified as *iE x50 UPE vX* software bundle) is intended solely for advanced development purposes.

It permits users to edit or remove embedded cybersecurity rules and policies, perform customisations, run own applications or integrate 3rd party software, that inhibits DEIF to take responsibility for the software to comply with product relevant cybersecurity standards.

To the extent that the customer modifies or disables such cybersecurity features, DEIF shall bear no responsibility or liability for any resulting security vulnerabilities, unauthorized external access, data breaches, or any other interference or damages affecting the project. The customer assumes full responsibility for the consequences of any such modifications and has the responsibility for relevant cybersecurity certifications.

Trademarks

DEIF and the DEIF logo are trademarks of DEIF A/S.

BELDEN is a trademark of BELDEN INC.

Adobe®, Acrobat®, and Reader® are either registered trademarks or trademarks of Adobe Systems Incorporated in the United States and/or other countries.

CANopen® is a registered community trademark of CAN in Automation e.V. (CiA).

SAE J1939® is a registered trademark of SAE International®.

CODESYS® is a trademark of CODESYS GmbH.

EtherCAT®, EtherCAT P®, Safety over EtherCAT®, are trademarks or registered trademarks, licensed by Beckhoff Automation GmbH, Germany.

VESA® and DisplayPort® are registered trademarks of Video Electronics Standards Association (VESA®) in the United States and other countries.

Google® and Google Chrome® are registered trademarks of Google LLC.

Linux® is a registered trademark of Linus Torvalds in the U.S. and other countries.

Modbus® is a registered trademark of Schneider Automation Inc.

Torx®, Torx Plus® are trademarks or registered trademarks of Acument Intellectual Properties, LLC in the United States or other countries.

Windows® is a registered trademark of Microsoft Corporation in the United States and other countries.

All trademarks are the properties of their respective owners.

Copyright

© Copyright DEIF A/S. All rights reserved.

Disclaimer

DEIF A/S reserves the right to change any of the contents of this document without prior notice.

The English version of this document always contains the most recent and up-to-date information about the product. DEIF does not take responsibility for the accuracy of translations, and translations might not be updated at the same time as the English document. If there is a discrepancy, the English version prevails.