

# PPU 300

Paralleling and Protection Unit

Data sheet

4921240563-V



Improve  
Tomorrow

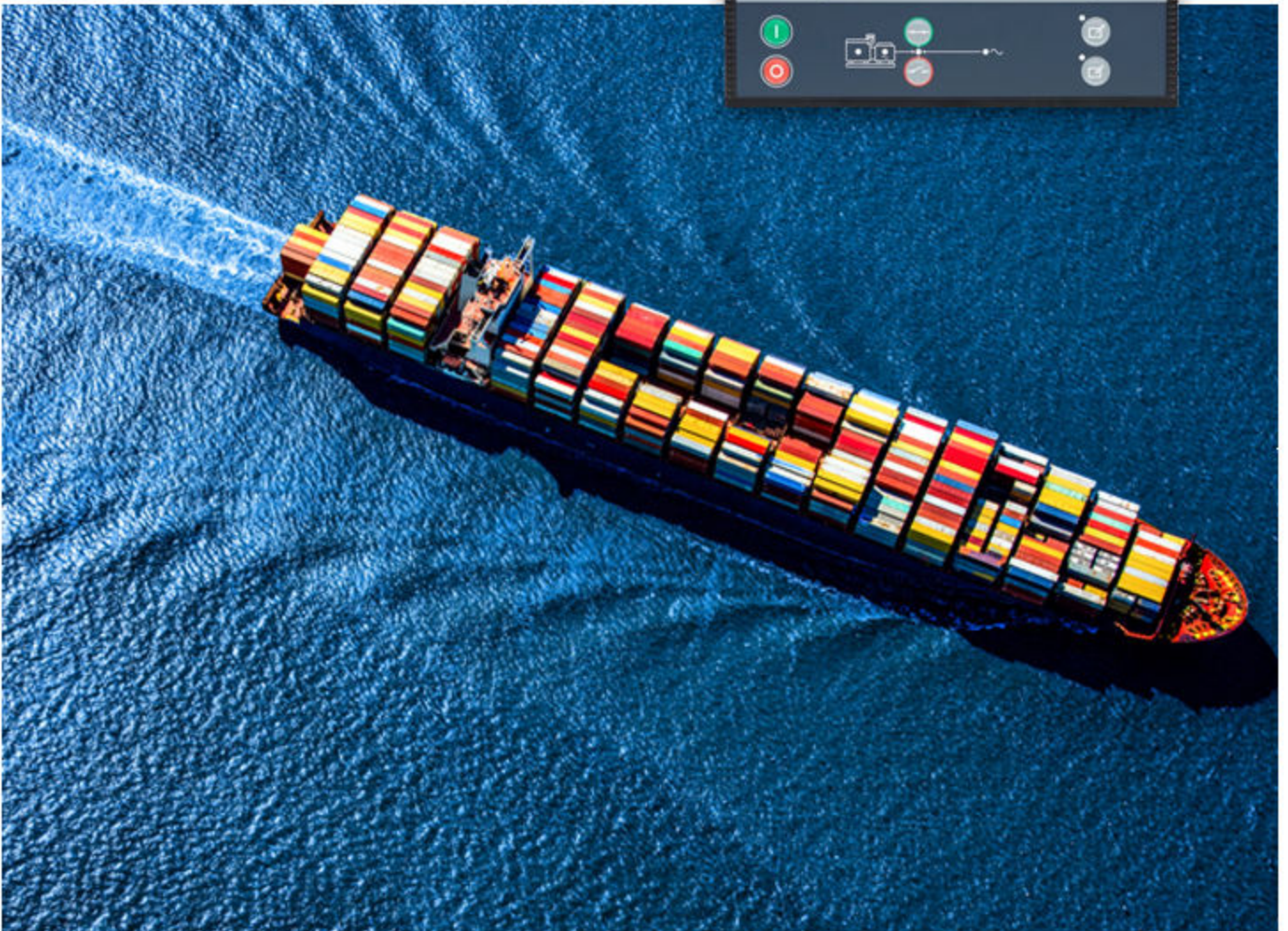

## 1. Product description

<b>1.1 About</b> .....	<b>4</b>
<b>1.2 Software versions</b> .....	<b>4</b>
<b>1.3 Functions and features</b> .....	<b>5</b>
1.3.1 General functions and features.....	5
1.3.2 Alarm functions.....	8
<b>1.4 Alarms and protections</b> .....	<b>8</b>
1.4.1 Alternating current (AC) protections.....	8
1.4.2 General controller alarms.....	11

## 2. Controller types

<b>2.1 About the controller types</b> .....	<b>15</b>
<b>2.2 About the hardware modules</b> .....	<b>15</b>
<b>2.3 About the display unit DU 300</b> .....	<b>16</b>
<b>2.4 GENSET controller</b> .....	<b>16</b>
2.4.1 Functions.....	17
2.4.2 Alarms and protections.....	18
<b>2.5 HYBRID controller</b> .....	<b>19</b>
2.5.1 Functions.....	20
2.5.2 Alarms and protections.....	20
<b>2.6 BUS TIE breaker controller</b> .....	<b>21</b>
2.6.1 Functions.....	22
2.6.2 Alarms and protections.....	22
<b>2.7 SHAFT generator controller</b> .....	<b>22</b>
2.7.1 Functions.....	23
2.7.2 Alarms and protections.....	23
<b>2.8 SHORE connection controller</b> .....	<b>24</b>
2.8.1 Functions.....	25
2.8.2 Alarms and protections.....	25

## 3. Technical specifications

<b>3.1 General technical specifications</b> .....	<b>26</b>
3.1.1 Electrical specifications.....	26
3.1.2 Mechanical specifications.....	26
3.1.3 Environment specifications.....	27
3.1.4 Approvals.....	27
<b>3.2 Rack specifications</b> .....	<b>27</b>
3.2.1 Rack R4.1.....	27
3.2.2 Rack R7.1.....	28
<b>3.3 Hardware module specifications</b> .....	<b>29</b>
3.3.1 Power supply module PSM3.1 (Controller).....	29
3.3.2 Power supply module PSM3.2 (Extension).....	31
3.3.3 Alternating current module ACM3.1.....	33
3.3.4 Differential current module ACM3.2.....	34
3.3.5 Engine interface module EIM3.1.....	36
3.3.6 Governor and AVR module GAM3.1.....	39
3.3.7 Governor and AVR module GAM3.2.....	41
3.3.8 Input/output module IOM3.1.....	43
3.3.9 Input/output module IOM3.2.....	44
3.3.10 Input/output module IOM3.3.....	46
3.3.11 Input/output module IOM3.4.....	48

3.3.12 Processor and communication module PCM3.1.....	50
3.3.13 Blind module.....	51
<b>3.4 Display unit DU 300 specifications.....</b>	<b>52</b>
3.4.1 Display unit DU 300.....	52
<b>3.5 Accessory specifications.....</b>	<b>53</b>
3.5.1 Ethernet cable.....	53
<b>4. Ordering</b>	
<b>4.1 PPU 300 controller ordering.....</b>	<b>54</b>
<b>4.2 Extension rack ordering.....</b>	<b>55</b>
<b>4.3 Modules for controller configuration.....</b>	<b>56</b>
<b>5. Legal information</b>	
<b>5.1 Disclaimer and copyright.....</b>	<b>58</b>

# 1. Product description

## 1.1 About

The PPU 300 Paralleling and Protection Unit is a highly configurable controller designed for marine use. The controller contains the functions required to protect and control a generator or inverter and its breaker (specifically, a diesel generator, an inverter with power source, a shaft generator, a shore connection, or a bus tie breaker). You can connect up to 32 controllers to create one system, with load sharing sections.

The PPU 300 can be ordered with a PLC environment (CODESYS) as an add-on option. CODESYS can be used to extend the controller functionality and/or create custom CODESYS projects for the controller.

Typically, CODESYS or an operator will send commands to the PPU 300 to close or open the breaker. CODESYS or an operator can also send commands to start or stop the generator or inverter, change the regulation mode, and change the regulation set points.

You can also use an alternative PLC to send commands to the PPU 300.

AC measurements can be configured with average filters for use on noisy or oscillating systems. This is only for the displayed values. All calculations and protections continue to use the actual values. \*

The controller display unit can have push-buttons for the operator to change the controller mode, close and open the breaker, and start and stop a generator or inverter. The colour graphic screen shows status and info messages. Visual synchronisation screen shows the synchronisation state and values. The screen also allows access to live data, and alarm management. With the right authorisation, the operator can also check and/or change the input/output and parameter configuration. The light indicators of the display unit show the system status.

Each controller includes processors and high-speed internal communication. This provides fast protection functions.

The controller design is modular, and hardware modules may be replaced or added in the field.

PICUS is a proprietary, free PC software interface to the controller. The designer can use PICUS to create a flexible application diagram for the system, and configure the inputs, outputs, and parameters for all the controllers in the system. PICUS also offers system emulation, supervision, management of permissions, backups, trending, and firmware updates.

The network communication can be configured for IP address settings and for type of Ethernet port and connection node.

Engine communication with CAN bus J1939 can be configured to communicate with an ECU.



### More information

See the **Engine interface communication** manual for supported engines, protocols, and functions.

**NOTE** \* Measurement averaging is not enabled in the default configuration. It may not be allowed for some Maritime classification approval societies.



### More information

You can find additional technical documentation at [www.deif.com/documentation/ppu-300/](http://www.deif.com/documentation/ppu-300/)

## 1.2 Software versions

The information in this document relates to software versions:

Software	Details	Version
PCM APPL	Controller application	1.0.26.x
DU APPL	Display unit application	1.0.22.x
PICUS	PC software	1.0.23.x

## 1.3 Functions and features

### 1.3.1 General functions and features

#### General functions for all PPU 300 controllers

	Functions
<b>Modular and configurable design</b>	<ul style="list-style-type: none"> <li>• Compact, all-in-one controller <ul style="list-style-type: none"> <li>◦ All necessary 3-phase measurements</li> </ul> </li> <li>• Optional I/O extension rack</li> <li>• Configurable hardware modules (printed circuit boards) <ul style="list-style-type: none"> <li>◦ Placement flexibility in the controller</li> <li>◦ Remove, replace, or add on-site</li> <li>◦ Automatically recognised</li> <li>◦ Customisable arrangement (during ordering and/or on-site)</li> </ul> </li> <li>• Configurable input and output functions (digital and analogue) <ul style="list-style-type: none"> <li>◦ Digital input functions: Commands from operators or 3rd party equipment, changing configuration, operating information</li> <li>◦ Digital output functions: Alarm status, commands to 3rd party equipment, operating information</li> <li>◦ Analogue input functions: External set points, operating information, supervised binary inputs</li> <li>◦ Analogue output functions: Regulation *, operating information</li> </ul> </li> <li>• Up to 4 sets of nominal settings <ul style="list-style-type: none"> <li>◦ Select a different set of nominal settings at any time</li> </ul> </li> <li>• Configurable parameters for controller functions</li> <li>• Power transformer settings for AC measurements (ACM3.1) <ul style="list-style-type: none"> <li>◦ Configurable step-up or step-down settings</li> </ul> </li> <li>• Several ways to start controller sequences <ul style="list-style-type: none"> <li>◦ Automatically, display unit, digital input, PICUS, Modbus, and/or CustomLogic</li> </ul> </li> </ul>
<b>Plug and play</b>	<ul style="list-style-type: none"> <li>• Automatic network configuration (uses static IPv6)</li> <li>• Default parameter and input-output configuration for each controller type</li> <li>• Automatic date and time synchronisation between all controllers in the system</li> <li>• NTP time synchronisation with NTP servers</li> </ul>
<b>Display unit</b>	<ul style="list-style-type: none"> <li>• Up to 2 display units (with interlock) per controller</li> <li>• Intuitive, one-touch operator-initiated sequences</li> <li>• 5-inch colour graphic display <ul style="list-style-type: none"> <li>◦ Initial configuration</li> <li>◦ Status and info messages</li> <li>◦ Live data monitoring and alarm management</li> <li>◦ Visual synchronisation</li> <li>◦ Configure live data screens</li> <li>◦ Tier 4 support and after-treatment dashboard</li> <li>◦ Input, output, and parameter configuration</li> </ul> </li> </ul>

	Functions
	<ul style="list-style-type: none"> <li>◦ View/configure counters</li> <li>◦ View/configure tags</li> <li>◦ Log, info and tools</li> <li>◦ Show or hide Tags for Alarm pop-up, alarms, log, and parameters.</li> <li>◦ Manage backup and restore</li> <li>◦ Soft keys, and virtual keyboard</li> <li>◦ Context-sensitive help</li> <li>◦ Configurable brightness</li> <li>• Supports multiple languages <ul style="list-style-type: none"> <li>◦ American English</li> <li>◦ British English</li> <li>◦ Chinese</li> <li>◦ French</li> <li>◦ German</li> <li>◦ Russian</li> <li>◦ Spanish</li> </ul> </li> </ul>
<b>Advanced troubleshooting</b>	<ul style="list-style-type: none"> <li>• Controller hardware self-test</li> <li>• Event and alarm log, with real-time clock</li> <li>• Access to 24-hour service and support</li> </ul>
<b>PICUS</b>	<ul style="list-style-type: none"> <li>• Free-of-charge PC software to connect to one or more controllers</li> <li>• Single-line diagram tool for design, configuration and broadcast</li> <li>• Manage permissions and passwords (groups and users)</li> <li>• For each controller: <ul style="list-style-type: none"> <li>◦ Configure controller inputs, outputs, and parameters</li> <li>◦ Manage alarms</li> <li>◦ View status, live data, and log</li> <li>◦ Manage backup and restore</li> <li>◦ Use offline projects to view or edit a controller configuration <ul style="list-style-type: none"> <li>◦ Projects can be restored or broadcast.</li> </ul> </li> </ul> </li> <li>• System emulation: <ul style="list-style-type: none"> <li>◦ Safely mimic the environment that the controller connects to (loads, inputs, and failure scenarios)</li> <li>◦ Test the application, get approvals, minimise site time, optimise training</li> </ul> </li> <li>• System supervision</li> <li>• Input / output status <ul style="list-style-type: none"> <li>◦ See an overview for all input and output values for the controller, extension racks, or ECUs.</li> </ul> </li> <li>• Trending <ul style="list-style-type: none"> <li>◦ Record and save operational values over a period of time</li> <li>◦ Export recorded trace values to a .csv file</li> </ul> </li> <li>• Tags <ul style="list-style-type: none"> <li>◦ Show or hide Tags for Alarm pop-up, alarms, log, parameters, and reports.</li> </ul> </li> <li>• Manage controller and display unit software</li> <li>• Supports multiple controller languages</li> </ul>
<b>CustomLogic</b>	<ul style="list-style-type: none"> <li>• User-friendly logic configuration tool, based on ladder logic and function blocks</li> <li>• Up to 20 selectable input events and 20 output commands per controller</li> <li>• Inter-controller communication</li> </ul>

	Functions
	<ul style="list-style-type: none"> <li>◦ Up to 16 outputs per controller</li> <li>◦ Up to 16 inputs from each controller in the system</li> <li>• Up to 20 Modbus signals (inputs and/or outputs) per controller</li> </ul>
<b>CODESYS</b>	<ul style="list-style-type: none"> <li>• Option: Extended controller functionality with soft PLC</li> <li>• Custom information pop-up messages and status texts. <ul style="list-style-type: none"> <li>◦ Provide better user experience by delivering messaging and status information from the CODESYS application.</li> </ul> </li> <li>• View CODESYS license key information in PICUS or display</li> </ul>
<b>Communication</b>	<ul style="list-style-type: none"> <li>• Static Internet Protocol version 6 (IPv6)</li> <li>• Configurable Internet Protocol version 4 (IPv4)</li> <li>• Configurable Ethernet port settings on PCM3.1</li> <li>• Multi-master system. All vital data is broadcast to all controllers: <ul style="list-style-type: none"> <li>◦ Each controller performs all calculations, then acts accordingly</li> <li>◦ Load sharing communication</li> </ul> </li> <li>• DEIF internal network <ul style="list-style-type: none"> <li>◦ Controller display unit</li> <li>◦ PICUS</li> <li>◦ Other controllers</li> </ul> </li> <li>• Internal communication <ul style="list-style-type: none"> <li>◦ Extension rack(s)</li> </ul> </li> <li>• External network <ul style="list-style-type: none"> <li>◦ PICUS</li> <li>◦ Modbus</li> </ul> </li> <li>• Controllers connected in a ring for communication redundancy: <ul style="list-style-type: none"> <li>◦ If there is a failure: Communication path changed within 100 milliseconds.</li> </ul> </li> <li>• CAN bus communication to an ECU: <ul style="list-style-type: none"> <li>◦ Generic J1939.</li> <li>◦ Supported engine protocols.</li> </ul> </li> <li>• Authentication (other equipment cannot disrupt communication)</li> <li>• Password protection <ul style="list-style-type: none"> <li>◦ Customisable permission levels</li> </ul> </li> </ul>
<b>Modbus</b>	<ul style="list-style-type: none"> <li>• Supports multiple Modbus protocols <ul style="list-style-type: none"> <li>◦ Standard protocol: Modbus TCP/IP</li> <li>◦ Supports use and creation of custom protocols</li> <li>◦ Import and export Modbus protocols</li> </ul> </li> <li>• Convert data units and scaling</li> <li>• Configure Modbus server settings</li> </ul>
<b>Breaker control</b>	<ul style="list-style-type: none"> <li>• Synchronisation and breaker closing <ul style="list-style-type: none"> <li>◦ Dynamic synchronisation: With slip frequency, for fast load acceptance</li> <li>◦ Static synchronisation: Phases match kept within a phase window **</li> </ul> </li> <li>• De-load before opening</li> <li>• Automatic synchronisation and de-loading</li> <li>• Operator-initiated synchronisation and de-loading possible</li> <li>• Breaker types (with configurable parameters) <ul style="list-style-type: none"> <li>◦ Pulse breaker, Compact breaker, Continuous breaker</li> </ul> </li> <li>• Breaker position detection and alarms</li> <li>• Attempt to open breaker even with a position failure detection</li> </ul>

	Functions
<b>Redundancy</b>	<ul style="list-style-type: none"> <li>• True multi-master control</li> <li>• Busbar can have a ring connection</li> <li>• DEIF network ring connection</li> <li>• Internal communication ring connection</li> <li>• Controller commands and operation using the display unit, inputs, PICUS, and/or Modbus</li> <li>• Redundant breaker feedback on bus tie breakers and externally controlled breakers</li> </ul>
<b>Additional hardware/software features</b>	<ul style="list-style-type: none"> <li>• Hardware/software features: Power supply voltage measurement diode offset</li> <li>• Relay configuration (function, coil state)</li> <li>• Analogue input sensor failure (below and above range)</li> <li>• Analogue input pre-configured curves, plus up to 20 customisable curves</li> <li>• Analogue output pre-configured curves, plus up to 20 customisable curves</li> <li>• AC measurements can be configured with average filters for use on noisy or oscillating systems for displayed information. Controller data and calculations are not affected. Actual values are always used for the calculations and protections. *** <ul style="list-style-type: none"> <li>◦ No filters, or average over a selected time. <ul style="list-style-type: none"> <li>◦ 200 or 800 milliseconds</li> </ul> </li> </ul> </li> <li>• Configurable Idle run (supported engines only) <ul style="list-style-type: none"> <li>◦ Protect the engine with additional warm-up or cooldown periods</li> </ul> </li> <li>• Display unit lamp test</li> <li>• CPU load overview <ul style="list-style-type: none"> <li>◦ Currently</li> <li>◦ Average over 10 seconds</li> <li>◦ Average over 1 minute</li> <li>◦ Average over 10 minutes</li> </ul> </li> </ul>

**NOTE** \* Only for the **GENSET**, and **HYBRID** controllers.

**NOTE** \*\* Static synchronisation cannot be performed in non-regulating controller types where regulation is required.

**NOTE** \*\*\* Measurement averaging is not enabled in the default configuration. It may not be allowed for some Maritime classification approval societies.

### 1.3.2 Alarm functions

- Pre-defined alarms, alarm actions, and alarm inhibits.
- Alarm management: Alarm state, Acknowledgement, Latching, Resetting, Shelving, Out of service.
- Customised alarm parameters: Enable, set point, delay, reset hysteresis, auto acknowledge, trigger level, suppress action.
- Three customisable inhibits per controller.
- Configurable horn output.
- Alarm test.



#### More information

See the chapter **Alarms** in the **Designer's handbook** for more information about alarms.

## 1.4 Alarms and protections

### 1.4.1 Alternating current (AC) protections

The controllers include the following alternating current (AC) protections, according to IEEE Std. C37.2<sup>TM</sup>-2008.

The *operate time* is defined in IEC 447-05-05 (from the instant when the need for the protection arises, to when the controller output has responded). For each protection, the *operate time* is given for the minimum user-defined time delay.

All AC alarms are available on all controllers, unless specifically stated in the notes.

Controller type	[Source]	[Busbar]
GENSET	Generator	Busbar
HYBRID	Inverter	Busbar
SHAFT generator	Generator	Busbar
SHORE connection	Shore busbar	Ship busbar
BUS TIE breaker	Busbar A	Busbar B

### AC protections for the [source]

Protection	Alarms	IEC symbol (IEC 60617)	ANSI (IEEE C37.2)	Operate time	Based on	Note
Over-voltage	2	U>	59	< 100 ms	The highest phase-to-phase (or phase-to-neutral) voltage	1
Under-voltage	2	U<	27	< 100 ms	The lowest phase-to-phase (or phase-to-neutral) voltage	1
Voltage unbalance (voltage asymmetry)	1	UUB>	47	< 200 ms *	The highest difference between any of the 3 phase-to-phase (or phase-to-neutral) voltage true RMS values, and the average value	1
Negative sequence voltage	1		47	< 200 ms *	The estimated phase-to-neutral voltage phasors	2
Zero sequence voltage	1		59U <sub>0</sub>	< 200 ms *	The estimated phase-to-neutral voltage phasors	2
Over-current	2	3I>	50TD	< 100 ms	The highest phase current true RMS values	1
Fast over-current (short circuit)	2	3I>>>	50/50TD	< 50 ms	The highest phase current true RMS values	1
Current unbalance **	2	IUB>	46	< 200 ms *	The highest difference between any of the 3 phase currents and the average, or nominal value	1
Inverse time over-current	1	It>	51	-	The highest phase current true RMS values, based on IEC 60255 part 151	1
Directional over-current	2 ****		67	< 100 ms	The highest phase current true RMS value, with the direction from the active power	1
Negative sequence current	1		46	< 200 ms *	The estimated current phasors	3
Zero sequence current	1		51I <sub>0</sub>	< 200 ms *	The estimated current phasors	3
Over-frequency	2	f>	81O	< 100 ms	The lowest fundamental frequency of a phase voltage	1
Under-frequency	2	f<	81U	< 100 ms	The highest fundamental frequency of a phase voltage	1
Overload ***	2	P>	32	< 100 ms	The active power (all phases)	1

Protection	Alarms	IEC symbol (IEC 60617)	ANSI (IEEE C37.2)	Operate time	Based on	Note
Reverse power ***	2	P<	32R	< 100 ms	The active power (all phases)	1
Overload reverse power	2		32R	< 100 ms	The active power (all phases)	6
Over-excitation (reactive power export)	2	Q>	400	< 100 ms	The reactive power (all phases)	1
Under-excitation (reactive power import/loss of excitation)	2	Q<	40U	< 100 ms	The reactive power (all phases)	1
Synchronisation check (including blackout close)	Not an alarm	-	25	-	The frequency difference, the voltage difference, and the phase angle across the breaker	1
Stabilized differential current protection (ACM3.2 differential current module required)	1	Id>	87G	< 40ms (when the measured value increases from zero to two times the alarm set point)	<p>The RMS value of the fundamental frequency part of the sum/ difference of the neutral side and consumer side currents, dependent on the operating characteristic</p> <p>Operate value accuracy: Based on the largest secondary current</p> <ul style="list-style-type: none"> <li><math>I_{\text{secondary}} \leq 20 \text{ A}</math>: 1.5 % of <math>I_{\text{secondary}}</math> or <math>\pm 15 \text{ mA}</math></li> <li><math>20 \text{ A} &lt; I_{\text{secondary}} \leq 250 \text{ A}</math>: 2.5 % of <math>I_{\text{secondary}}</math></li> </ul>	5
High set differential current protection (ACM3.2 differential current module required)	1	Id>>	87G	< 40 ms (when the measured value increases from zero to two times the alarm set point)	<p>The RMS value of the fundamental frequency part of the sum/ difference of the neutral side and consumer side currents, independent of the restraint current</p> <p>Operate value accuracy: Based on the largest secondary current</p> <ul style="list-style-type: none"> <li><math>I_{\text{secondary}} \leq 20 \text{ A}</math>: 1.5 % of <math>I_{\text{secondary}}</math> or <math>\pm 15 \text{ mA}</math></li> <li><math>20 \text{ A} &lt; I_{\text{secondary}} \leq 250 \text{ A}</math>: 2.5 % of <math>I_{\text{secondary}}</math></li> </ul>	5

Note 1: All controller types.

Note 2: Only **GENSET** and **HYBRID** controller.

Note 3: Only **GENSET**, **HYBRID** and **BUS TIE breaker** controllers.

Note 4: Only **GENSET**, **HYBRID**, **SHAFT generator** and **SHORE connection** controllers.

Note 5: Only **GENSET**, **HYBRID** and **SHAFT generator** controllers with ACM3.2 installed.

Note 6: Only **HYBRID** controllers for overload protection.

- NOTE** \* These operate times include the minimum user-defined delay of 100 ms.  
 \*\* Available as both current unbalance average calculation or current unbalance nominal calculation.  
 \*\*\* On **BUS TIE** breaker controller, Overload is Power export and Reverse power is Power import.  
 \*\*\*\* On **BUS TIE** breaker controller, there are 4 alarms.

### AC protections for the [busbar]

Protection	Alarms	IEC symbol (IEC 60617)	ANSI (IEEE C37.2)	Operate time	Based on	Note
Over-voltage	2	U>	59	< 50 ms	The highest phase-to-neutral (or phase-to-phase) voltage	1
Under-voltage	2	U<	27	< 50 ms	The lowest phase-to-neutral (or phase-to-phase) voltage	1
Voltage unbalance (voltage asymmetry)	1	UUB>	47	< 200 ms *	The highest difference between any of the 3 phase-to-phase (or phase-to-neutral) voltage true RMS values, and the average value	1
Over-frequency	2	f>	81O	< 50 ms	The lowest fundamental frequency of a phase voltage	1
Under-frequency	2	f<	81U	< 50 ms	The highest fundamental frequency of a phase voltage	1

Note 1: All controller types.

**NOTE** \* This operate time includes the minimum user-defined delay of 100 ms.

### Other AC protections

Protection	Alarms	IEC symbol (IEC 60617)	ANSI (IEEE C37.2)	Operate time	Based on
Lockout relay	1		86	-	Protected equipment
Earth inverse time over-current	1		51G	-	The current RMS value, measured by the 4th current measurement on ACM3.1, filtered to attenuate the third harmonic (at least 18 dB)
Neutral inverse time over-current	1		51N	-	The current RMS value, measured by the 4th current measurement on ACM3.1

## 1.4.2 General controller alarms

### All controllers

Each controller includes the AC protections, the alarms listed here, and the alarms specific to the controller type.

[\*B] refers to the breaker that the controller controls. For example, GB for a **GENSET** controller.

# represents a number that is related to that type of alarm.

	Protections	Alarms
<b>Breaker</b>	[*B] closing failure	1 *
	[*B] opening failure	1 *
	[*B] position failure	1 *
	[*B] configuration failure	1 *
	[*B] synchronisation failure	1 *
	[*B] de-load failure	1 *
	[*B] tripped (external)	1 *
	[*B] short circuit	1 *
	[*B] vector mismatch alarm	1 *
<b>Communication</b>	Modbus communication timeout	1
	DEIF network redundancy broken	1
	DEIF network top ring redundancy broken	1
	No NTP server time synchronisation	1
	No NTP server(s) connected	1
	NTP server # could not connect	2
	NTP server # is not responding	2
	Fieldbus conflict	1
	Fieldbus connection missing	1
	ECU communication failure	1
<b>Synchronisation</b>	Phase sequence error [Source]	1
	Phase sequence error [Busbar]	1
<b>System monitoring</b>	Breaker # feedback position failure	1
	Live power detected (Emulation)	1
	Emulation disabled (Live power)	1
	Application initialisation error	1
	Controller not part of system	1
	Single-line missing/none active	1
	Missing any controller	1
	Missing all controllers	1
	Missing controllers	1
	System not OK	1
	Critical process error	1
	Different single-line configurations	1
	Controller type mismatch	1
	Controller ID not configured	1
	Duplicate controller ID	1
Missing controller ID #	1 for each controller (up to 12)	
Configuration update delayed	1	

	Protections	Alarms
<b>Inputs</b>	Digital inputs	Up to 50 customisable alarms per controller
	Analogue inputs	Up to 200 customisable alarms per controller
<b>General</b>	PSM3.1 # supply voltage high	1
	PSM3.1 # supply voltage low	1
	PCM clock battery failure	1
	Controller temperature too high	1
	Required I/O card(s) not found	1
	Software mismatch on hardware module(s)	1

### ACM measurement error protections

	Protections
<b>ACM measurement error</b>	[Source] L1-L2-L3 wire break *
	[Busbar] L1-L2-L3 wire break *
	[Source] L1 wire break *
	[Source] L2 wire break *
	[Source] L3 wire break *
	[Busbar] L1 wire break *
	[Busbar] L2 wire break *
	[Busbar] L3 wire break *
	ACM 1 protections not running
	ACM 1 data is missing

**NOTE** \* These alarms only work when the breaker is closed. These alarms are only on **GENSET, SHAFT generator, SHORE connection, and BUS TIE breaker** controllers.

The following table shows the names for [Source] and [Busbar] for the controllers with ACM measurement error protections.

Controller type	[Source]	[Busbar]
<b>GENSET</b>	Generator	Busbar
<b>HYBRID</b>	Inverter	Busbar
<b>SHAFT generator</b>	Generator	Busbar
<b>SHORE connection</b>	Shore busbar	Ship busbar
<b>BUS TIE breaker</b>	Busbar A	Busbar B

### Optional alarms for the EIM3.1 hardware

	Protections	Alarms
<b>Power supply</b>	EIM3.1 # supply voltage high	1
	EIM3.1 # supply voltage low or missing	1
<b>Wire break</b>	EIM3.1 # relay 4 wire break	1
<b>Standalone **</b>	EIM3.1 # hardware revision does not support stand-alone	1

	Protections	Alarms
Safety shutdown	EIM3.1 # safety shutdown configuration is not correct	1
	EIM3.1 # safety shutdown still has control	1

**NOTE** \*\* Standalone is only available on the first installed EIM3.1 hardware module.

#### Optional alarms for GAM3.2 hardware

	Protections	Alarms
General	GAM3.2 # status not OK	1
	GAM3.2 # supply voltage high	1
	GAM3.2 # supply voltage low or missing	1

#### Optional alarms for the extension rack

	Protections	Alarms
General	PSM3.2 # status not OK	1
	PSM3.2 # supply voltage high	1
	PSM3.2 # supply voltage low	1

## 2. Controller types

### 2.1 About the controller types

Each controller is assigned a type from the factory.

The assigned controller type from the factory can be either:

- Generator controller (**GENSET** controller, standard)
- Generator controller with CODESYS (**GENSET** controller, with built-in PLC)
- **HYBRID** controller

The **GENSET** controller type can be changed from the Application drawing (Single-line diagram) for the associated controller ID. \*

Possible controller types selectable from a **GENSET** controller with or without CODESYS:

Controller type	Controls and protects
<b>GENSET</b> controller	An engine and generator, and the generator breaker.
<b>BUS TIE breaker</b> controller	One bus tie breaker.
<b>SHAFT generator</b> controller	The system when a shaft generator is connected.
<b>SHORE connection</b> controller	The system and the shore connection breaker, when a shore connection is connected.

### 2.2 About the hardware modules

The hardware modules are printed circuit boards that slot in to either a rack R7.1 or rack R4.1. Depending on the type of module, they can provide AC or other measurements, inputs, outputs and give communication indication.

Example rack R7.1

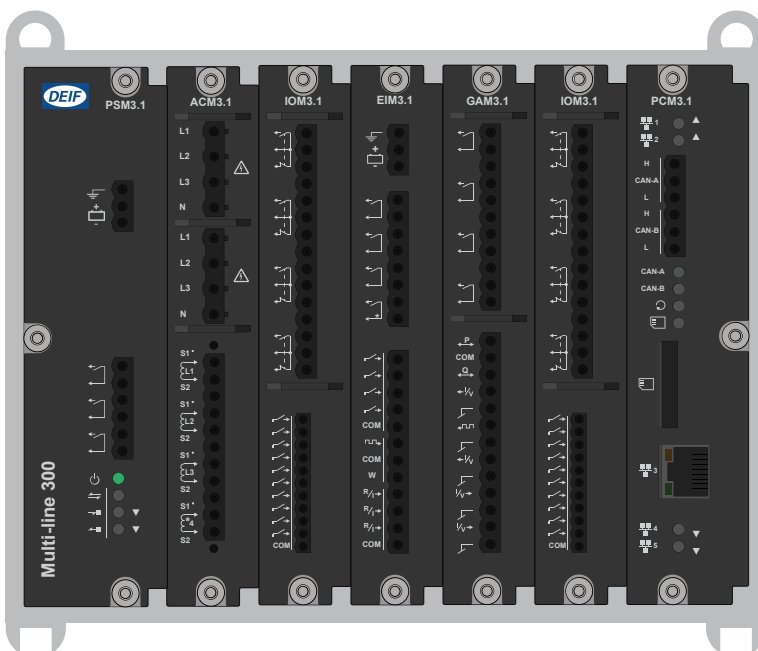

Example rack R4.1

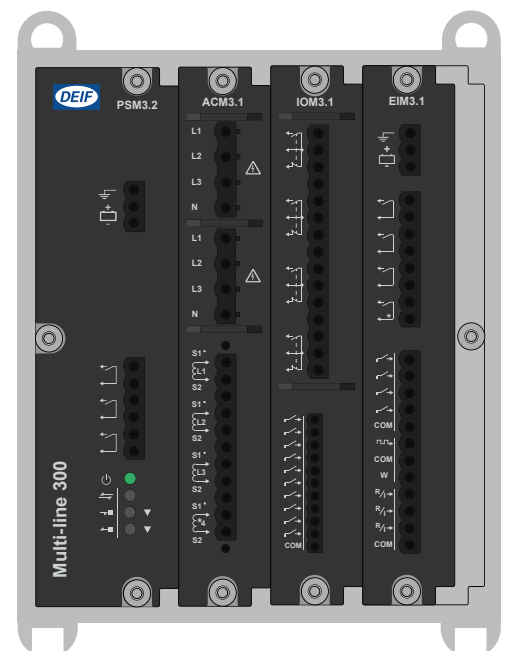

The hardware modules feature:

- Placement flexibility in the rack.

- Add, replace, or remove on-site.
- Automatically recognised.
- Configurable input and output functions (digital and analogue):
  - Digital input functions: Commands from operators or 3rd party equipment, changing configuration, operating information.
  - Digital output functions: Alarm status, commands to 3rd party equipment, operating information.
  - Analogue input functions: External set points, operating information, supervised binary inputs.
  - Analogue output functions: Regulation \*, operating information.

**NOTE** \* Only available on certain types of controller.

All slots must be covered during operation and blind modules can be used to cover unused slots.

## 2.3 About the display unit DU 300

The controller can run with or without a display, but we recommend to use the DU 300 display unit. Alternatively, you can use a touch display from the DEIF AGI 400 series.

The display unit is the operator's interface to the controller. The 5-inch colour graphic display shows real-time operating information, and it supports all languages with UTF-8 fonts.

The power supply terminals include circuit protection against load dump transients and JEM177 surge transients (rugged design).



### 1. Top part

- Same for all DU 300 display units

### 2. Bottom strip with control

- Different for each controller type (shown for GENSET controller)

## 2.4 About the GENSET controller

A **GENSET** controller controls and protects a prime mover (for example, a diesel engine) and generator, as well as the generator breaker. A system can include a number of **GENSET** controllers.

Each **GENSET** controller can connect up to three non-essential load groups (NEL).

## Example application with non-essential loads

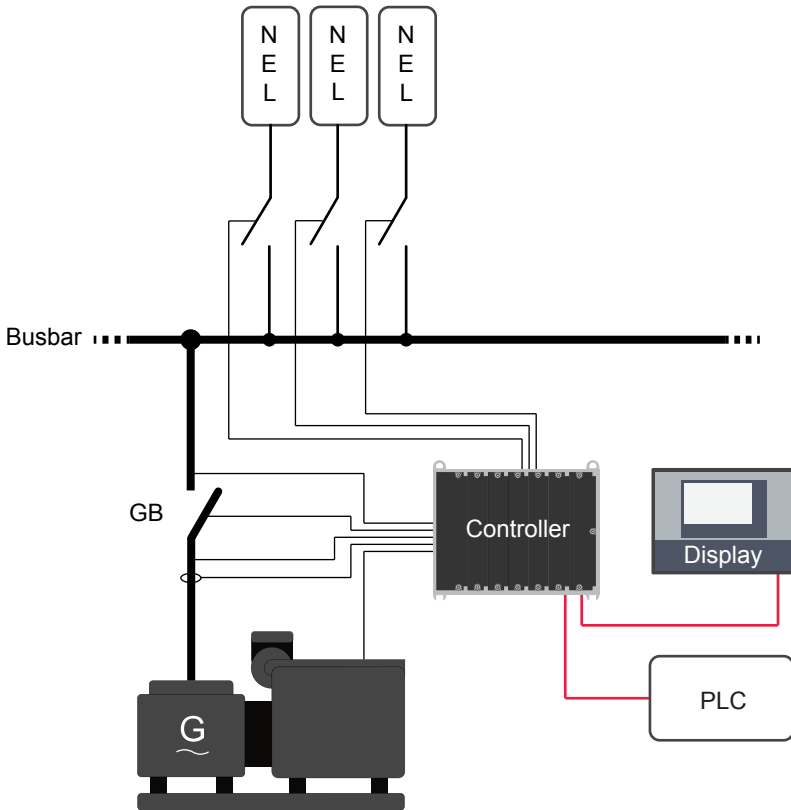

## PPU 300 Display unit bottom strip with control (DG + CB CTRL)

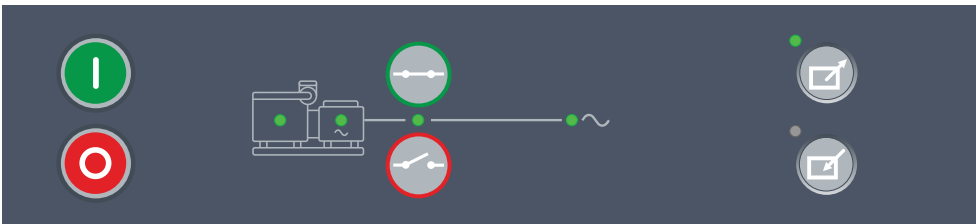

### 2.4.1 Functions

	Functions
<b>Pre-programmed sequences</b>	<ul style="list-style-type: none"> <li>• Genset start and stop sequences</li> <li>• Breaker sequences</li> <li>• Generator breaker blackout close</li> </ul>
<b>Regulation</b>	<ul style="list-style-type: none"> <li>• PID regulators for analogue outputs</li> <li>• P regulators for relay outputs</li> <li>• Set point selection using digital input, Modbus, and/or CustomLogic or CODESYS</li> <li>• Governor <ul style="list-style-type: none"> <li>◦ Active power load sharing</li> <li>◦ Fixed frequency</li> <li>◦ Fixed active power</li> <li>◦ Frequency droop</li> </ul> </li> <li>• AVR <ul style="list-style-type: none"> <li>◦ Reactive power load sharing</li> <li>◦ Fixed voltage</li> <li>◦ Fixed reactive power</li> </ul> </li> </ul>

	Functions
	<ul style="list-style-type: none"> <li>◦ Fixed cos phi</li> <li>◦ Voltage droop</li> <li>• External set point from analogue input or Modbus</li> <li>• Configurable power ramp up/down</li> <li>• Three sets of temperature-dependent power derate settings</li> </ul>
<b>4th current</b>	<ul style="list-style-type: none"> <li>• Measurement for earth or neutral protections</li> </ul>
<b>Control modes</b>	<ul style="list-style-type: none"> <li>• Local mode <ul style="list-style-type: none"> <li>◦ Generator start/stop with the start/stop push-buttons</li> <li>◦ The breaker is controlled by the close/open push-buttons</li> </ul> </li> <li>• Remote mode <ul style="list-style-type: none"> <li>◦ Generator and breaker controlled from a PLC (or integrated CODESYS) combined with parameter settings</li> </ul> </li> </ul>

## 2.4.2 Alarms and protections

These alarms are in addition to the [AC protections](#) and [general alarms](#) for PPU 300 controllers.

	Alarms and protections
<b>Engine</b>	Emergency stop
	Overspeed (2 alarms)
	Under-speed (2 alarms)
	Crank failure
	Primary running feedback failure
	Start failure
	Stop failure
	Engine stop (external)
	Engine start (external)
	Start enable removed during start
	Total running hours notification
	Trip running hours notification
	Magnetic pickup wire break
	<b>Generator</b>
<b>Regulation</b>	GOV regulation error
	GOV regulation mode not selected
	GOV stand-alone configuration error*
	GOV relay setup incomplete
	P load sharing failure
	AVR regulation error
	AVR regulation mode not selected
	AVR stand-alone configuration error*
	AVR relay setup incomplete
	Q load sharing failure

	Alarms and protections
<b>Non-essential load (NEL)</b>	<ul style="list-style-type: none"> <li>Up to 3 non-essential loads per controller</li> <li>Can connect each controller to the same 3 non-essential load breakers</li> </ul>
	NEL # over-current (1 alarm for each non-essential load)
	NEL # under-frequency (1 alarm for each non-essential load)
	NEL # overload 1 and 2 (2 alarms for each non-essential load)
	NEL # reactive overload (1 alarm for each non-essential load)
<b>Other</b>	Trip AVR output not configured

**NOTE** \* Only in GAM3.2.

## 2.5 About the HYBRID controller

A **HYBRID** controller controls an inverter with power source, and the inverter breaker. A system can include a number of **HYBRID** controllers.

The **HYBRID** controller only directly controls an inverter and the inverter breaker. It does not control or provide any management of the actual power source, for example a Battery Management System (BMS). The customer must ensure that the necessary management system for the power source is installed and approved, according to the applicable Maritime classification societies.

Each **HYBRID** controller can control up to three non-essential load groups (NEL).

### Example application with non-essential loads

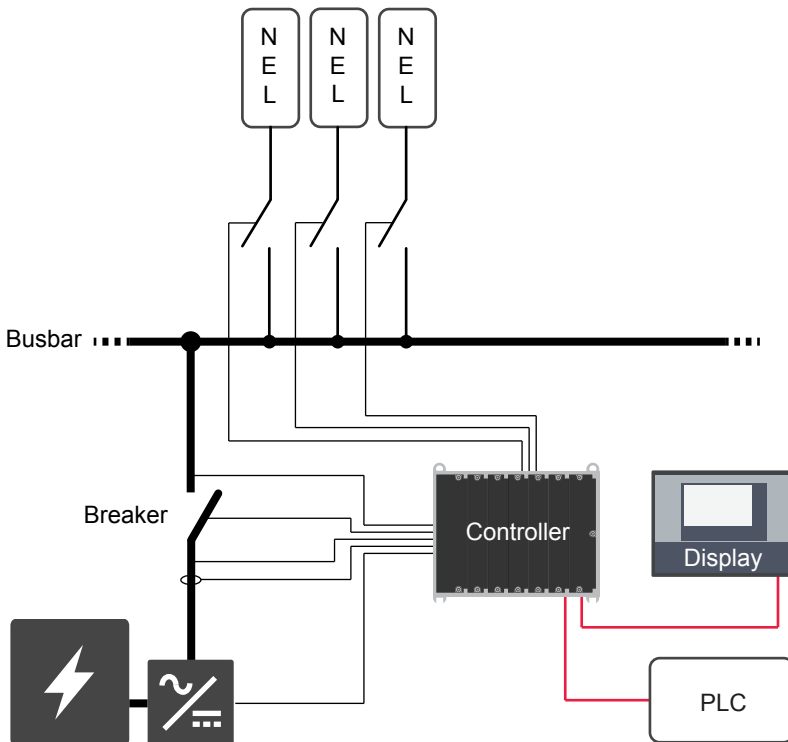

## PPU 300 Display unit bottom strip

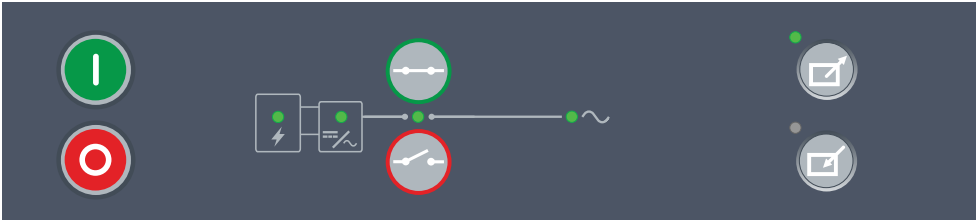

### 2.5.1 Functions

Functions	
<b>Pre-programmed sequences</b>	<ul style="list-style-type: none"> <li>• Inverter start and stop sequences</li> <li>• Breaker sequences</li> <li>• Inverter breaker blackout close</li> </ul>
<b>Inverter modes</b>	<ul style="list-style-type: none"> <li>• Power Take Off (PTO)</li> <li>• Power Take In (PTI)</li> <li>• Standby</li> </ul>
<b>Counters</b>	<ul style="list-style-type: none"> <li>• Display unit counters, to edit or reset: <ul style="list-style-type: none"> <li>◦ Start attempts</li> <li>◦ Running hours (total and trip)</li> <li>◦ Inverter breaker operations and trips</li> <li>◦ Power export (active and reactive)</li> <li>◦ External breaker operations</li> </ul> </li> <li>• Energy counters with configurable digital outputs for external counters</li> </ul>
<b>Control modes</b>	<ul style="list-style-type: none"> <li>• Local mode: <ul style="list-style-type: none"> <li>◦ Inverter start/stop with the start/stop push-buttons</li> <li>◦ The breaker is controlled by the close/open push-buttons</li> </ul> </li> <li>• Remote mode: <ul style="list-style-type: none"> <li>◦ Inverter and breaker controlled from a PLC (or integrated CODESYS) combined with parameter settings</li> </ul> </li> </ul>

### 2.5.2 Alarms and protections

These alarms are in addition to the [AC protections](#) and [general alarms](#) for PPU 300 controllers.

Alarms and protections	
<b>Inverter</b>	Emergency stop
	Start sequence failure
	Stop sequence failure
	Total running hours notification
	Trip running hours notification
	Standby request failure
	Standby acknowledge timeout
	PTI request failure
	PTI acknowledge failure
	PTO request failure
	PTO acknowledge failure

Alarms and protections	
Regulation	GOV regulation error
	GOV regulation mode not selected
	GOV stand-alone configuration error *
	GOV relay setup incomplete
	P load sharing failure
	AVR regulation error
	AVR regulation mode not selected
	AVR stand-alone configuration error *
	AVR relay setup incomplete
	Q load sharing failure
Non-essential load (NEL)	<ul style="list-style-type: none"> <li>Up to 3 non-essential loads per controller</li> <li>Can connect each controller to the same 3 non-essential load breakers</li> </ul>
	NEL # over-current (1 alarm for each non-essential load)
	NEL # under-frequency (1 alarm for each non-essential load)
	NEL # overload 1 and 2 (2 alarms for each non-essential load)
	NEL # reactive overload (1 alarm for each non-essential load)
Other	Trip AVR output not configured

**NOTE** \* Only in GAM3.2.

## 2.6 About the BUS TIE breaker controller

Each **BUS TIE breaker** controller controls one bus tie breaker.

There can be a ring busbar connection.

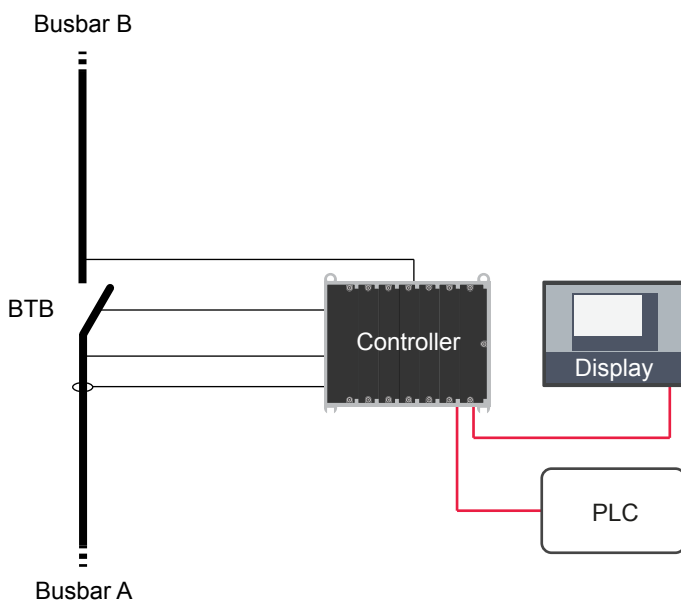

## PPU 300 Display unit bottom strip with control (CB CTRL)

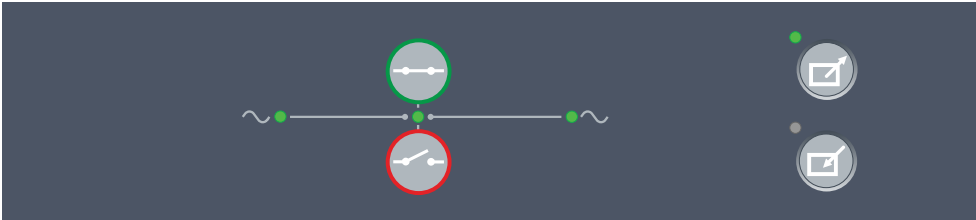

### 2.6.1 Functions

	Functions
<b>Synchronisation and deloading</b>	<ul style="list-style-type: none"> <li>Broadcast the set point for <b>GENSET</b> controllers (busbar A and busbar B sections)</li> </ul>
<b>Counters</b>	<ul style="list-style-type: none"> <li>Display unit counters, to edit or reset: <ul style="list-style-type: none"> <li>Bus tie breaker operations and trips</li> <li>Busbar B energy export/import (active and reactive)</li> <li>Energy differential (active and reactive)</li> <li>External breaker operations</li> </ul> </li> <li>Energy counters with configurable digital outputs (for external counters)</li> </ul>

### 2.6.2 Alarms and protections

All the **BUS TIE breaker** controller alarms are included in the [AC protections](#) and [general alarms](#) for PPU 300 controllers.

## 2.7 About the SHAFT generator controller

A **SHAFT generator** controller controls and protects the system when a shaft generator is connected. The **SHAFT generator** controller also controls and protects the shaft generator breaker.

### Example application with non-essential loads

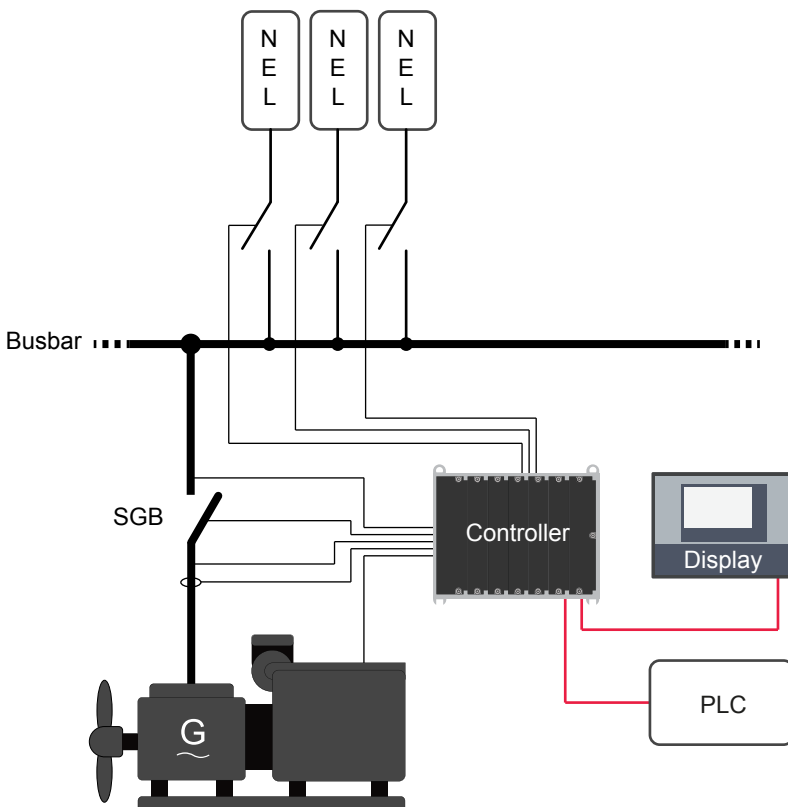

## PPU 300 Display unit bottom strip with control (CB CTRL)

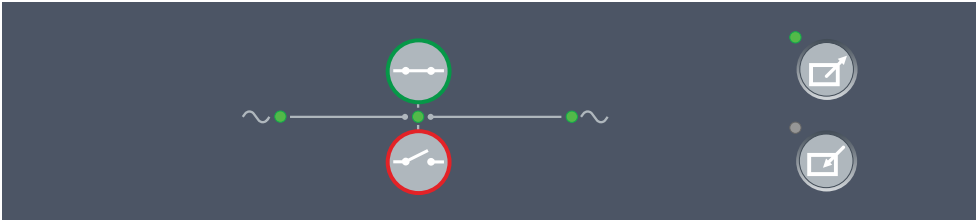

### 2.7.1 Functions

	Functions
<b>Running detection</b>	<ul style="list-style-type: none"> <li>Multiple feedback options: Frequency, MPU/W/NPN/PNP (RPM), Digital input</li> </ul>
<b>Synchronisation and deloading</b>	<ul style="list-style-type: none"> <li>Broadcast the set point for <b>GENSET</b> controllers</li> </ul>
<b>Counters</b>	<ul style="list-style-type: none"> <li>Display unit counters, to edit or reset: <ul style="list-style-type: none"> <li>Running hours (total, and trip)</li> <li>Shaft generator breaker operations and trips</li> <li>Energy export/import (active and reactive)</li> <li>External breaker operations</li> </ul> </li> <li>Energy counters with configurable digital outputs for external counters</li> </ul>
<b>Regulation</b>	<ul style="list-style-type: none"> <li>Regulators for relay outputs and analogue outputs</li> <li>Governor regulation: <ul style="list-style-type: none"> <li>Fixed power</li> <li>Active power load sharing</li> <li>Active power ramp down</li> <li>Frequency-dependent power droop</li> </ul> </li> <li>AVR regulation: <ul style="list-style-type: none"> <li>Reactive power load sharing</li> <li>Fixed reactive power</li> <li>Fixed cos phi</li> <li>Voltage droop</li> </ul> </li> <li>Configurable power ramp up/down</li> </ul>

### 2.7.2 Alarms and protections

These alarms are in addition to the [AC protections](#) and [general alarms](#) for PPU 300 controllers.

	Alarms and protections
<b>Running feedback</b>	Primary running feedback failure
<b>Maximum parallel time</b>	SG-DG maximum parallel time
	SG-SG maximum parallel time
	SG-Hybrid maximum parallel time
<b>Regulation</b>	<ul style="list-style-type: none"> <li>GOV regulation error</li> <li>GOV regulation mode not selected</li> <li>GOV stand-alone configuration error *</li> <li>P load sharing failure</li> <li>AVR regulation error</li> <li>AVR regulation mode not selected</li> </ul>

	Alarms and protections
	<ul style="list-style-type: none"> <li>• AVR stand-alone configuration error *</li> <li>• Q load sharing failure</li> </ul>
<b>Non-essential load (NEL)</b>	<ul style="list-style-type: none"> <li>• Up to 3 non-essential loads per controller</li> <li>• Can connect each controller to the same 3 non-essential load breakers</li> </ul>
	NEL # over-current (1 alarm for each non-essential load)
	NEL # under-frequency (1 alarm for each non-essential load)
	NEL # overload 1 and 2 (2 alarms for each non-essential load)
	NEL # reactive overload (1 alarm for each non-essential load)
<b>Other</b>	Trip AVR output not configured

**NOTE** \* Only in GAM3.2.

## 2.8 SHORE connection controller

When the shore connection is in use, it is normally the ship's only power source. However, the gensets may run in parallel with the shore connection for a limited time.

There is no restriction on the number of **SHORE connection** controllers.

### Example application with non-essential loads

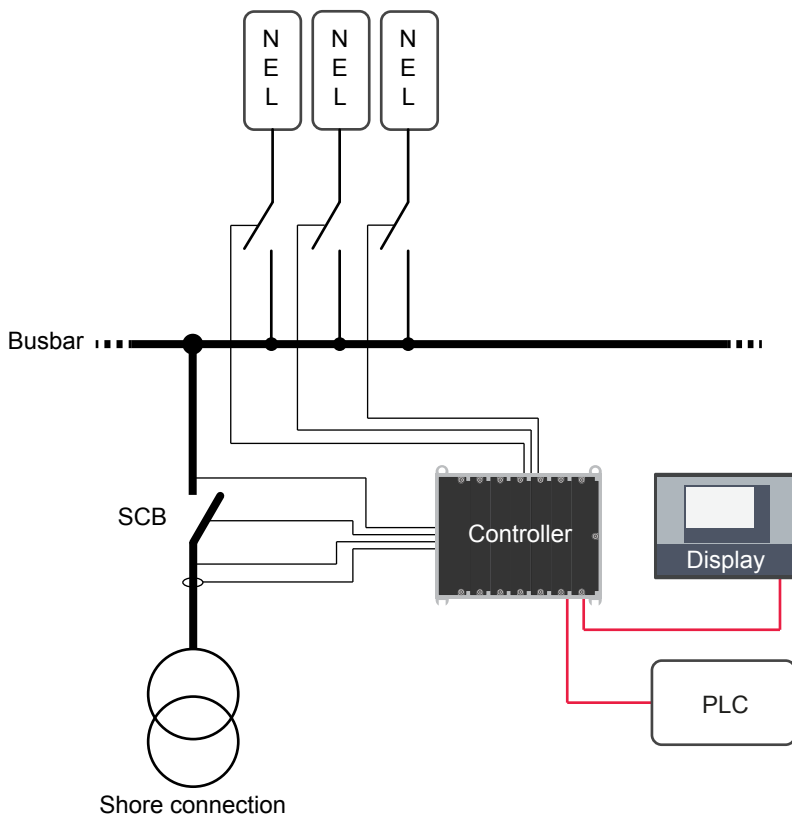

## PPU 300 Display unit bottom strip with control (CB CTRL)

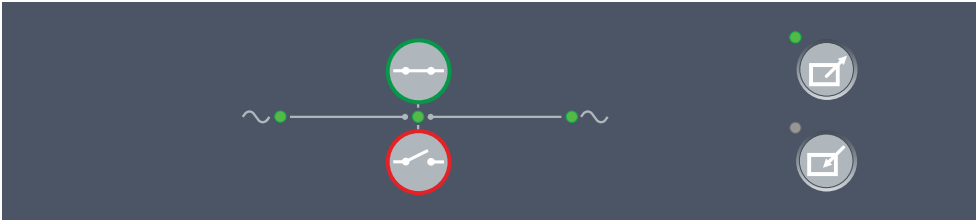

### 2.8.1 Functions

	Functions
<b>Synchronisation and deloading</b>	<ul style="list-style-type: none"> <li>Broadcast the set point for <b>GENSET</b> controllers</li> </ul>
<b>Counters</b>	<ul style="list-style-type: none"> <li>Display unit counters, to edit or reset: <ul style="list-style-type: none"> <li>Shore connection breaker operations and trips</li> <li>Power export/import (active and reactive)</li> <li>External breaker operations</li> </ul> </li> <li>Energy counters with configurable digital outputs for external counters</li> </ul>

### 2.8.2 Alarms and protections

These alarms are in addition to the [AC protections](#) and [general alarms](#) for PPU 300 controllers.

	Alarms and protections
<b>Maximum parallel time</b>	SC-DG maximum parallel time
	SC-SC maximum parallel time
	SC-SG maximum parallel time
	SC-Hybrid maximum parallel time
<b>Non-essential load (NEL)</b>	<ul style="list-style-type: none"> <li>Up to 3 non-essential loads per controller</li> <li>Can connect each controller to the same 3 non-essential load breakers</li> </ul>
	NEL # over-current (1 alarm for each non-essential load)
	NEL # under-frequency (1 alarm for each non-essential load)
	NEL # overload 1 and 2 (2 alarms for each non-essential load)
	NEL # reactive overload (1 alarm for each non-essential load)

## 3. Technical specifications

The general technical specifications apply to all hardware. Refer to the other sections for the specific technical specifications for specific hardware.

The specifications and approvals apply to the rack with all the hardware modules properly installed.

### 3.1 General technical specifications

#### 3.1.1 Electrical specifications

Category	Specification
<b>Safety</b>	EN 61010-1, CAT III, 600V, pollution degree 2 IEC/EN 60255-27, CAT III, 600V, pollution degree 2 UL508 UL6200 CSA C22.2 No. 14-13 CSA C22.2 No. 142 M1987
<b>Electromagnetic compatibility (EMC)</b>	EN 61000-6-3 Residential, commercial and light-industrial environments EN 61000-6-2 Industrial environments IEC/EN 60255-26 IEC 60533 power distribution zone IACS UR E10 power distribution zone for controller rack IEC 60945 for display unit
<b>Load dump</b>	ISO 7637-2 pulse 5a

#### 3.1.2 Mechanical specifications

Category	Specification	
<b>Vibration</b>	Operation	3 to 8 Hz: 17 mm peak-to-peak 8 to 100 Hz: 4 g 100 to 500 Hz: 2 g
	Response	10 to 58.1 Hz: 0.15 mm peak-to-peak 58.1 to 150 Hz: 1 g
	Endurance	10 to 150 Hz: 2 g
	Seismic	3 to 8.15 Hz: 15 mm peak-to-peak 8.15 to 35 Hz: 2 g
	IEC 60068-2-6, IACS UR E10, IEC 60255-21-1 (class 2), IEC 60255-21-3 (class 2)	
<b>Shock (base mounted)</b>	10 g, 11 ms, half sine IEC 60255-21-2 Response class 2 30 g, 11 ms, half sine IEC 60255-21-2 Endurance class 2 50 g, 11 ms, half sine IEC 60068-2-27	
<b>Bump</b>	20 g, 16 ms, half sine IEC 60255-21-2 class 2	
<b>Material</b>	All plastic materials are self-extinguishing according to UL94 (V0)	

**NOTE**  $g$  = gravitational force (g-force).

### 3.1.3 Environment specifications

Category	Specification
Humidity	97 % relative humidity condensing, to IEC 60068-2-30
Operating temperature, rack and modules	-40 to 70 °C (-40 to 158 °F) UL/cUL Listed: maximum surrounding air temperature: 55 °C (131 °F)
Operating temperature, display unit	-20 to 70 °C (-4 to 158 °F) UL/cUL Listed: maximum surrounding air temperature: 55 °C (131 °F)
Storage temperature, rack and modules	-40 to 80 °C (-40 to 176 °F)
Storage temperature, display unit	-30 to 80 °C (-22 to 176 °F)
Operating altitude	Up to 4,000 m (13,123 ft) Refer to the module specifications for information on altitude derating over 2,000 m (6,562 ft)

### 3.1.4 Approvals

These approvals apply to the controller rack (with all the modules properly installed), and to the display unit.

Standards
CE
UL/cUL Listed to UL508 - Industrial Control Equipment, and CSA C22.2 No. 142 M1987 - Process Control Equipment
UL/cUL Recognised to UL6200 - Controls for stationary engine driven assemblies, and CSA C22.2 No. 14-13 - Industrial Control Equipment

**NOTE** For marine approvals, refer to [www.deif.com](http://www.deif.com) for the most recent approvals.

## 3.2 Rack specifications

### 3.2.1 Rack R4.1

#### Rack R4.1 technical specifications

Category	Specification
Ingress protection	IP20 (all slots must have modules or blind modules mounted) according to IEC/EN 60529
UL/cUL Listed	Type Complete Device, Open Type 1
Material	Rack frame: Aluminium
Mounting	Base mount, using four M6 bolts with self-locking washers (or self-locking screws).
	The bolts and self-locking washers (or self-locking screws) are not included with the rack.
	UL/cUL Listed: For use on a flat surface of a type 1 enclosure UL/cUL Listed: To be installed in accordance with the NEC (US) or the CEC (Canada)
Tightening torque	Mounting bolts: 4 N·m (35 lb-in)

### Rack 4.1 dimension and weight specifications

Category	Specification
<b>Dimensions</b>	L 146.1 mm x H 199.9 mm x D 157.5 mm (5.75 in x 7.87 in x 6.20 in) (outer frame, includes cable strain relief plates)
<b>Weight</b>	Without any hardware modules: 994 g (2.2 lb)

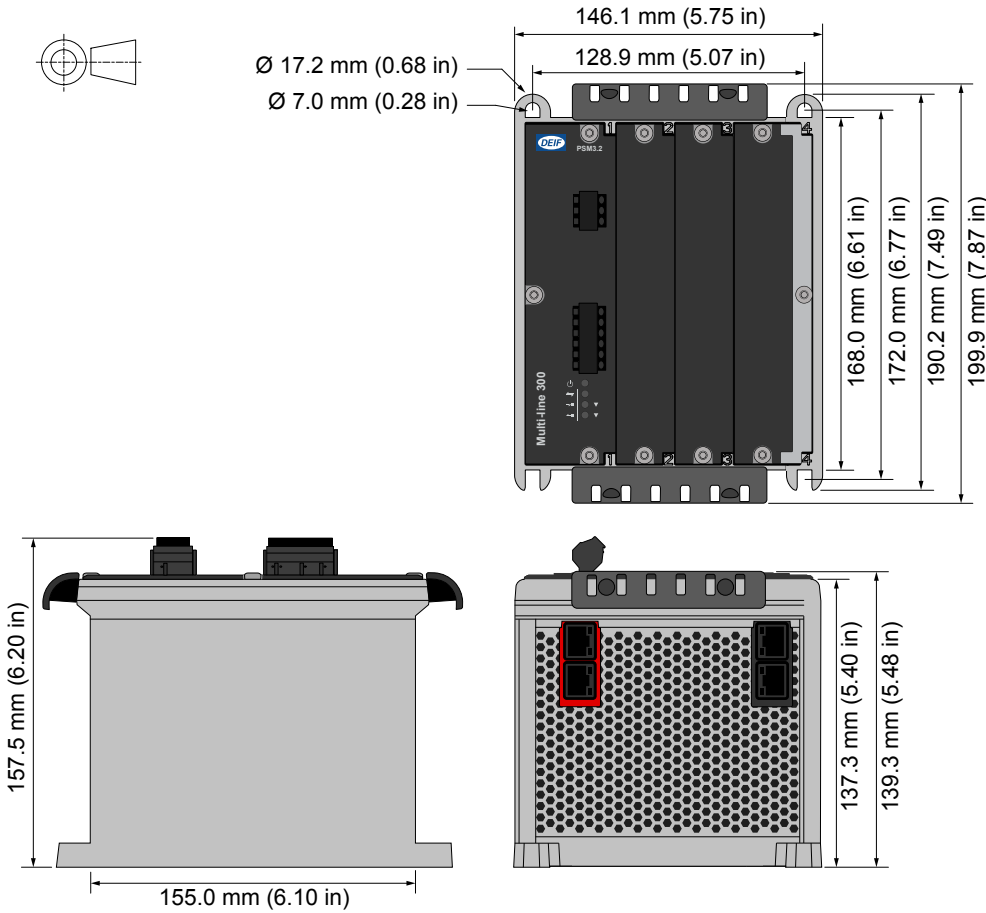

### 3.2.2 Rack R71

#### Rack 7.1 technical specifications

Category	Specification
<b>Ingress protection</b>	IP20 (all slots must have modules or blind modules mounted) according to IEC/EN 60529
<b>UL/cUL Listed</b>	Type Complete Device, Open Type 1
<b>Material</b>	Rack frame: Aluminium
<b>Mounting</b>	<p>Base mount, using four M6 bolts with self-locking washers (or self-locking screws).</p> <p>The bolts and self-locking washers (or self-locking screws) are not included with the rack.</p> <p>UL/cUL Listed: For use on a flat surface of a type 1 enclosure</p> <p>UL/cUL Listed: To be installed in accordance with the NEC (US) or the CEC (Canada)</p>
<b>Tightening torque</b>	Mounting bolts: 4 N·m (35 lb-in)

## Rack 7.1 dimensions and weight specifications

Category	Specification
Dimensions	L 230.1 mm x H 199.9 mm x D 157.5 mm (9.06 in x 7.87 in x 6.20 in) (outer frame, includes cable strain relief plates)
Weight	Without any hardware modules: 1330 g (2.9 lb)

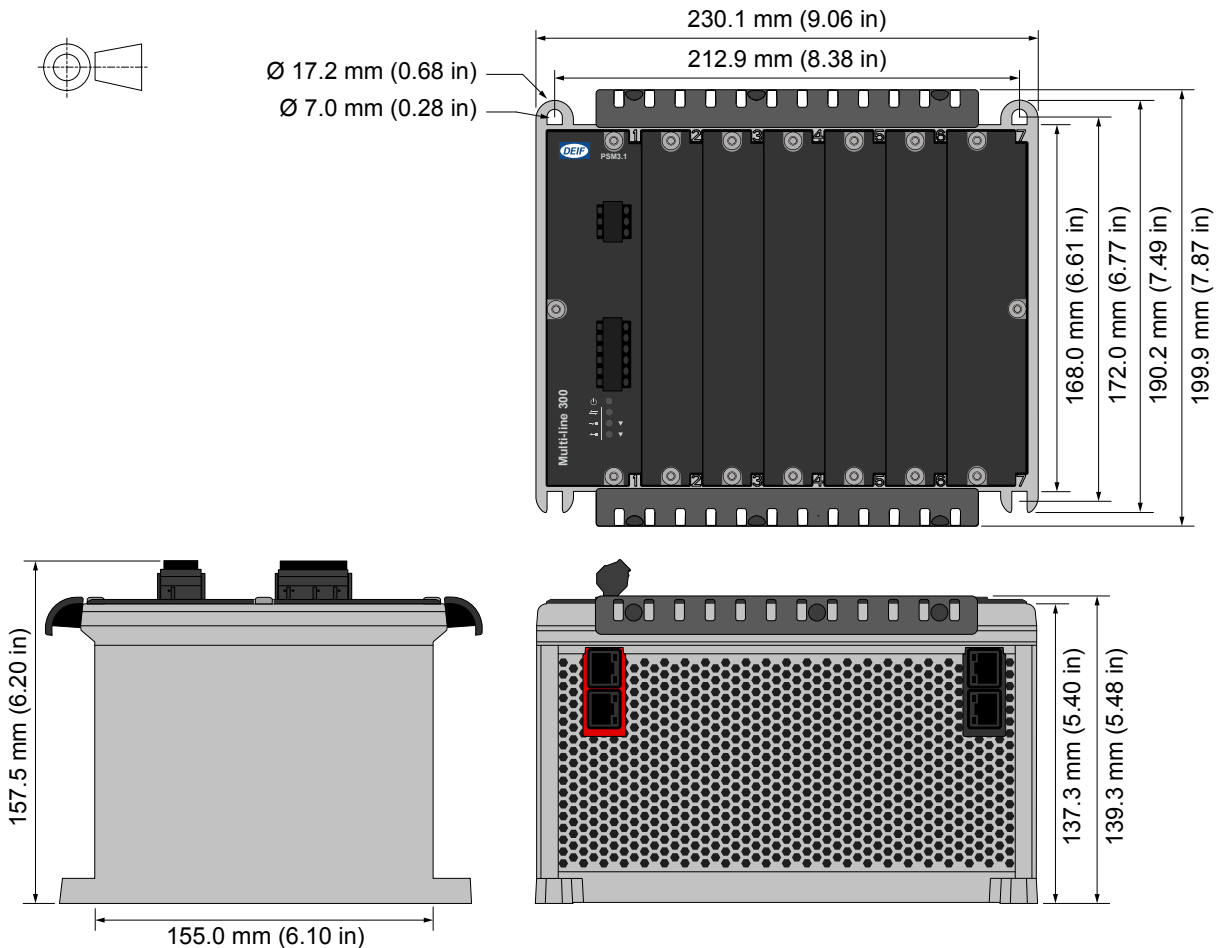

## 3.3 Hardware module specifications







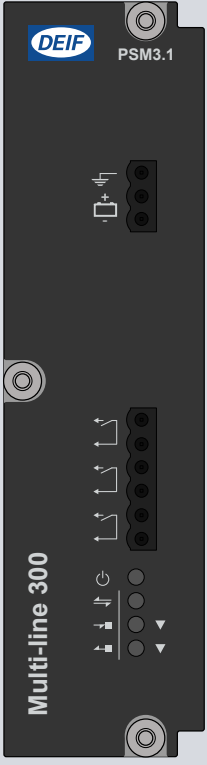

### 3.3.1 Power supply module PSM3.1 (Controller)

The power supply module provides power to all hardware modules in the rack. The rack status and alarms activate the three relay outputs. There are two ports for internal communication (EtherCAT) only with extension racks.



The PSM3.1 must be powered by a power supply with Power Boost function.

The PSM3.1 manages the hardware module self-checks for the rack and includes a power LED. The power supply terminals include circuit protection against load dump transients and JEM177 surge transients (rugged design). These terminals also include battery voltage measurement.

## PSM3.1 terminals

Module	Count	Symbol	Type/Info	Name
 <p>PSM3.1</p> <p>Multi-line 300</p>	1		Ground	Frame ground
	1		12 or 24 V	Power supply
	3		Relay output	1 × Status OK (fixed) 2 × configurable
	1		<ul style="list-style-type: none"> <li>● <b>Off</b> : No power supply</li> <li>☀ <b>Red flash</b> : PSM is starting or module failure</li> <li>● <b>Green</b> : Power supply</li> <li>☀ <b>Green flash</b> : Controller identification</li> </ul>	Power supply indication
	1		<ul style="list-style-type: none"> <li>● <b>Off</b> : No EtherCAT communication</li> <li>● <b>Green</b> : EtherCAT Communication</li> </ul>	EtherCAT communication connections (to connect to extension racks).  LEDs are on the module front, connections are at the module bottom.
	1		EtherCAT communication (RJ45) input <ul style="list-style-type: none"> <li>● <b>Off</b> : No communication</li> <li>● <b>Green</b> : Communication connected</li> <li>☀ <b>Green flash</b> : Active communication</li> </ul>	
	1		EtherCAT communication (RJ45) output <ul style="list-style-type: none"> <li>● <b>Off</b> : No communication</li> <li>● <b>Green</b> : Communication connected</li> <li>☀ <b>Green flash</b> : Active communication</li> </ul>	

## PSM3.1 technical specifications

Category	Specification
<b>Frame ground</b> 	Voltage withstand: ±36 V DC to the power supply positive (terminal 1) and negative (terminal 2)
<b>Controller power supply</b> 	Input voltage: 12 or 24 V DC nominal (8 to 36 V DC continuously) UL/cUL Listed: 10 to 32.5 V DC 0 V DC for 50 ms when coming from at least 8 V DC (cranking dropout) Consumption: Typical 20 W, maximum 35 W Voltage measurement accuracy: 0 to 30 V: ±1 V; 30 to 36 V: +1/-2 V Internal protection: 12 A fuse (not replaceable) (fuse size determined by load dump requirements) Voltage withstand: ±36 V DC Load dump protected by TVS diodes  <b>Start current</b> <ul style="list-style-type: none"> <li>• Power supply current limiter               <ul style="list-style-type: none"> <li>◦ 24 V: 4 A minimum</li> <li>◦ 12 V: 8 A minimum</li> </ul> </li> <li>• Battery: No limit</li> </ul>
<b>Relay outputs</b> 	Relay type: Solid state Electrical rating and UL/cUL Listed: 30 V DC and 1 A, resistive Voltage withstand: ±36 V DC
<b>Terminal connections</b>	<b>Frame ground and power supply:</b> <ul style="list-style-type: none"> <li>• Terminals: Standard 45° plug, 2.5 mm<sup>2</sup></li> <li>• Wiring: 1.5 to 2.5 mm<sup>2</sup> (16 to 12 AWG), multi-stranded</li> </ul> <b>Other connections:</b>

Category	Specification
	<ul style="list-style-type: none"> <li>Terminals: Standard 45° plug, 2.5 mm<sup>2</sup></li> <li>Wiring: 0.5 to 2.5 mm<sup>2</sup> (22 to 12 AWG), multi-stranded</li> </ul>
<b>Communication connections</b>	EtherCAT communication: RJ45. Use an Ethernet cable that meets or exceeds the SF/UTP CAT5e specifications
<b>Torques and terminals</b>	Module faceplate screws: 0.5 N·m (4.4 lb-in) Connection of wiring to terminals: 0.5 N·m (4.4 lb-in) UL/cUL Listed: Wiring must be minimum 90 °C (194 °F) copper conductors only
<b>Galvanic isolation</b>	Between power supply and other I/Os: 600 V, 50 Hz for 60 s Between relay groups and other I/Os: 600 V, 50 Hz for 60 s Between internal communication ports and other I/Os: 600 V, 50 Hz for 60 s
<b>Ingress protection</b>	Unmounted: No protection rating Mounted in rack: IP20 according to IEC/EN 60529
<b>Dimensions</b>	L×H×D: 43.3 × 162 × 150 mm (1.5 × 6.4 × 5.9 in)
<b>Weight</b>	331 g (0.7 lb)







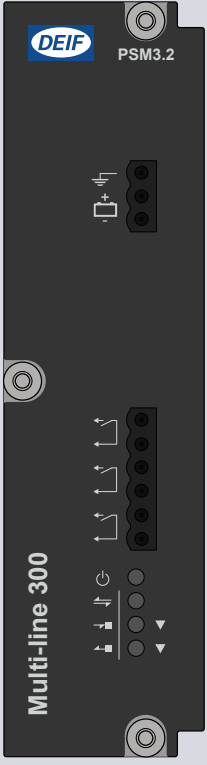

### 3.3.2 Power supply module PSM3.2 (Extension)

The power supply module provides power to all hardware modules in the extension rack. There are two ports for internal communication with the main controller. The internal communication (EtherCAT) connections are only used to communicate with the main controller. The rack status and alarms activate the three relay outputs.



The PSM3.2 must to be powered by a power supply with Power Boost function.

The PSM3.2 manages the hardware module self-checks for the rack and includes a power LED. The power supply terminals include circuit protection against load dump transients and JEM177 surge transients (rugged design). These terminals also include battery voltage measurement.

## PSM3.2 terminals

Module	Count	Symbol	Type/Info	Name
 <p>PSM3.2</p> <p>Multi-line 300</p>	1		Ground	Frame ground
	1		12 or 24 V	Power supply
	3		Relay output	1 × Status OK (fixed) 2 × configurable
	1		<ul style="list-style-type: none"> <li>● <b>Off</b> : No power supply</li> <li>☀ <b>Red flash</b> : PSM is starting or module failure</li> <li>● <b>Green</b> : Power supply</li> <li>☀ <b>Green flash</b> : Rack identification</li> </ul>	Power supply indication
	1		<ul style="list-style-type: none"> <li>● <b>Off</b> : No EtherCAT communication</li> <li>● <b>Green</b> : EtherCAT Communication</li> </ul>	EtherCAT communication connections (to connect to the racks). LEDs are on the module front, connections are at the module bottom.
	1		EtherCAT communication (RJ45) input <ul style="list-style-type: none"> <li>● <b>Off</b> : No communication</li> <li>● <b>Green</b> : Communication connected</li> <li>☀ <b>Green flash</b> : Active communication</li> </ul>	
	1		EtherCAT communication (RJ45) output <ul style="list-style-type: none"> <li>● <b>Off</b> : No communication</li> <li>● <b>Green</b> : Communication connected</li> <li>☀ <b>Green flash</b> : Active communication</li> </ul>	

## PSM3.2 technical specifications

Category	Specification
<b>Frame ground</b> 	Voltage withstand: ±36 V DC to the power supply positive (terminal 1) and negative (terminal 2)
<b>Controller power supply</b> 	Input voltage: 12 or 24 V DC nominal (8 to 36 V DC continuously) UL/cUL Listed: 10 to 32.5 V DC 0 V DC for 50 ms when coming from at least 8 V DC (cranking dropout) Consumption: Typical 20 W, maximum 35 W Voltage measurement accuracy: 0 to 30 V: ±1 V; 30 to 36 V: +1/-2 V Internal protection: 12 A fuse (not replaceable) (fuse size determined by load dump requirements) Voltage withstand: ±36 V DC Load dump protected by TVS diodes  <b>Start current</b> <ul style="list-style-type: none"> <li>• Power supply current limiter               <ul style="list-style-type: none"> <li>◦ 24 V: 4 A minimum</li> <li>◦ 12 V: 8 A minimum</li> </ul> </li> <li>• Battery: No limit</li> </ul>
<b>Relay outputs</b> 	Relay type: Solid state Electrical rating and UL/cUL Listed: 30 V DC and 1 A, resistive Voltage withstand: ±36 V DC
<b>Terminal connections</b>	<b>Frame ground and power supply:</b> <ul style="list-style-type: none"> <li>• Terminals: Standard 45° plug, 2.5 mm<sup>2</sup></li> <li>• Wiring: 1.5 to 2.5 mm<sup>2</sup> (16 to 12 AWG), multi-stranded</li> </ul> <b>Other connections:</b>



Category	Specification
	<ul style="list-style-type: none"> <li>Terminals: Standard 45° plug, 2.5 mm<sup>2</sup></li> <li>Wiring: 0.5 to 2.5 mm<sup>2</sup> (22 to 12 AWG), multi-stranded</li> </ul>
<b>Communication connections</b>	EtherCAT communication: RJ45. Use an Ethernet cable that meets or exceeds the SF/UTP CAT5e specifications
<b>Torques and terminals</b>	Module faceplate screws: 0.5 N·m (4.4 lb-in) Connection of wiring to terminals: 0.5 N·m (4.4 lb-in) UL/cUL Listed: Wiring must be minimum 90 °C (194 °F) copper conductors only
<b>Galvanic isolation</b>	Between power supply and other I/Os: 600 V, 50 Hz for 60 s Between relay groups and other I/Os: 600 V, 50 Hz for 60 s Between internal communication ports and other I/Os: 600 V, 50 Hz for 60 s
<b>Ingress protection</b>	Unmounted: No protection rating Mounted in rack: IP20 according to IEC/EN 60529
<b>Dimensions</b>	L×H×D: 43.3 × 162 × 150 mm (1.5 × 6.4 × 5.9 in)
<b>Weight</b>	331 g (0.7 lb)

### 3.3.3 Alternating current module ACM3.1

The alternating current module ACM3.1 measures the voltage and current on one side of a breaker, and the voltage on the other side. The hardware module responds when the measurements exceed the AC alarm parameters.

ACM3.1 provides robust frequency detection in environments with electrical noise. ACM3.1 allows extended measurement bandwidth up to 40 times the nominal frequency. ACM3.1 includes a configurable 4th current measurement.

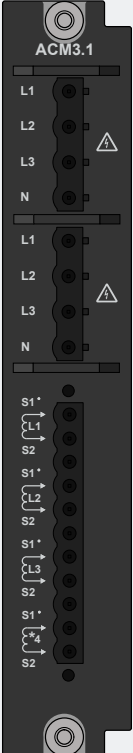
#### ACM3.1 terminals

Module	Count	Symbol	Type	Name
	2 × (L1, L2, L3 and N)	L1/L2/L3/N	Voltage	3-phase voltage measurements
	1 × (L1, L2, L3 and 4th)		Current	3-phase current measurement  4th current measurement

### ACM3.1 technical specifications

Category	Specification
<b>Voltage measurements</b>	Nominal value: 100 to 690 V AC phase-to-phase Measurement range: 2 to 897 V AC phase-to-phase Accuracy: Class 0.2 Phase angle accuracy: 0.1° (within nominal voltage range and nominal frequency range) Altitude derating from 2,000 to 4,000 m (6,562 to 13,123 ft): 100 to 480 V AC phase-to-phase UL/cUL Listed: 100 to 600 V AC phase-to-phase Load on external voltage transformer: Maximum 0.2 VA/phase Voltage withstand: 1.2 × Nominal voltage continuously; 1.3 × Nominal voltage for 10 s
<b>Current measurements</b>	Nominal value: 1 or 5 A AC from current transformer Measurement range: 0.02 to 17.5 A AC from current transformer; Truncation level: 11 mA Accuracy: Class 0.2 Earth current: 18 dB attenuation of third harmonic of the nominal frequency UL/cUL Listed: From listed or R/C (XODW2.8) current transformers 1 or 5 A Load on external current transformer: Maximum 0.3 VA/phase Current withstand: 10 A continuously; 17.5 A for 60 s; 100 A for 10 s; 250 A for 1 s
<b>Frequency measurements</b>	Nominal value: 50 Hz or 60 Hz Measurement range: 35 to 78 Hz Accuracy: Class 0.1 of nominal value (35 to 78 Hz) (-40 to 70 °C) (-40 to 158 °F) Class 0.02 of nominal value (40 to 70 Hz) (15 to 30 °C) (59 to 86 °F)
<b>Power measurements</b>	Accuracy: Class 0.5
<b>Accuracy and temperature</b>	Unless otherwise specified for the above measurements: Nominal range: -40 to 70 °C (-40 to 158 °F) Reference range: 15 to 30 °C (59 to 86 °F) Accuracy: Measurement type specific within reference range Additional 0.2 % error of full scale per 10 °C (18 °F) outside reference range
<b>Torques and terminals</b>	Module faceplate screws: 0.5 N·m (4.4 lb-in) Secure the current measurement terminal block to the module faceplate: 0.25 N·m (2.2 lb-in) Connection of wiring to terminals: 0.5 N·m (4.4 lb-in) UL/cUL Listed: Wiring must be minimum 90 °C (194 °F) copper conductors only
<b>Terminal connections</b>	AC voltage and current terminals: Standard 45° plugs, 2.5 mm <sup>2</sup> Wiring: 2.5 mm <sup>2</sup> (13 AWG), multi-stranded
<b>Galvanic isolation</b>	Between AC voltage and other I/Os: 3310 V, 50 Hz for 60 s Between AC current and other I/Os: 2210 V, 50 Hz for 60 s
<b>Ingress protection</b>	Unmounted: No protection rating Mounted in rack: IP20 according to IEC/EN 60529
<b>Dimensions</b>	L×H×D: 28 × 162 × 150 mm (1.1 × 6.4 × 5.9 in)
<b>Accessories (included)</b>	<ul style="list-style-type: none"> <li>• One roundel with 6 J-shaped voltage encoding pins (for the hardware module)</li> <li>• One roundel with 6 flat voltage encoding pins (for the voltage terminal blocks)</li> </ul>
<b>Weight</b>	232 g (0.5 lb)

### 3.3.4 Differential current module ACM3.2

The differential current module ACM3.2 measures the generator outgoing 3-phase currents (consumer side) and star point 3-phase currents. The ACM3.2 uses the measurements to detect phase-to-phase faults or phase-to-earth faults (star point earthed generator stator only) in the generator stator, and dependent on the mounting of the CT's on the outgoing side, possibly also the cable between the generator and the main switchboard.

The protection consists of:

- A stabilised stage that uses an operating characteristic formed by a fixed and two sloped regions. This current restraint approach is also known as biased differential protection.
- A high set fixed differential stage (non-stabilised).

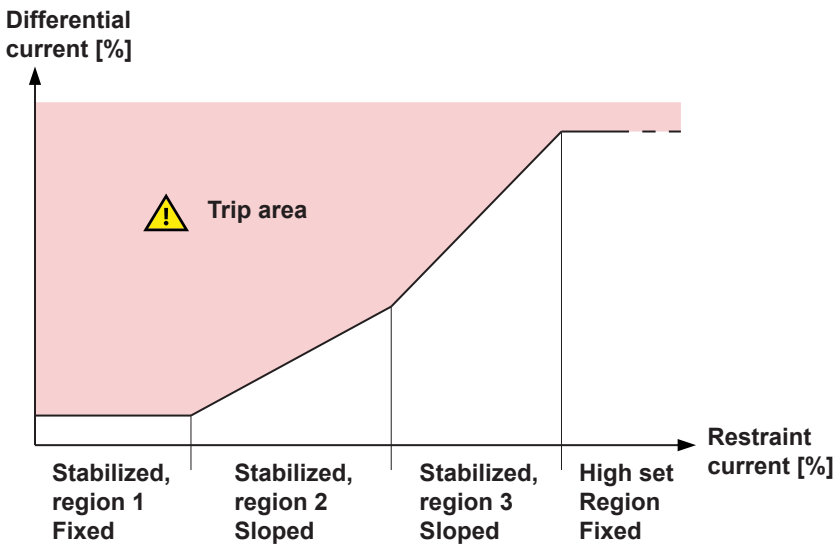

### ACM3.2 terminals

Module	Count	Symbol	Type	Name
	1 × (L1, L2 and L3)		Current	3-phase current measurement - Consumer side
	1 × (L1, L2 and L3)		Current	3-phase current measurement - Neutral side

### ACM3.2 technical specifications

Category	Specification
<b>Nominal, reference and operating values</b>	Current: Nominal value: 1 or 5 A AC from current transformer Frequency: <ul style="list-style-type: none"> <li>Nominal value: 50 or 60 Hz</li> <li>Reference range: 40 to 70 Hz</li> <li>Operating range: 20 to 78 Hz</li> </ul> Temperature: <ul style="list-style-type: none"> <li>Reference range: 15 to 30 °C (59 to 86 °F)</li> <li>Operating range: -40 to 70 °C (-40 to 158 °F)</li> </ul>
<b>Current measurements</b>	Measurement range: 0.025 to 250 A AC. Truncation level: 20 mA

Category	Specification
	Accuracy: <ul style="list-style-type: none"> <li>• 0.025 to 20 A: <math>\pm 1\%</math> or <math>\pm 10</math> mA of measured current (whichever is greater)</li> <li>• 20 to 250 A: <math>\pm 1.5\%</math> of measured current</li> </ul> UL/cUL Listed: From listed or R/C (XODW2.8) current transformers 1 or 5 A Load on external current transformer: $< 4$ m $\Omega$ , including the terminal block Current withstand: <ul style="list-style-type: none"> <li>• 20 A continuously</li> <li>• 100 A for 10 s</li> <li>• 400 A for 1 s</li> <li>• 1250 A for 10 ms (half wave)</li> </ul>
<b>Frequency measurement</b>	Accuracy (within operating range): $> 0.1$ A: $\pm 0.1\%$ of actual frequency
<b>Temperature</b>	Current measurement accuracy temperature coefficient: $\pm 0.25\%$ , or $\pm 2.5$ mA per 10 °C (18 °F) outside reference range (whichever is greater)
<b>Torques and terminals</b>	Module faceplate screws: 0.5 N·m (4.4 lb-in) Secure the current measurement terminal block to the module faceplate: 0.25 N·m (2.2 lb-in) Connection of wiring to terminals: <ul style="list-style-type: none"> <li>• <math>\leq 4</math> mm<sup>2</sup>: 0.5 N·m (4.4 lb-in) to 0.6 N·m (5.3 lb-in)</li> <li>• <math>&gt; 4</math> mm<sup>2</sup>: 0.7 N·m (6.2 lb-in) to 0.8 N·m (7.1 lb-in)</li> </ul> UL/cUL Listed: Wiring must be minimum 90 °C (194 °F) copper conductors only
<b>Terminal connections</b>	AC current terminals: Standard 0° plugs, 6 mm <sup>2</sup> with securing screws Wiring: 2.5 to 6 mm <sup>2</sup> (13 to 10 AWG), multi-stranded
<b>Galvanic isolation</b>	Between AC current and other I/Os: 2210 V, 50 Hz for 60 s
<b>Ingress protection</b>	Unmounted: No protection rating Mounted in rack: IP20 according to IEC/EN 60529
<b>Dimensions</b>	L×H×D: 28 × 162 mm × 152 mm (1.1 × 6.4 × 5.9 in)
<b>Weight</b>	230 g (0.5 lb) (including terminal blocks)
<b>Accessories (included)</b>	One roundel with 6 encoding pins (for the hardware module and terminal block)

### 3.3.5 Engine interface module EIM3.1

The engine interface module has its own power supply and a tacho input to measure speed. It also has four relay outputs, four digital inputs, and three analogue inputs. These I/Os are configurable.

The power supply terminals include circuit protection against load dump transients and JEM177 surge transients (rugged design). These terminals also include battery voltage measurement.

EIM3.1 has its own microprocessor. If the rack power supply fails, or connection to the application is lost, the EIM3.1 can continue to operate independent of the application.



## EIM3.1 terminals

Module	Count	Symbol	Type	Name
	1		Ground	Frame ground
	1		12 or 24 V DC	Power supply
	3		Relay output	Configurable
	1		Relay output (with wire break detection)	Configurable
	4		Digital input	Configurable
	1		MPU input (with wire break detection)*	Magnetic pickup
	1	W	W input (no wire break detection)*	Generator tacho output or NPN/PNP sensor
	3	R <sub>1</sub> →	Analogue current or resistance measurement input (RMI)	Configurable

**NOTE** \* These inputs cannot both be used at the same time.

## EIM3.1 technical specifications

Category	Specification
<b>Frame ground</b>	Voltage withstand: ±36 V DC to the power supply positive (terminal 1) and negative (terminal 2)
<b>Auxiliary power supply</b>	Input voltage: 12 or 24 V DC nominal (8 to 36 V DC continuously) UL/cUL Listed: 10 to 32.5 V DC 0 V DC for 50 ms when coming from at least 8 V DC (cranking dropout) Consumption: Typical 3 W, maximum 5 W Internal protection: by 12 A fuse (not replaceable) (fuse size determined by load dump requirements) Voltage withstand: ±36 V DC Load dump protected by TVS diodes  <b>Start current</b> <ul style="list-style-type: none"> <li>• Power supply current limiter               <ul style="list-style-type: none"> <li>◦ 24 V: 0.6 A minimum</li> <li>◦ 12 V: 1.2 A minimum</li> </ul> </li> <li>• Battery: No limit</li> </ul>
<b>Relay outputs</b>	Relay type: Electromechanical Electrical rating and UL/cUL Listed: 30 V DC and 6 A, resistive Voltage withstand: ±36 V DC
<b>Relay output with wire break detection</b>	Relay type: Electromechanical Electrical rating and UL/cUL Listed: 30 V DC and 6 A, resistive Includes wire break detection Voltage withstand: ±36 V DC
<b>Magnetic pickup</b>	Voltage: 3 to 70 V AC peak Frequency: 2 to 20,000 Hz

Category	Specification
	<p>Accuracy: 2 to 99 Hz: 0.5 Hz; 100 to 20,000 Hz: <math>\pm 0.5</math> % of measurement  Cable supervision: Resistance maximum 100 k<math>\Omega</math>  Includes wire break detection  Voltage withstand: 70 V AC</p>
<b>Generator tachometer (W)</b>	<p>Voltage: 8 to 36 V DC  Frequency: 2 to 20,000 Hz  Accuracy: 2 to 99 Hz: 0.5 Hz; 100 to 20,000 Hz: <math>\pm 0.5</math> % of measurement  No wire break detection  Voltage withstand: <math>\pm 36</math> V DC</p>
<b>NPN/PNP</b>	<p>Voltage: 8 to 36 V DC  Frequency: 2 to 20,000 Hz  Accuracy: 2 to 99 Hz: 0.5 Hz; 100 to 20,000 Hz: <math>\pm 0.5</math> % of measurement  No wire break detection  Voltage withstand: <math>\pm 36</math> V DC</p>
<b>Digital inputs</b> 	<p>Bipolar inputs</p> <ul style="list-style-type: none"> <li>ON: -36 to -8 V DC, and 8 to 36 V DC</li> <li>OFF: -2 to 2 V DC</li> </ul> <p>Minimum pulse length: 50 ms  Impedance: 4.7 k<math>\Omega</math>  Voltage withstand: <math>\pm 36</math> V DC</p>
<b>Analogue multi-functional inputs</b> 	<p><b>Current input</b></p> <ul style="list-style-type: none"> <li>From active transmitter: 0 to 20 mA, 4 to 20 mA, or any custom range between 0 and 25 mA</li> <li>Accuracy: 1 % of selected range</li> </ul> <p><b>Pt100/1000</b></p> <ul style="list-style-type: none"> <li>-40 to 250 °C (-40 to 482 °F)</li> <li>Accuracy: 1 % of full scale (to IEC/EN60751)</li> <li>Maximum sensor self-heating: 0.5 °C/mW (1 °F/mW)</li> </ul> <p><b>Resistance measurement</b></p> <ul style="list-style-type: none"> <li>Any custom range between 0 and 2.5 k<math>\Omega</math></li> <li>Accuracy: 1 % over ranges: 0 to 200 <math>\Omega</math>, 0 to 300 <math>\Omega</math>, 0 to 500 <math>\Omega</math>, 0 to 1000 <math>\Omega</math>, and 0 to 2500 <math>\Omega</math></li> </ul> <p><b>Digital input</b></p> <ul style="list-style-type: none"> <li>Dry contact with cable supervision</li> <li>Maximum circuit resistance: 330 <math>\Omega</math></li> <li>Minimum current rating for the connected relay: 2.5 mA</li> </ul> <p>Voltage withstand: <math>\pm 36</math> V DC  All analogue multi-functional inputs for EIM3.1 have a common ground</p>
<b>Terminal connections</b>	<p><b>Frame ground and power supply</b></p> <ul style="list-style-type: none"> <li>Terminals: Standard 45° plug, 2.5 mm<sup>2</sup></li> <li>Wiring: 1.5 to 2.5 mm<sup>2</sup> (16 to 12 AWG), multi-stranded</li> </ul> <p><b>Other connections</b></p> <ul style="list-style-type: none"> <li>Terminals: Standard 45° plug, 2.5 mm<sup>2</sup></li> <li>Wiring: 0.5 to 2.5 mm<sup>2</sup> (22 to 12 AWG), multi-stranded</li> </ul>
<b>Torques and terminals</b>	<p>Module faceplate screws: 0.5 N·m (4.4 lb-in)  Connection of wiring to terminals: 0.5 N·m (4.4 lb-in)  UL/cUL Listed: Wiring must be minimum 90 °C (194 °F) copper conductors only</p>
<b>Galvanic isolation</b>	<p>Between relay groups and other I/Os: 600 V, 50 Hz for 60 s  Between digital input groups and other I/Os: 600 V, 50 Hz for 60 s  Between MPU and W inputs and other I/Os: 600 V, 50 Hz for 60 s  Between analogue inputs and other I/Os: 600 V, 50 Hz for 60 s</p>







Category	Specification
Ingress protection	Unmounted: No protection rating Mounted in rack: IP20 according to IEC/EN 60529
Dimensions	L×H×D: 28 × 162 × 150 mm (1.1 × 6.4 × 5.9 in)
Weight	250 g (0.5 lb)

### 3.3.6 Governor and AVR module GAM3.1

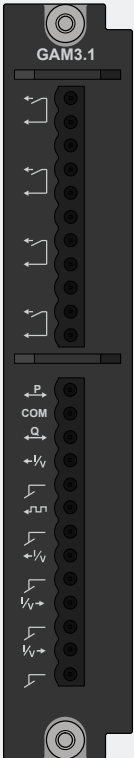



This governor and AVR module has four relay outputs, two analogue outputs and a pulse width modulation output, and two analogue inputs. These I/Os are configurable.

GAM3.1 also has terminals for analogue load sharing (future use).

#### GAM3.1 terminals

Module	Count	Symbol	Type	Name
	4		Relay output	Configurable
	1		Load sharing	Active power (P) (kW) load sharing (future use)
	1		Load sharing	Reactive power (Q) (kvar) sharing (future use)
	2		Analogue current or voltage output	GOV/AVR/configurable
	1		Pulse width modulation (PWM) output	PWM output (with PWM ground)
	2		Analogue current or voltage input	Configurable

#### GAM3.1 technical specifications

Category	Specification
<b>Relay outputs</b> 	Relay type: Electromechanical Electrical rating and UL/cUL Listed: 250 V AC or 30 V DC, and 6 A, resistive; B300, pilot duty (B300 is a power limit specification for inductive loads) Altitude derating from 2,000 to 4,000 m (6,562 to 13,123 ft): Maximum 150 V AC phase-to-phase Voltage withstand: 250 V AC
<b>Load sharing (future use)</b>  	Voltage input/output: -5 to 5 V DC Impedance: 23.5 kΩ Accuracy: 1 % of full scale, for both inputs and outputs Voltage withstand: ±36 V DC
<b>Analogue multi-functional outputs</b> 	<b>Current output</b> <ul style="list-style-type: none"> <li>-20 to 20 mA, or 0 to 20 mA, or 4 to 20 mA, or any custom range between -25 and 25 mA</li> <li>Accuracy: 1 % of the selected range (minimum range: 5 mA)</li> </ul>







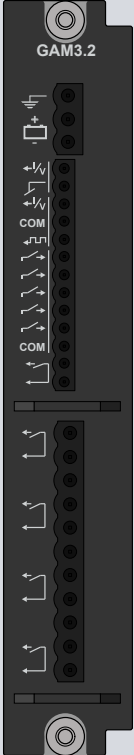

Category	Specification
	<ul style="list-style-type: none"> <li>16-bit resolution over the range -25 to 25 mA</li> <li>Active output (internal supply)</li> <li>Maximum load: 400 Ω</li> </ul> <b>Voltage output (DC)</b> <ul style="list-style-type: none"> <li>-10 to 10 V, 0 to 10 V, 0 to 5 V, -5 to 5 V, 0 to 3 V, -3 to 3 V, or 0 to 1 V, or any custom range between -10 and 10 V</li> <li>Accuracy: 1 % of the selected range (minimum range: 1 V)</li> <li>16-bit resolution over the range -10 to 10 V</li> <li>Minimum load: 600 Ω. Voltage output internal resistance: &lt; 1 Ω</li> </ul> Voltage withstand: ±36 V DC Controller power off: Internal resistance > 10 MΩ
<b>Pulse width modulation (PWM) output</b> ←□□	Frequency: 500 Hz ±50 Hz Resolution: 43,200 levels Voltage: <ul style="list-style-type: none"> <li>Low level: &lt; 0.5 V</li> <li>High level: &gt; 5.5 V</li> <li>Maximum: 6.85 V</li> </ul> Output impedance: 100 Ω Nominal temperature range: -40 to 70 °C (-40 to 158 °F) Reference temperature range: 15 to 30 °C (59 to 86 °F) Duty cycle accuracy (5 to 95 %): 0.25 % within reference temperature range 0.2 % of full scale additional error per 10 °C (18 °F) outside the reference range Example: At 70 °C (158 °F) the accuracy of the PWM output is 0.25 % + 4 × 0.2 % = 1.05 % Voltage withstand: ±30 V DC
<b>Analogue multi-functional inputs</b> I/V→	<b>Current inputs</b> <ul style="list-style-type: none"> <li>From active transmitter: 0 to 20 mA, 4 to 20 mA, or any custom range between 0 and 24 mA</li> <li>Accuracy: 1 % of selected range</li> </ul> <b>Voltage inputs (DC)</b> <ul style="list-style-type: none"> <li>-10 to 10 V, 0 to 10 V, or any custom range between -10 and 10 V</li> <li>Accuracy: 1 % of selected range</li> </ul> Voltage withstand: ±36 V DC
<b>Terminal connections</b>	Terminals: Standard 45° plug, 2.5 mm <sup>2</sup> Wiring: 0.5 to 2.5 mm <sup>2</sup> (22 to 12 AWG), multi-stranded
<b>Torques and terminals</b>	Module faceplate screws: 0.5 N·m (4.4 lb-in) Connection of wiring to terminals: 0.5 N·m (4.4 lb-in) UL/cUL Listed: Wiring must be minimum 90 °C (194 °F) copper conductors only
<b>Galvanic isolation</b>	Between individual relays and other I/Os: 2210 V, 50 Hz for 60 s Between load sharing and other I/Os: 600 V, 50 Hz for 60 s Between terminals 12 to 15 (analogue output 1, PWM output), and other I/Os: 600 V, 50 Hz for 60 s <ul style="list-style-type: none"> <li>Analogue output 1 and the PWM output are galvanically connected</li> </ul> Between terminals 16, 17 (analogue output 2) and other I/Os: 600 V, 50 Hz for 60 s Between terminals 18 to 21 (analogue inputs) and other I/Os: 600 V, 50 Hz for 60 s <ul style="list-style-type: none"> <li>Analogue inputs 1 and 2 are galvanically connected</li> </ul>
<b>Ingress protection</b>	Unmounted: No protection rating Mounted in rack: IP20 according to IEC/EN 60529
<b>Dimensions</b>	L×H×D: 28 × 162 × 150 mm (1.1 × 6.4 × 5.9 in)
<b>Weight</b>	224 g (0.5 lb)

### 3.3.7 Governor and AVR module GAM3.2



This governor and AVR module has its own power supply, two analogue outputs and a pulse width modulation output, five digital inputs, a status relay output, and four relay outputs. Apart from the status relay, all these I/Os are configurable.

GAM3.2 has its own microprocessor. If the rack power supply fails, GAM3.2 can continue to be used for manual operation if it has its own, independent power supply. The power supply terminals include circuit protection against load dump transients and JEM177 surge transients (rugged design). These terminals also include battery voltage measurement.

#### GAM3.2 terminals

Module	Count	Symbol	Type	Name
	1		Ground	Frame ground
	1		12 or 24 V	Power supply
	2		Analogue current or voltage output	GOV/AVR/configurable
	1		Pulse width modulation (PWM) output	PWM output
	5		Digital input	Configurable
	1		Relay output	GAM3.2 status
	4		Relay output	Configurable

#### GAM3.2 technical specifications

Category	Specification
<b>Auxiliary power supply</b> 	Input voltage: 12 or 24 V DC nominal (8 to 36 V DC continuously) UL/cUL Listed: 10 to 32.5 V DC 0 V DC for 50 ms when coming from at least 8 V DC (cranking dropout) Consumption: Typical 3 W, maximum 5 W Voltage measurement accuracy: $\pm 0.1$ V (measurement range 8 to 36 V DC) Internally protection: 12 A fuse (not replaceable) (fuse size determined by load dump requirements) Voltage withstand: $\pm 36$ V DC Load dump protected by TVS diodes  <b>Start current</b> <ul style="list-style-type: none"> <li>• Power supply current limiter               <ul style="list-style-type: none"> <li>◦ 24 V: 0.6 A minimum</li> <li>◦ 12 V: 1.2 A minimum</li> </ul> </li> <li>• Battery: No limit</li> </ul>
<b>Analogue multi-functional outputs</b> 	<b>Current output</b> <ul style="list-style-type: none"> <li>• Any custom range between -25 and 25 mA</li> <li>• Accuracy: 1 % of the selected range (minimum range: 5 mA)</li> </ul>



Category	Specification
	<ul style="list-style-type: none"> <li>16-bit resolution</li> <li>Active output (internal supply)</li> <li>Maximum load: 400 Ω</li> </ul> <b>Voltage output (DC)</b> <ul style="list-style-type: none"> <li>Any custom range between -10 and 10 V</li> <li>Accuracy: 1 % of the selected range (minimum range: 1 V)</li> <li>16-bit resolution</li> <li>Minimum load: 600 Ω. Voltage output internal resistance: &lt; 1 Ω.</li> </ul> Voltage withstand: ±36 V DC Controller power off: Internal resistance > 10 MΩ
<b>Pulse width modulation (PWM) output</b> ↔	Frequency: 500 Hz ±50 Hz Resolution: 43,200 levels Voltage: <ul style="list-style-type: none"> <li>Low level: &lt; 0.5 V</li> <li>High level: &gt; 5.5 V</li> <li>Maximum: 6.85 V</li> </ul> Output impedance: 100 Ω Nominal temperature range: -40 to 70 °C (-40 to 158 °F) Reference temperature range: 15 to 30 °C (59 to 86 °F) Duty cycle accuracy (5 to 95 %): 0.25 % within reference temperature range 0.2 % of full scale additional error per 10 °C (18 °F) outside the reference range Example: At 70 °C (158 °F) the accuracy of the PWM output is 0.25 % + 4 × 0.2 % = 1.05 % Voltage withstand: ±30 V DC
<b>Digital inputs</b> ↔	Bipolar inputs <ul style="list-style-type: none"> <li>ON: -36 to -8 V DC, and 8 to 36 V DC</li> <li>OFF: -2 to 2 V DC</li> </ul> Minimum pulse length: 50 ms Impedance: 4.7 kΩ Voltage withstand: ±36 V DC
<b>Relay output</b> (GAM3.2 status) ↔	Relay type: Solid state Electrical rating and UL/cUL Listed: 30 V DC and 1 A, resistive Voltage withstand: ±36 V DC
<b>Relay outputs</b> ↔	Relay type: Electromechanical Electrical rating and UL/cUL Listed: 250 V AC or 30 V DC, and 6 A, resistive; B300, pilot duty (B300 is a power limit specification for inductive loads) Altitude derating from 2,000 to 4,000 m (6,562 to 13,123 ft): Maximum 150 V AC phase-to-phase Voltage withstand: 250 V AC
<b>Terminal connections</b>	<b>Frame ground and power supply</b> <ul style="list-style-type: none"> <li>Terminals: Standard 45° plug, 2.5 mm<sup>2</sup></li> <li>Wiring: 1.5 to 2.5 mm<sup>2</sup> (16 to 12 AWG), multi-stranded</li> </ul> <b>Analogue inputs, PWM, digital inputs and the status relay</b> <ul style="list-style-type: none"> <li>Terminals: Standard 45° plug, 1.5 mm<sup>2</sup></li> <li>Wiring: 0.5 to 1.5 mm<sup>2</sup> (28 to 16 AWG), multi-stranded</li> </ul> <b>Relay outputs</b> <ul style="list-style-type: none"> <li>Terminals: Standard 45° plug, 2.5 mm<sup>2</sup></li> <li>Wiring: 0.5 to 2.5 mm<sup>2</sup> (22 to 12 AWG), multi-stranded</li> </ul>
<b>Torques and terminals</b>	Module faceplate screws: 0.5 N·m (4.4 lb-in) Connection of wiring to frame ground and power supply terminals: 0.5 N·m (4.4 lb-in) Connection of wiring to analogue inputs, PWM, digital inputs, and the status relay terminals: 0.25 N·m (2.2 lb-in)

Category	Specification
	Connection of wiring to relay output terminals: 0.5 N·m (4.4 lb-in) UL/cUL Listed: Wiring must be minimum 90 °C (194 °F) copper conductors only
<b>Galvanic isolation</b>	Between power supply and other I/Os: 600 V, 50 Hz for 60 s Between analogue inputs, PWM, digital inputs, and the status relay, and other I/Os: 600 V, 50 Hz for 60 s The analogue output on terminals 5 and 6 is galvanically connected to the PWM output (terminals 6 and 7) Between relay groups and other I/Os: 2210 V, 50 Hz for 60 s
<b>Ingress protection</b>	Unmounted: No protection rating Mounted in rack: IP20 according to IEC/EN 60529
<b>Dimensions</b>	L×H×D: 28 × 162 × 150 mm (1.1 × 6.4 × 5.9 in)
<b>Weight</b>	246 g (0.5 lb)

### 3.3.8 Input/output module IOM3.1

The input output module has 4 changeover relay outputs, and 10 digital inputs. These I/Os are all configurable.

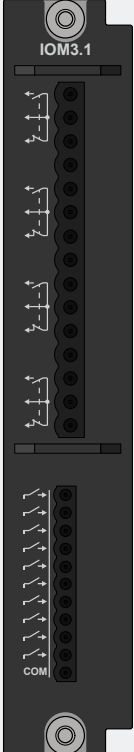
#### IOM3.1 terminals

Module	Count	Symbol	Type	Name
	4		Relay output	Configurable
	10		Digital input	Configurable

#### IOM3.1 technical specifications

Category	Specification
<b>Relay outputs</b> 	Relay type: Electromechanical Electrical rating and UL/cUL Listed: 250 V AC or 30 V DC, and 6 A, resistive; B300, pilot duty (B300 is a power limit specification for inductive loads) Altitude derating from 3,000 to 4,000 m (9,842 to 13,123 ft): Maximum 150 V AC phase-to-phase Voltage withstand: 250 V AC
<b>Digital inputs</b>	Bipolar inputs







Category	Specification
	<ul style="list-style-type: none"> <li>ON: -36 to -8 V DC, and 8 to 36 V DC</li> <li>OFF: -2 to 2 V DC</li> </ul> Minimum pulse length: 50 ms Impedance: 4.7 kΩ Voltage withstand: ±36 V DC
<b>Terminal connections</b>	<b>Relay outputs:</b> Terminals: Standard 45° plug, 2.5 mm <sup>2</sup> Wiring: 0.5 to 2.5 mm <sup>2</sup> (22 to 12 AWG), multi-stranded <b>Digital inputs:</b> Terminals: Standard 45° plug, 1.5 mm <sup>2</sup> Wiring: 0.1 to 1.5 mm <sup>2</sup> (28 to 16 AWG), multi-stranded
<b>Torques and terminals</b>	Module faceplate screws: 0.5 N·m (4.4 lb-in) Connection of wiring to relay output terminals: 0.5 N·m (4.4 lb-in) Connection of wiring to digital input terminals: 0.25 N·m (2.2 lb-in) UL/cUL Listed: Wiring must be minimum 90 °C (194 °F) copper conductors only
<b>Galvanic isolation</b>	Between relay groups and other I/Os: 2210 V, 50 Hz for 60 s Between digital input groups and other I/Os: 600 V, 50 Hz for 60 s
<b>Ingress protection</b>	Unmounted: No protection rating Mounted in rack: IP20 according to IEC/EN 60529
<b>Dimensions</b>	L×H×D: 28 × 162 × 150 mm (1.1 × 6.4 × 5.9 in)
<b>Weight</b>	196 g (0.4 lb)

### 3.3.9 Input/output module IOM3.2

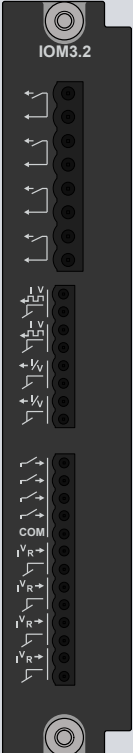



The input output module has 4 relay outputs, 4 analogue multifunctional outputs (including 2 pulse width modulation PWM outputs), 4 digital inputs, and 4 analogue multifunctional inputs. These I/Os are all configurable.

Internal cold junction compensation is not available on IOM3.2

#### IOM3.2 terminals

Module	Count	Symbol	Type	Name
	4		Relay output	Configurable
	2		Analogue multifunctional output (mA, V DC, PWM)	Configurable
	2		Analogue multifunctional output (mA, V DC)	Configurable
	4		Digital input	Configurable
	4		Analogue multifunctional input (mA, V DC, RMI)	Configurable

## IOM3.2 technical specifications

Category	Specification
<b>Relay outputs</b> 	Relay type: Solidstate relay Electrical rating and UL/cUL Listed: 30 V DC, and 6 A, resistive; B300, pilot duty (B300 is a power limit specification for inductive loads) Voltage withstand: $\pm 36$ V DC
<b>Analogue multifunctional outputs</b> 	<b>Current output:</b> <ul style="list-style-type: none"> <li>Range: Any custom range between -25 to 25 mA DC</li> <li>Accuracy: 1 % of range</li> <li>Resolution: 16 bits (<math>&lt; 2</math> uA / bit)</li> <li>Type: Active output (internal supply)</li> <li>Load: Maximum <math>\pm 25</math> mA <math>\rightarrow</math> 400 <math>\Omega</math></li> </ul> <b>Voltage output:</b> <ul style="list-style-type: none"> <li>Range: Any custom range between -10 to 10 V DC</li> <li>Accuracy: 1 % of range</li> <li>Resolution: 16 bits (<math>&lt; 0,7</math> mV / bit)</li> <li>Load: Minimum <math>\pm 10</math>V <math>\rightarrow</math> 600 <math>\Omega</math></li> <li>Internal resistance, power ON: <math>&lt; 1</math> <math>\Omega</math></li> <li>Internal resistance, power OFF: <math>&gt; 10</math> M<math>\Omega</math></li> </ul> <b>General information for all outputs:</b> <ul style="list-style-type: none"> <li>Refresh rate (max): 50ms (input to output)</li> <li>Voltage withstand: <math>\pm 36</math> V DC</li> </ul>
<b>Analogue multifunctional PWM outputs</b> 	<b>PWM output:</b> <ul style="list-style-type: none"> <li>Frequency range: 1 to 2500 Hz <math>\pm 5</math> Hz</li> <li>Duty cycle accuracy (5 to 95 %): 0.5 % within reference temperature range</li> <li>Resolution: 12 bits (4096 steps)</li> <li>Voltage: Low level: <math>&lt; 0.5</math> V. High level: <math>&gt;</math> adjustable 1 to 10 V. Maximum: 10.2 V</li> <li>Output impedance: 25 <math>\Omega</math></li> </ul> <b>General information for all outputs:</b> <ul style="list-style-type: none"> <li>Refresh rate (max): 50 ms (input to output)</li> <li>Voltage withstand: <math>\pm 36</math> V DC</li> </ul>
<b>Digital inputs</b> 	<b>Negative or positive trigger inputs:</b> <ul style="list-style-type: none"> <li>ON: -36 to -8 V DC, and 8 to 36 V DC</li> <li>OFF: -2 to 2 V DC</li> </ul> Minimum pulse length: 50 ms Impedance: 3.9 k $\Omega$ Voltage withstand: $\pm 36$ V DC
<b>Analogue multifunctional inputs</b> 	<b>Digital inputs with wire break detection:</b> <ul style="list-style-type: none"> <li>Dry contact inputs, 3 V DC internal supply</li> <li>Wire-break detection with maximum resistance for ON detection: 100 <math>\Omega</math> to 400 <math>\Omega</math></li> </ul> <b>Current inputs:</b> <ul style="list-style-type: none"> <li>From active transmitter: 0 to 20 mA, or 4 to 20 mA</li> <li>Accuracy: <math>\pm 10</math> uA <math>\pm 0.25</math> % of actual reading</li> </ul> <b>Voltage inputs (DC):</b> <ul style="list-style-type: none"> <li>Range: <math>\pm 10</math> V DC / 0 to 10 V DC</li> <li>Accuracy: <math>\pm 10</math> mV <math>\pm 0.25</math> % of actual reading</li> </ul> <b>Resistance measurement inputs, 2 wire (RMI):</b> <ul style="list-style-type: none"> <li>Resistance measurement: 0 to 4.5 k<math>\Omega</math></li> <li>Accuracy: <math>\pm 1</math> <math>\Omega</math> <math>\pm 0.25</math> % of actual reading</li> </ul>

Category	Specification
	<p><b>Resistance measurement inputs, 1 wire (RMI):</b></p> <ul style="list-style-type: none"> <li>Resistance measurement: 0 to 4.5 k<math>\Omega</math></li> <li>Accuracy: <math>\pm 2 \Omega \pm 0.25 \%</math> of actual reading</li> </ul> <p><b>Pt100:</b></p> <ul style="list-style-type: none"> <li>Range: -200 to 850 <math>^{\circ}\text{C}</math></li> <li>Accuracy: <math>\pm 1 \text{ }^{\circ}\text{C} \pm 0.25 \%</math> of actual reading</li> </ul> <p><b>Pt1000:</b></p> <ul style="list-style-type: none"> <li>Range: -200 to 850 <math>^{\circ}\text{C}</math></li> <li>Accuracy: <math>\pm 0.5 \text{ }^{\circ}\text{C} \pm 0.25 \%</math> of actual reading</li> </ul> <p><b>Thermocouple type, range and accuracy:</b></p> <ul style="list-style-type: none"> <li>E: -200 to 1000 <math>^{\circ}\text{C}</math> ( <math>\pm 2 \text{ }^{\circ}\text{C} \pm 0.25 \%</math> of actual reading)</li> <li>J: -210 to 1200 <math>^{\circ}\text{C}</math> ( <math>\pm 2 \text{ }^{\circ}\text{C} \pm 0.25 \%</math> of actual reading)</li> <li>K: -200 to 1372 <math>^{\circ}\text{C}</math> ( <math>\pm 2 \text{ }^{\circ}\text{C} \pm 0.25 \%</math> of actual reading)</li> <li>N: -200 to 1300 <math>^{\circ}\text{C}</math> ( <math>\pm 2 \text{ }^{\circ}\text{C} \pm 0.25 \%</math> of actual reading)</li> <li>R: -50 to 1768 <math>^{\circ}\text{C}</math> ( <math>\pm 2 \text{ }^{\circ}\text{C} \pm 0.25 \%</math> of actual reading)</li> <li>S: -50 to 1768 <math>^{\circ}\text{C}</math> ( <math>\pm 2 \text{ }^{\circ}\text{C} \pm 0.25 \%</math> of actual reading)</li> <li>T: -200 to 400 <math>^{\circ}\text{C}</math> ( <math>\pm 2 \text{ }^{\circ}\text{C} \pm 0.25 \%</math> of actual reading)</li> </ul> <p><b>Note:</b> Twisted pair and shielded cable is recommended to achieve specification and optimisation of noise immunity.</p> <p><b>General information for all outputs:</b></p> <ul style="list-style-type: none"> <li>Refresh rate (max): 50 ms (input to output)</li> <li>Voltage withstand: <math>\pm 36 \text{ V DC}</math></li> <li>All analogue multi-functional inputs have a common ground</li> </ul>
<b>Terminal connections</b>	<p><b>Relay outputs:</b> Terminals: Standard 45<math>^{\circ}</math> plug, 2.5 mm<sup>2</sup> Wiring: 0.5 to 2.5 mm<sup>2</sup> (22 to 14 AWG), multi-stranded</p> <p><b>Other inputs:</b> Terminals: Standard 45<math>^{\circ}</math> plug, 1.5 mm<sup>2</sup> Wiring: 0.1 to 1.5 mm<sup>2</sup> (28 to 16 AWG), multi-stranded</p>
<b>Torques and terminals</b>	<p>Module faceplate screws: 0.5 N·m (4.4 lb-in) Connection of wiring to relay output terminals: 0.5 N·m (4.4 lb-in) Connection of wiring to digital input terminals: 0.25 N·m (2.2 lb-in) UL/cUL Listed: Wiring must be minimum 90 <math>^{\circ}\text{C}</math> (194 <math>^{\circ}\text{F}</math>) copper conductors only</p>
<b>Galvanic isolation</b>	<p>Between relay groups and other I/Os: 2210 V, 50 Hz for 60 s Between other input groups and other I/Os: 600 V, 50 Hz for 60 s</p>
<b>Ingress protection</b>	<p>Unmounted: No protection rating Mounted in rack: IP20 according to IEC/EN 60529</p>
<b>Dimensions</b>	L×H×D: 28 × 162 × 150 mm (1.1 × 6.4 × 5.9 in)
<b>Weight</b>	188 g (0.4 lb)

### 3.3.10 Input/output module IOM3.3

The input output module has 10 analogue multifunctional inputs. These I/Os are all configurable.

### IOM3.3 terminals

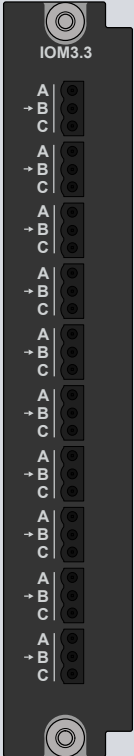
Module	Count	Symbol	Type	Name
	10	<b>A</b> <b>→ B</b> <b>C</b>	Analogue multifunctional inputs (mA, V DC, RMI)	Configurable

### IOM3.3 technical specifications



Category	Specification
<b>Analogue multifunctional inputs</b> <b>A</b> <b>→ B</b> <b>C</b>	<p><b>Digital inputs with wire break detection:</b></p> <ul style="list-style-type: none"> <li>• Dry contact inputs, 3 V DC internal supply</li> <li>• Wire-break detection with maximum resistance for ON detection: 100 Ω to 400 Ω</li> </ul> <p><b>Current inputs:</b></p> <ul style="list-style-type: none"> <li>• From active transmitter: 0 to 20 mA, or 4 to 20 mA</li> <li>• Accuracy: ±10 uA ±0.25 % of actual reading</li> </ul> <p><b>Voltage inputs (DC):</b></p> <ul style="list-style-type: none"> <li>• Range: ±10 V DC / 0 to 10 V DC</li> <li>• Accuracy: ±10 mA ±0.25 % of actual reading</li> </ul> <p><b>Resistance measurement inputs, 2 or 3 wire (RMI):</b></p> <ul style="list-style-type: none"> <li>• Resistance measurement: 0 to 4.5 kΩ</li> <li>• Accuracy: ±1 Ω ±0.25 % of actual reading</li> </ul> <p><b>Resistance measurement inputs, 1 wire (RMI):</b></p> <ul style="list-style-type: none"> <li>• Resistance measurement: 0 to 4.5 kΩ</li> <li>• Accuracy: ±2 Ω ±0.25 % of actual reading</li> </ul> <p><b>Pt100:</b></p> <ul style="list-style-type: none"> <li>• Range: -200 to 850 °C</li> <li>• Accuracy: ±1 °C ±0.25 % of actual reading</li> </ul> <p><b>Pt1000:</b></p> <ul style="list-style-type: none"> <li>• Range: -200 to 850 °C</li> <li>• Accuracy: ±0.5 °C ±0.25 % of actual reading</li> </ul> <p><b>Thermocouple type, range and accuracy:</b></p> <ul style="list-style-type: none"> <li>• E: -200 to 1000 °C ( ±2 °C ±0.25 % of actual reading)</li> <li>• J: -210 to 1200 °C ( ±2 °C ±0.25 % of actual reading)</li> </ul>

Category	Specification
	<ul style="list-style-type: none"> <li>• K: -200 to 1372 °C ( ±2 °C ±0.25 % of actual reading)</li> <li>• N: -200 to 1300 °C ( ±2 °C ±0.25 % of actual reading)</li> <li>• R: -50 to 1768 °C ( ±2 °C ±0.25 % of actual reading)</li> <li>• S: -50 to 1768 °C ( ±2 °C ±0.25 % of actual reading)</li> <li>• T: -200 to 400 °C ( ±2 °C ±0.25 % of actual reading)</li> </ul> <p><b>Note:</b> Twisted pair and shielded cable is recommended to achieve specification and optimisation of noise immunity.</p> <p><b>General information for all inputs:</b></p> <ul style="list-style-type: none"> <li>• Voltage withstand: ±36 V DC</li> </ul>
<b>Internal cold junction compensation (CJC)</b>	<p><b>Internal temperature sensor:</b></p> <ul style="list-style-type: none"> <li>• Range: 0 to 70 °C <ul style="list-style-type: none"> <li>◦ Accuracy: ±1.0 °C</li> </ul> </li> <li>• Range: -40 to 0 °C <ul style="list-style-type: none"> <li>◦ Accuracy: ±2.0 °C</li> </ul> </li> </ul> <p><b>Mathematical compensation:</b></p> <ul style="list-style-type: none"> <li>• If non channels are configured as 4-20 mA <ul style="list-style-type: none"> <li>◦ Accuracy: ±1.0 °C</li> </ul> </li> <li>• If any channels are configured as 4-20 mA <ul style="list-style-type: none"> <li>◦ Accuracy: ±1.5 °C</li> </ul> </li> </ul> <p>If it is needed to have 4-20 mA channels on the same card, it is recommended to use the top channels for 4-20 mA and the lower channels for TC's</p> <p><b>Internal cold junction accuracy:</b></p> <ul style="list-style-type: none"> <li>• Heat dissipated by nearby heat sources can cause errors in thermocouple measurements by heating the IOM3.3 terminals to a different temperature than the cold-junction compensation sensor. Thermal gradient across the terminals can cause the terminals of different IOM3.3 channels to be at different temperatures, which creates accuracy errors and affects the relative accuracy between channels.</li> <li>• The temperature measurement accuracy specifications include errors caused by the thermal gradient across the IOM3.3 terminals for configurations with the IOM3.3 terminals facing forward or upward.</li> </ul>
<b>Terminal connections</b>	<p>Terminals: Standard 45° plug, 1.5 mm<sup>2</sup></p> <p>Wiring: 0.1 to 1.5 mm<sup>2</sup> (28 to 16 AWG), multi-stranded</p>
<b>Torques and terminals</b>	<p>Module faceplate screws: 0.5 N·m (4.4 lb-in)</p> <p>Connection of wiring to relay output terminals: 0.5 N·m (4.4 lb-in)</p> <p>Connection of wiring to input terminals: 0.25 N·m (2.2 lb-in)</p> <p>UL/cUL Listed: Wiring must be minimum 90 °C (194 °F) copper conductors only</p>
<b>Galvanic isolation</b>	<p>All 10 multi inputs have a common ground</p> <p>Galvanic isolation from rack: 600 V, 50 Hz for 60 s</p>
<b>Dimensions</b>	L×H×D: 28 × 162 × 150 mm (1.1 × 6.4 × 5.9 in)
<b>Weight</b>	164 g (0.4 lb)

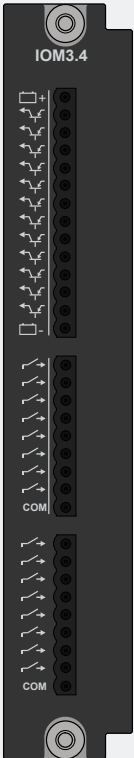

### 3.3.11 Input/output module IOM3.4

The input output module has 12 digital outputs, and 16 digital inputs. These I/Os are all configurable.

### IOM3.4 terminals

Module	Count	Symbol	Type	Name
	12		Digital output	Configurable
	16		Digital input	Configurable

### IOM3.4 technical specifications





Category	Specification
<b>Digital outputs</b> 	Transistor type: PNP Supply voltage: 12 or 24 V DC nominal, maximum 36 V DC (relative to common) Maximum current (per output): < 55 °C: 250 mA; > 55 °C: 200 mA Leak current: Typical 1 µA, maximum 100 µA (temperature-dependent) Saturation voltage: Maximum 0.5 V Non-replaceable 4 A fuse Voltage withstand: ±36 V DC Load dump protected by TVS diodes Short circuit protection Reverse polarity protection Internal freewheeling diode
<b>Digital inputs</b> 	Bipolar inputs <ul style="list-style-type: none"> <li>ON: -36 to -8 V DC, and 8 to 36 V DC</li> <li>OFF: -2 to 2 V DC</li> </ul> Minimum pulse length: 50 ms Impedance: 4.7 kΩ Voltage withstand: ±36 V DC
<b>Terminal connections</b>	Terminals: Standard 45° plug, 1.5 mm <sup>2</sup> Wiring: 0.1 to 1.5 mm <sup>2</sup> (28 to 16 AWG), multi-stranded
<b>Torques and terminals</b>	Module faceplate screws: 0.5 N·m (4.4 lb-in) Connection of wiring to terminals: 0.25 N·m (2.2 lb-in) UL/cUL Listed: Wiring must be minimum 90 °C (194 °F) copper conductors only
<b>Galvanic isolation</b>	Between groups: 600 V, 50 Hz for 60 s
<b>Ingress protection</b>	Unmounted: No protection rating Mounted in rack: IP20 according to IEC/EN 60529

Category	Specification
Dimensions	L×H×D: 28 × 162 × 150 mm (1.1 × 6.4 × 5.9 in)
Weight	175 g (0.4 lb)

### 3.3.12 Processor and communication module PCM3.1

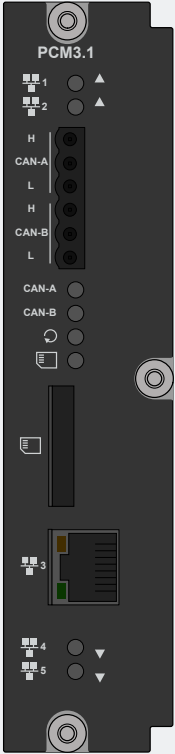
The processor and communication module has the controller's main microprocessor, which contains and runs the controller application software. It includes the Ethernet switch to manage the controller Ethernet connections, with five 100BASE-TX Ethernet connections. It has a *Self-check OK* LED. It also has two sets of CAN bus terminals and SD card. The PCM3.1 performs time synchronisation with an NTP server.

#### PCM3.1 terminals

Module	Count	Symbol	LED	Type	Name
	5		<ul style="list-style-type: none"> <li>● <b>Off</b> : No communication</li> <li>● <b>Green</b> : Communication connected</li> <li>● <b>Green flash</b> : Active communication</li> </ul>	Ethernet (RJ45)	External network and DEIF network LEDs on the front of the hardware module. Two connections at the top of the hardware module, one on the front, and two at the bottom.
	2	H, CAN-A, L H, CAN-B, L	<ul style="list-style-type: none"> <li>● <b>Off</b> : No communication</li> <li>● <b>Green</b> : CAN connected</li> <li>● <b>Green flash</b> : Active CAN communication</li> </ul>	CAN bus connection	CAN bus
	1		<ul style="list-style-type: none"> <li>● <b>Off</b> : Self-check not OK</li> <li>● <b>Green</b> : Self-check OK</li> <li>● <b>Green flash</b> : In service mode</li> </ul>		
	1		<ul style="list-style-type: none"> <li>● <b>Off</b> : No access</li> <li>● <b>Green flash</b> : Read or write to SD card</li> </ul>	SD card (industrial grade) *	External memory

**NOTE** \* To meet the temperature and EMC specifications, you must use an industrial grade SD card.

#### PCM3.1 technical specifications

Category	Specification
CAN terminals	Voltage withstand: ±24 V DC
Galvanic isolation	Between CAN A and other I/Os: 600 V, 50 Hz for 60 s Between CAN B and other I/Os: 600 V, 50 Hz for 60 s Between Ethernet ports and other I/Os: 600 V, 50 Hz for 60 s
RTC	Real time clock with replaceable lithium battery (replacement recommended every 5 years).
Communication connections	CAN communication terminals: Standard 45° plug, 1.5 mm <sup>2</sup> Wiring: 0.5 to 1.5 mm <sup>2</sup> (28 to 16 AWG), multi-stranded DEIF network: RJ45. Use an Ethernet cable that meets or exceeds the SF/UTP CAT5e specifications. 100BASE-TX.
Torques and terminals	Module faceplate screws: 0.5 N·m (4.4 lb-in) Connection of wiring to terminals: 0.5 N·m (4.4 lb-in) UL/cUL Listed: Wiring must be minimum 90 °C (194 °F) copper conductors only

Category	Specification
Processor	400 MHz 32-bit PowerPC CPU
Memory	256 MB
Storage	512 MB
Ingress protection	Unmounted: No protection rating Mounted in rack: IP20 according to IEC/EN 60529
Dimensions	L×H×D: 36.8 × 162 × 150 mm (1.4 × 6.4 × 5.9 in)
Weight	214 g (0.5 lb)

### 3.3.13 Blind module

A blind module must be used to close off each empty slot in the rack.

#### Blind module technical specifications

Category	Specification
Tightening torque	Module faceplate screws: 0.5 N·m (4.4 lb-in)
Dimensions	L×H×D: 28 × 162 × 18 mm (1.1 × 6.4 × 0.7 in)
Weight	44 g (0.1 lb)

## 3.4 Display unit DU 300 specifications

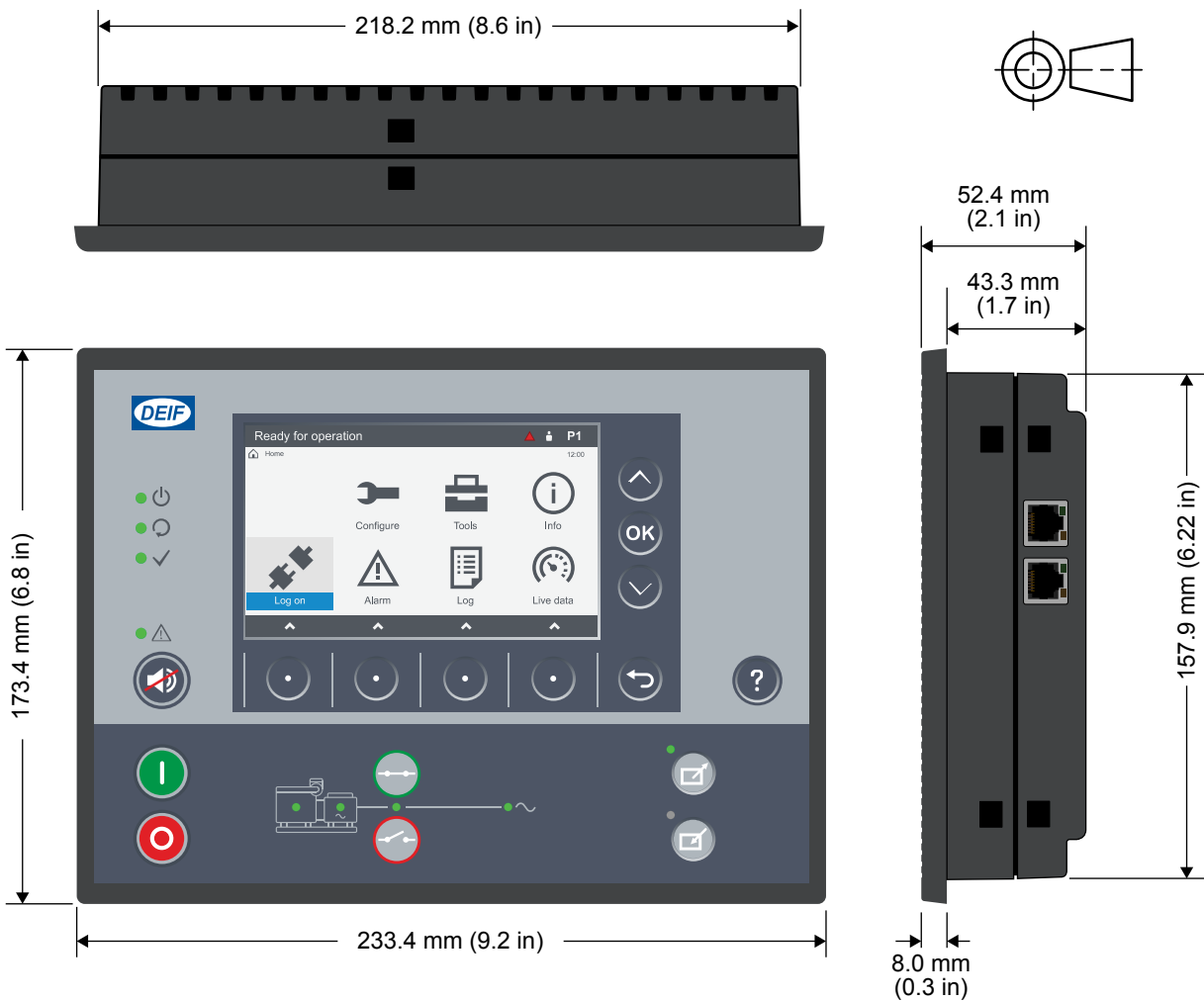

### 3.4.1 Display unit DU 300





#### Dimensions and weight specifications

Category	Specifications
Dimensions	L×H×D: 233.4 × 173.4 × 52.4 mm (9.2 × 6.8 × 2.1 in) (outer frame) Panel cutout, L×H: 220 × 160 mm (8.7 × 6.3 in)
Weight	835 g (1.8 lb)

#### Technical specifications

Category	Specifications
Ingress protection	From the front: IP65 according to IEC/EN 60529 From the back: IP20 according to IEC/EN 60529
UL/cUL Listed	Type Complete Device, Open Type 1
Frame ground 	Voltage withstand: ±36 V DC to the power supply positive (terminal 1) and negative (terminal 2)
Power supply 	Input voltage: 12 or 24 V DC nominal (8 to 36 V DC continuously) UL/cUL Listed: 10 to 32.5 V DC 0 V DC for 50 ms when coming from at least 8 V DC (cranking dropout) Consumption: Typical 4 W, maximum 12 W Internal protection: 12 A slow-blow fuse (not replaceable) (fuse size determined by load dump requirements) Voltage withstand: ±36 V DC

Category	Specifications
	Load dump protected by TVS diodes  <b>Start current</b> <ul style="list-style-type: none"> <li>Power supply current limiter               <ul style="list-style-type: none"> <li>24 V: 2.1 A minimum</li> <li>12 V: 4.2 A minimum</li> </ul> </li> <li>Battery: No limit</li> </ul>
<b>Relay output</b> 	Relay type: Electromechanical Electrical rating and UL/cUL Listed: 30 V DC and 1 A, resistive Voltage withstand: ±36 V DC
<b>Relay output</b> 	Relay type: Solid state Electrical rating and UL/cUL Listed: 30 V DC and 1 A, resistive Voltage withstand: ±36 V DC
<b>Terminal connections</b>	<b>Frame ground and power supply:</b> <ul style="list-style-type: none"> <li>Terminals: Standard plug, 2.5 mm<sup>2</sup></li> <li>Wiring: 1.5 to 2.5 mm<sup>2</sup> (16 to 12 AWG), multi-stranded</li> </ul> <b>Other connections:</b> <ul style="list-style-type: none"> <li>Terminals: Standard plug, 2.5 mm<sup>2</sup></li> <li>Wiring: 0.5 to 2.5 mm<sup>2</sup> (22 to 12 AWG), multi-stranded</li> </ul>
<b>Communication connections</b>	DEIF network: RJ45. Use an Ethernet cable that meets or exceeds the SF/UTP CAT5e specifications, 100BASE-TX
<b>Torques and terminals</b>	Display unit fixing screw clamps: 0.15 N·m (1.3 lb-in) Connection of wiring to terminals: 0.5 N·m (4.4 lb-in) UL/cUL Listed: Wiring must be minimum 90 °C (194 °F) copper conductors only
<b>Galvanic isolation</b>	Between power supply, relay groups, and network plugs: 600 V, 50 Hz for 60 s

## 3.5 Accessory specifications

### 3.5.1 Ethernet cable

The Ethernet cable from DEIF meets the technical specifications below.

Category	Specification
<b>Cable type</b>	Shielded patch cable SF/UTP CAT5e
<b>Temperature</b>	Fixed installation: -40 to 80 °C (-40 to 176 °F) Flexible installation: -20 to 80 °C (-4 to 176 °F)
<b>Minimum bending radius (recommended)</b>	Fixed installation: 25 mm (1 in) Flexible installation: 50 mm (2 in)
<b>Length</b>	2 m (6.6 ft)
<b>Weight</b>	~110 g (4 oz)

## 4. Ordering

### 4.1 PPU 300 controller ordering

#### Controller hardware configuration, standard controller

Each controller is always supplied with a PSM3.1, ACM3.1 and PCM3.1 module. Depending on the controller type ordered, other modules are added. The factory selection of additional modules can be made when ordering.

A display unit can be ordered directly along with the controller (see [type selection](#) in table 4.4).

#### Standard controller without CODESYS

The standard controller can via display or PC software PICUS be selected to be one of the following types:

- Diesel generator controller.
- Shaft generator controller.
- Bus tie breaker controller.
- Shore connection controller.

**Rack size:** 7-slot

**Item number:** 2912210060.01

**Rack size:** 4-slot

**Item number:** 2912210060.07

**Table 4.1** Controller configuration, standard controller without CODESYS

Rack	Slot 1	Slot 2	Slot 3	Slot 4	Slot 5	Slot 6	Slot 7
R7.1	PSM3.1	ACM3.1	IOM3.1/ Selectable	GAM3.1/ Selectable	Selectable	Selectable	PCM3.1
R4.1	PSM3.1	ACM3.1	IOM3.1/ Selectable	PCM3.1	N/A	N/A	N/A

#### Standard controller with CODESYS

**Rack size:** 7-slot

**Item number:** 2912210060.06

**Rack size:** 4-slot

**Item number:** 2912210060.09

**Table 4.2** Controller configuration, standard controller with CODESYS

Rack	Slot 1	Slot 2	Slot 3	Slot 4	Slot 5	Slot 6	Slot 7
R7.1	PSM3.1	ACM3.1	Selectable	Selectable	Selectable	Selectable	PCM3.1
R4.1	PSM3.1	ACM3.1	Selectable	PCM3.1	N/A	N/A	N/A

#### Controller Hardware, Hybrid controller

The Hybrid controller can be used as a battery bank (ESS, Energy Storage System) controller, controlling the battery inverter. It can also be used for a shaft generator, provided it is fitted with an inverter.

A display unit can be ordered along with the controller (see [type selection](#) in table 4.4).

**Rack size:** 7-slot

**Item number:** 2912210060.13

**Table 4.3** Controller configuration, Hybrid controller

Rack	Slot 1	Slot 2	Slot 3	Slot 4	Slot 5	Slot 6	Slot 7
R7.1	PSM3.1	ACM3.1	IOM3.1/ Selectable	GAM3.1/ Selectable	Selectable	Selectable	PCM3.1

**Display unit selection**

These selections are for standard unit displays. The Hybrid controller display always comes with the Hybrid folio.

**Table 4.4** Display unit selection

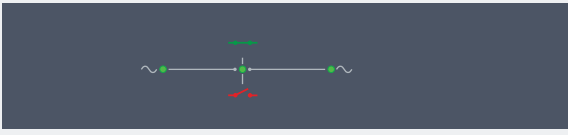
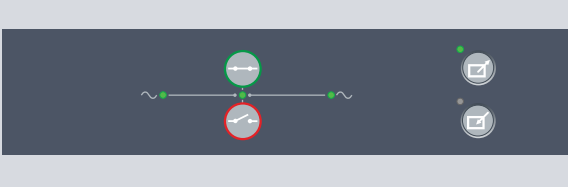
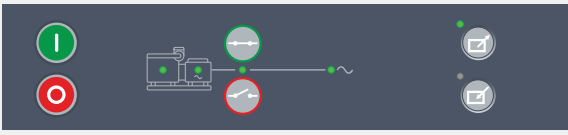
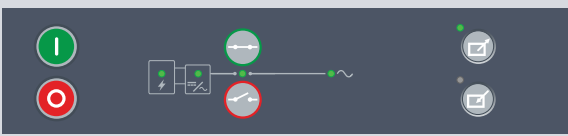
Options	Folio *	Notes
Blank		Blank display unit folio. Used for: Read data only, no breaker feedback, no control.
CB w/o CTRL		Display unit folio with application LEDs. Used for: Read data and see status and position, no control.
CB CTRL		Display unit folio with breaker push-buttons. Used for: <ul style="list-style-type: none"> <li>• Shaft generator control.</li> <li>• Bus tie breaker control.</li> <li>• Shore connection control.</li> </ul>
DG + CB CTRL		Display unit folio with full functionality. Used for: Generator control.
HYBRID		Display unit folio with full functionality. Used for: Inverter control.

**NOTE** \* Only bottom part of display is shown, the top part is always the same.

**4.2 Extension rack ordering**

The Extension rack comes as standard with PSM3.2 module mounted.

**Extension rack configuration**

**Rack size:** 7-slot or 4-slot

**Item number:** 2912990350.01

**Table 4.5** Extension rack configuration

Rack	Slot 1	Slot 2	Slot 3	Slot 4	Slot 5	Slot 6	Slot 7
R7.1	PSM3.2	Selectable	Selectable	Selectable	Selectable	Selectable	Selectable
R4.1	PSM3.2	Selectable	Selectable	Selectable	N/A	N/A	N/A

## 4.3 Modules for controller configuration

The following table lists parts/accessories/spare parts for a PPU 300 controller.

Module	Terminals	Comment	Item no.	Options
DU 300	-	Display unit for PPU 300.	2912990240.01	Blank
				CB w/o CTRL
				CB CTRL
				DG + CB CTRL
				HYBRID
R7.1	-	7-slot rack for use as controller or extension rack.	2912990240.09	-
R4.1	-	4-slot rack for use as controller or extension rack.	2912990240.41	-
PSM3.1	<b>Power Supply Module (main rack)</b> <ul style="list-style-type: none"> <li>1 × Power supply</li> <li>3 × Relay outputs (2 x configurable)</li> <li>2 × RJ45 EtherCAT communication ports</li> </ul>	For use in controller rack.	2912990240.07	-
PSM3.2	<b>Power Supply Module (extension rack)</b> <ul style="list-style-type: none"> <li>1 × Power supply</li> <li>3 × Relay outputs (2 x configurable)</li> <li>2 × RJ45 EtherCAT communication ports</li> </ul>	For use in extension racks.	2912990240.42	-
ACM3.1	<b>AC voltage and current module</b> <ul style="list-style-type: none"> <li>2 × 3-phase voltage measurements</li> <li>1 × 3-phase and 4th current measurements</li> </ul>	A maximum of one ACM3.1 module is allowed per controller (including extension racks).	2912990240.03	-
ACM3.2	<b>Differential current module</b> <ul style="list-style-type: none"> <li>1 × 3-phase current measurement - Consumer side</li> <li>1 × 3-phase current measurement - Neutral side</li> </ul>	A maximum of one ACM3.2 module is allowed per controller (including extension racks).	2912990240.40	-
IOM3.1	<b>Input Output Module</b> <ul style="list-style-type: none"> <li>4 × Changeover relays</li> <li>10 × Digital inputs</li> </ul>		2912990240.05	-
IOM3.2	<b>Input Output Module</b> <ul style="list-style-type: none"> <li>4 × Relay outputs</li> <li>2 × Analogue multifunctional outputs (mA, V DC, PWM)</li> <li>2 × Analogue multifunctional outputs (mA, V DC)</li> <li>4 × Digital inputs</li> <li>4 × Analogue multifunctional inputs (mA, V DC, RMI)</li> </ul>		2912990240.44	-
IOM3.3	<b>Input Output Module</b>		2912990240.45	-

Module	Terminals	Comment	Item no.	Options
	<ul style="list-style-type: none"> <li>10 x Analogue multifunctional inputs (mA, V DC, RMI)</li> </ul>			
IOM3.4	<b>Input Output Module</b> <ul style="list-style-type: none"> <li>12 x Transistor outputs</li> <li>16 x Digital inputs</li> </ul>		2912990240.25	-
EIM3.1	<b>Engine Interface Module</b> <ul style="list-style-type: none"> <li>1 x Power supply</li> <li>4 x Relay outputs (1 with wire break detection)</li> <li>4 x Digital inputs</li> <li>1 x MPU input</li> <li>1 x W input</li> <li>3 x Current/resistance analogue inputs</li> </ul>	A maximum of three EIM3.1 modules are allowed per controller (including extension units).	2912990240.04	-
GAM3.1	<b>Governor and AVR Module</b> <ul style="list-style-type: none"> <li>4 x Relay outputs</li> <li>2 x Current/voltage analogue outputs</li> <li>1 x PWM output</li> <li>2 x Current/voltage analogue inputs</li> </ul>	A maximum of three GAM3.1 and/or GAM3.2 modules are allowed per controller (including extension units).	2912990240.06	-
GAM3.2	<b>Governor and AVR Module</b> <ul style="list-style-type: none"> <li>1 x Power supply</li> <li>2 x Current/voltage analogue outputs</li> <li>1 x PWM output</li> <li>5 x Digital inputs</li> <li>5 x Relay outputs</li> </ul>	A maximum of three GAM3.1 and/or GAM3.2 modules are allowed per controller (including extension units).	2912990240.26	-
PCM3.1	<b>Processor and Communication Module</b> <ul style="list-style-type: none"> <li>5 x Ethernet communication ports</li> <li>2 x CAN bus connections</li> <li>1 x SD card slot</li> </ul>		2912990240.46	-
Blind	Blind module	Not allowed between PSM3.1 and the optional modules.	2912990240.08	-
Blind small	Small blind module	One needed for extension rack	2912990240.43	-
Shielded patch cable	-	SF/UTP CAT5e	2912990240.14	-
Terminal blocks	Terminal blocks for Multi-line 300		2912990240.38	-

## 5. Legal information

### 5.1 Disclaimer and copyright

#### Open source software

This product contains open source software licensed under, for example, the GNU General Public License (GNU GPL) and GNU Lesser General Public License (GNU LGPL). The source code for this software can be obtained by contacting DEIF at support@deif.com. DEIF reserves the right to charge for the cost of the service.

#### Trademarks

*DEIF* and the DEIF logo are trademarks of DEIF A/S.

*BELDEN* is a trademark of BELDEN INC.

*Bonjour*<sup>®</sup> is a registered trademark of Apple Inc. in the United States and other countries.

*Adobe*<sup>®</sup>, *Acrobat*<sup>®</sup>, and *Reader*<sup>®</sup> are either registered trademarks or trademarks of Adobe Systems Incorporated in the United States and/or other countries.

*CANopen*<sup>®</sup> is a registered community trademark of CAN in Automation e.V. (CiA).

*SAE J1939*<sup>®</sup> is a registered trademark of SAE International<sup>®</sup>.

*CODESYS*<sup>®</sup> is a trademark of CODESYS GmbH.

*EtherCAT*<sup>®</sup>, *EtherCAT P*<sup>®</sup>, *Safety over EtherCAT*<sup>®</sup>, are trademarks or registered trademarks, licensed by Beckhoff Automation GmbH, Germany.

*Modbus*<sup>®</sup> is a registered trademark of Schneider Automation Inc.

*Windows*<sup>®</sup> is a registered trademark of Microsoft Corporation in the United States and other countries.

All trademarks are the properties of their respective owners.

#### Copyright

© Copyright DEIF A/S. All rights reserved.

#### Disclaimer

DEIF A/S reserves the right to change any of the contents of this document without prior notice.

The English version of this document always contains the most recent and up-to-date information about the product. DEIF does not take responsibility for the accuracy of translations, and translations might not be updated at the same time as the English document. If there is a discrepancy, the English version prevails.