

iE 150 PMS lite



About iE 150 PMS lite

The iE 150 PMS lite controllers are for off-grid plants with up to 254 generators and/or bus tie breakers. PMS lite is only for generators - no other power sources are possible. Each PMS lite controller protects and controls a genset, and the genset breaker.

When the plant is running, the operator can see the total available and consumed power on each display, along with an overview of the operating information for all the generators in the plant.

The power management system makes sure that generators are started or stopped according to the load and priority. The controllers make sure that the generators share the load equally.

The PMS lite controller can also be used as a single controller. The controller can protect and control a genset, a genset breaker, and a mains breaker in single-controller applications.

The values and alarms are shown on the LCD display screen, which is sunlight-readable.

PMS lite features

Easy and quick configuration

Configure the plant from the display, without using a PC. Connected PMS lite controllers use CAN bus connections to automatically detect each other and assign IDs. The power management system makes sure the generators are started and stopped according to the load and priority.

PMS lite overview page

The PMS lite overview page shows an overview of the operating information for all the generators. The operator can also see the total available power and the consumer power. Use the left and right arrow buttons on the controller to change between the Power (kW) page and the Reactive power (kvar) page.

Functions

- Generator priority
- Group priority
- Load-dependent start and stop (LDSS)
- PLC start and stop
- PMS lite load sharing
- Single controller applications
- Total configuration possible from the display

Power management

- Balances the loads in the system

Plant

- In a system, each display shows:
 - Operating information for all gensets
 - Total plant load and available power
- Automatically detects and assigns IDs
- Supports different settings in each controller
- Share PMS lite settings between controllers
- Select number of generators to run
- Select to start all generators

Generator priority

- Assigned automatically or manually

Load-dependent start and stop (LDSS)

- Automatically starts the next generator for high load
- Automatically stops the next generator for low load
- Select minimum number of running generators

PLC controlled start and stop

- You can use a PLC to control genset start and stop
- When the controller is in PLC control it ignores the settings for load-dependent start and stop

Group priority

- Group gensets together based on their priority. For example, two gensets with the same priority are grouped together and will start at the same time.

Single controller

- Use a single controller to protect and control a genset, a genset breaker, and a mains breaker
- Operation modes:
 - Automatic mains failure (AMF)
 - Fixed power
 - Peak shaving
 - Load take-over
 - Mains power export (MPE)
- Requires a mains power measurement to do peak shaving, load take-over and mains power export
- Cannot be part of a power management system with other controllers

Application examples

Power management applications (multiple gensets)

PMS lite, with interlinked busbars, and up to 254 single gensets and/or bus tie breakers

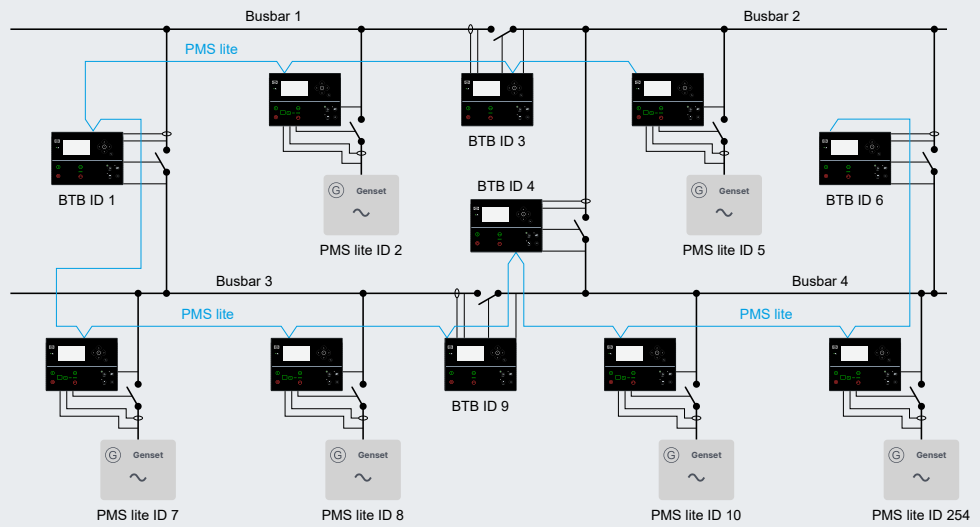

PMS lite, with gensets only

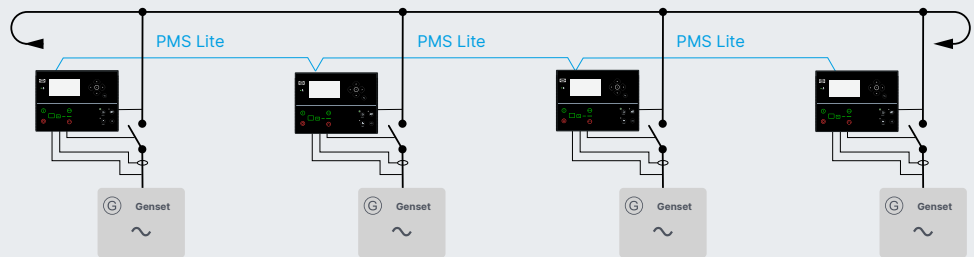

PMS lite, with genset groups

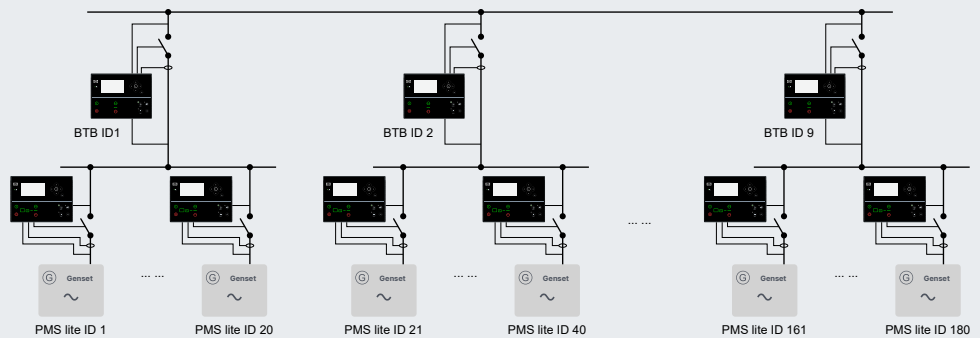

NOTE PMS lite controllers can only be used with other PMS lite controllers.

NOTE iE 150 PMS lite can be used with the standard BTB controller. However, it cannot be used with the other power management system controllers. To control gensets in a standard power management system, use iE 150 Generator or AGC 150 Generator controllers.

Key functions

Engine

- Engine start sequences
- Configurable run coil and crank for electric engine
- Stage V and Tier 4 support
- Support for diesel and gas gensets
- Fuel usage monitoring
- Maintenance alarms

Generator

- 3-phase genset and busbar sensing
- 4 x current sensing inputs
- Synchroscope and sync check
- Support for various digital voltage regulators
- Integrated governor and AVR outputs
- Voltage and frequency matching
- Dynamic synchronisation
- Dead bus sensing

Single controller

- Mains support for stand-alone systems (AMF)

Easy to use

- Controller configuration possible from the display
- PC tool with trending is available
- User-configurable logic (lite PLC)
- CAN flags between controllers
- 20+ configurable graphical screens
- Multiple language support
- Event log with 500 entries
- Alarm log with 500 entries

Other

- CAN bus based extension I/O module
- Real-time clock

Typical wiring

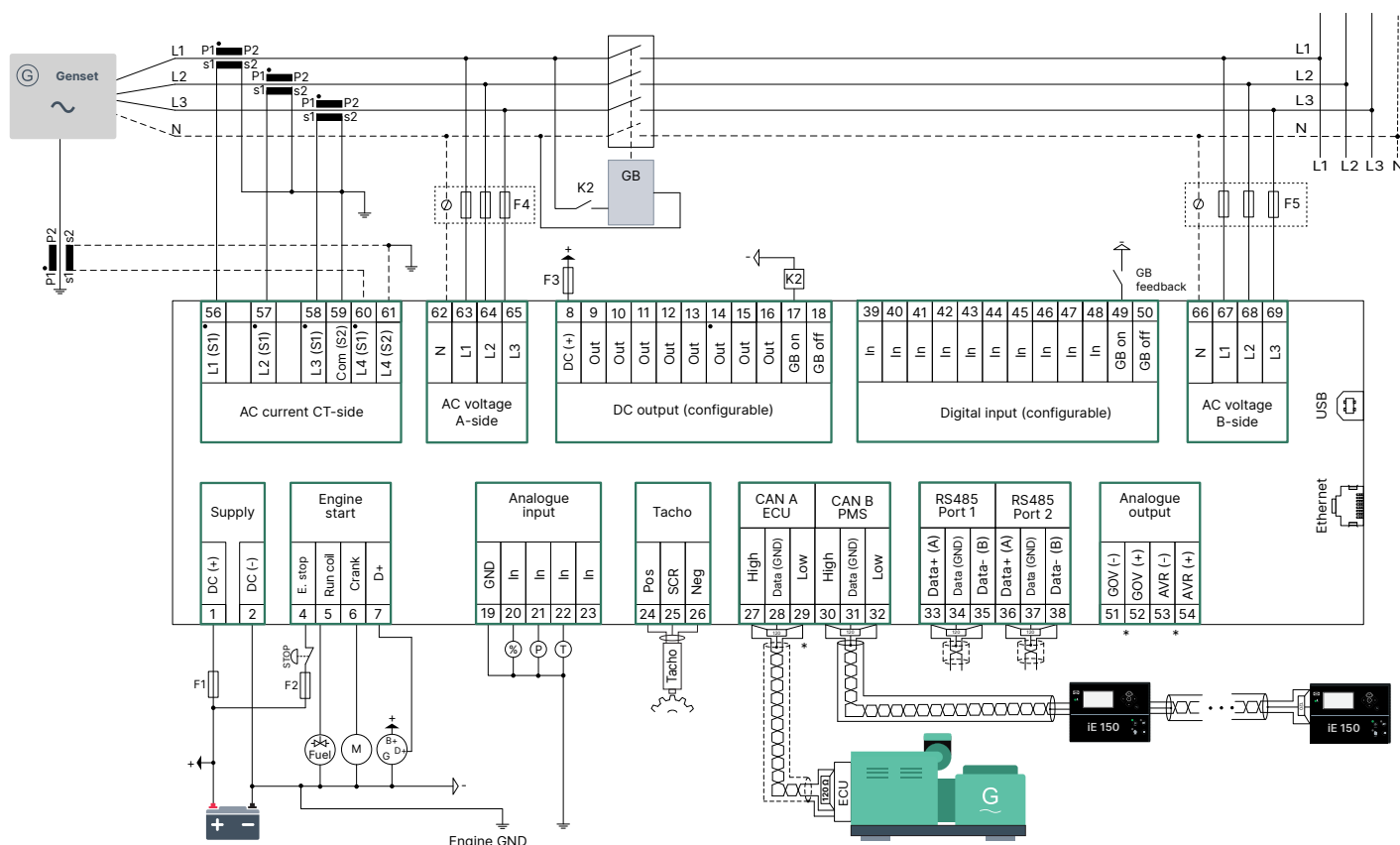

NOTE * The diagram shows EIC governor regulation. Alternatively, the governor and AVR can be regulated using the analogue outputs.

Technical specifications

Communication

- CAN A
- CAN B
- RS-485 Port 1
- RS-485 Port 2
- RJ45 Ethernet
- USB

AC measuring

- Voltage: 100 to 690 V phase-to-phase (10 to 135 %), ± 1 %
- Current: 1 A or 5 A (2 to 300 %), ± 1 %
- Frequency: 3.5 to 75 Hz

Power supply

- Nominal voltage: 12/24 V DC
- Operating range: 6.5 to 36 V DC
- Load dump protection: ISO16750-2
- Operating range: 6.5 to 36 V DC

Inputs and outputs

- Digital inputs: 12 x (max. +36 V, min. -24 V)
- Digital outputs:
 - 2 x (15 A inrush, 3 A continuously)
 - 10 x (2 A inrush, 0.5 A continuously)
 - Common: 12/24 V DC
- 4 x analogue inputs

Environmental specifications

- Operating temperature: -40 to +70 °C (-40 to +158 °F)
- Storage temperature: -40 to +85 °C (-40 to +185 °F)
- Altitude: 0 to 4000 m with derating
- Humidity: 20/55 °C at 97 %
- Protection degree: IP65 in panel, IP20 on terminals
- Pollution degree 2
- Self-extinguishing plastic

Approvals

- CE
- UL/cUL Listed to UL/ULC6200:2019, 1. ed. Controllers for Use in Power Production

NOTE Refer to deif.com for the most recent approvals.

Protections

3 x Reverse power.....	ANSI 32R
2 x Fast over-current.....	ANSI 50P
4 x Over-current.....	ANSI 50TD
1 x Voltage-dependent over-current.....	ANSI 50V
2 x Over-voltage.....	ANSI 59
3 x Under-voltage.....	ANSI 27P
3 x Over-frequency.....	ANSI 81O
3 x Under-frequency.....	ANSI 81U
1 x Unbalance voltage.....	ANSI 47
1 x Unbalance current.....	ANSI 46
1 x Under-excitation or reactive power import....	ANSI 32RV
1 x Over-excitation or reactive power export.....	ANSI 32FV
5 x Overload*.....	ANSI 32F
1 x Inverse time earth over-current.....	ANSI 50G
1 x Inverse time neutral over-current.....	ANSI 50N
3 x Busbar over-voltage.....	ANSI 59P
4 x Busbar under-voltage.....	ANSI 27P
3 x Busbar over-frequency.....	ANSI 81O
4 x Busbar under-frequency.....	ANSI 81U
1 x Low auxiliary supply.....	ANSI 27DC
1 x High auxiliary supply.....	ANSI 59DC
1 x Breaker open failure.....	ANSI 52BF
1 x Breaker close failure.....	ANSI 52BF
1 x Breaker position failure.....	ANSI 52BF
1 x Phase sequence error.....	ANSI 47
1 x ROCOF (df/dt).....	ANSI 81R
1 x Power-dependent reactive power.....	ANSI 40
1 x Emergency stop	
1 x Generator breaker external trip	
1 x Synchronisation failure alarms	
1 x De-load error	
1 x Hz/V failure	
1 x Not in Auto	
Single controller: 2 x Mains over-current (4th CT)	
Single controller: 2 x Mains reverse power (4th CT)	
Single controller: 2 x Mains overload (4th CT)	

NOTE * You can configure these protections for overload or reverse power.



Scan to learn
more about DEIF

DEIF A/S
Frisenborgvej 33
DK-7800 Skive

+45 9614 9614
info@deif.com
deif.com