

iE 250 Marine

Intelligent energy controller

Data sheet

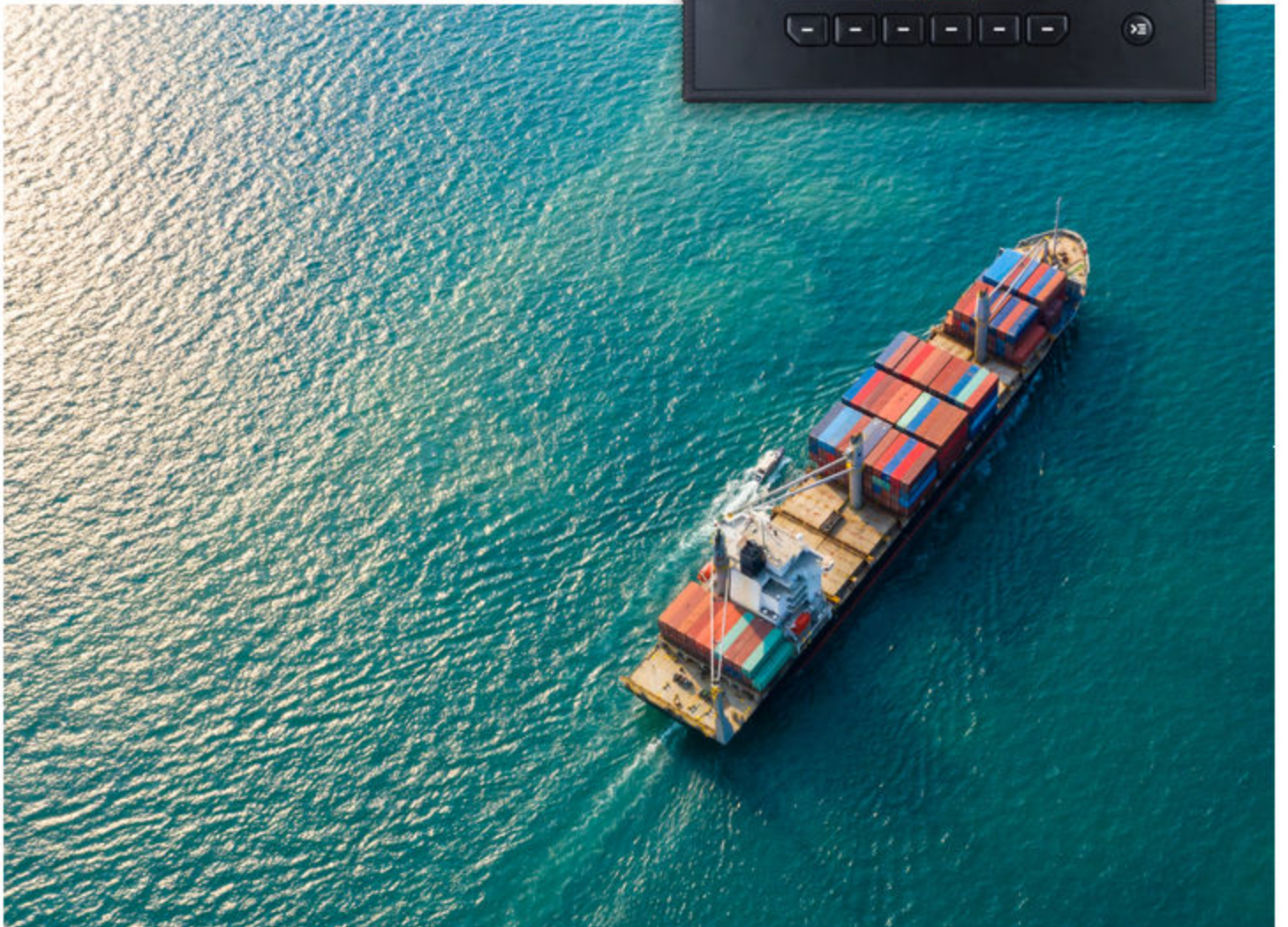

1. Intelligent energy controller

1.1 About the controller	4
1.1.1 Licences and supported features.....	4
1.1.2 About the controller types.....	4
1.1.3 Software versions.....	5
1.1.4 Display layout.....	6
1.1.5 Emulation.....	6
1.2 Functions and features	7
1.2.1 Software licences.....	7
1.2.2 General functions and features.....	7
1.3 Alarms and protections	14
1.3.1 Alternating current (AC) protections.....	14
1.4 Applications	17
1.4.1 Applications.....	17
1.4.2 Extension rack functions.....	18
1.5 Compatible products	18
1.5.1 DEIF digital voltage controllers (DVC).....	18
1.5.2 Additional inputs and outputs.....	19
1.5.3 Other equipment.....	20

2. Technical specifications

2.1 Dimensions	21
2.1.1 iE 250 (7"): Front-mounted controller with MIO2.1.....	21
2.1.2 iE 250 (Base): Base-mounted controller with MIO2.1.....	22
2.1.3 iE 7 display.....	23
2.1.4 Plug-in module for 8 Digital bi-directional channels (PIM-8DIO).....	24
2.1.5 Plug-in module for 4 Analogue bi-directional channels (PIM-4AIO).....	25
2.2 Mechanical specifications	26
2.2.1 iE 250 (7"): Front-mounted controller with MIO2.1.....	26
2.2.2 iE 250 (Base): Base-mounted controller with MIO2.1.....	27
2.2.3 iE 7 display.....	28
2.3 Environmental specifications	29
2.3.1 iE 250 (7"): Front-mounted controller with MIO2.1.....	29
2.3.2 iE 250 (Base): Base-mounted controller with MIO2.1.....	29
2.3.3 iE 7 display.....	29
2.4 Controller	31
2.4.1 Terminal connections.....	31
2.4.2 Electrical specifications.....	31
2.4.3 Communication specifications.....	33
2.5 iE 7 display	34
2.5.1 Terminal connections.....	34
2.5.2 Electrical specifications.....	34
2.5.3 Communication specifications.....	34
2.6 Measurement Input Output module (MIO2.1)	36
2.6.1 About.....	36
2.6.2 Terminal connections.....	36
2.6.3 Electrical specifications.....	37
2.6.4 Communication specifications.....	39
2.7 Plug-in module for 8 Digital bi-directional channels (PIM-8DIO)	40
2.8 Plug-in module for 4 Analogue bi-directional channels (PIM-4AIO)	41

2.9 Accessories	42
2.9.1 DIN rail clamps.....	42
2.9.2 USB type A to C cable.....	42
2.9.3 DisplayPort cable.....	42
2.9.4 Ethernet cable.....	42
2.10 Approvals	43
2.11 Cybersecurity	43
3. Legal information	
3.1 Disclaimer and copyright	44

1. Intelligent energy controller

1.1 About the controller

1.1.1 Licences and supported features

The supported features shown in this document depend on the software licence installed.

The standard license is the **Core** licence including synchronising and load share, and support. Alternatively, you can select the **Power management** licence, which includes power management features and support.



Example

Controllers with the Power management licence can be included in a power management system. A power management system can include a number of controllers. The controllers work together to ensure effective power management. This can include load-dependent start and stop, and may include setting the genset priority order, managing heavy consumers, and, if necessary, tripping non-essential loads.

1.1.2 About the controller types

The iE 250 is a versatile and modular-designed controller for marine. Its design enables you to tailor the installation to your needs.

Available hardware versions:

- **iE 250 Marine (7")**: Front-mounted version with 7" touchscreen.
- **iE 250 Marine (Base)**: Base-mounted version for DIN rail or fixed (180° rotated) mounting in back panel.

Front-mounted controller with combined display



iE 250 Marine (7")

Base-mounted controller with or without display

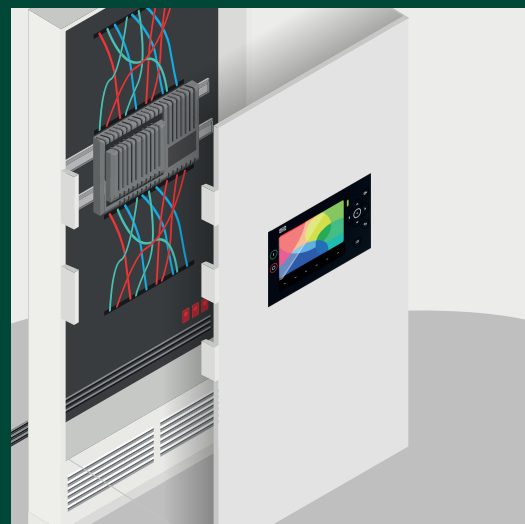

iE 250 Marine (Base)

iE 7 display

An extensive range of control, protection and supervision features. Applications range from generator control and protection to engineered power management solutions.

The supported features depend on the software licence installed.

Each controller is assigned a type from the factory. You can see the type of controller on the single-line application drawing.

Controller type	Controls and protects
Genset controller	A prime mover, generator, and generator breaker.
Emergency genset controller *	An emergency prime mover, generator, and both generator breaker and busbar tie breaker. There can only be 1 Emergency generator controller in each system.
Hybrid controller	An inverter with power source, and breaker.
Bus tie breaker controller	A bus tie breaker.
Shaft generator controller	The system when a shaft generator is connected.
Shore connection controller	The system and a shore connection breaker, when a shore connection is connected.

NOTE * Emergency genset controllers are only available with the Power management licence.

1.1.3 Software versions





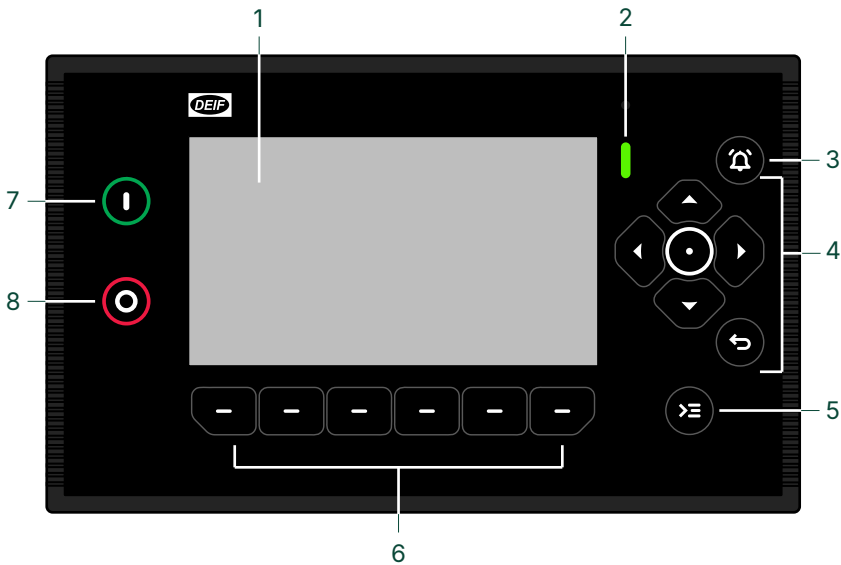

The information in this document relates to software versions:

Software	Details	Version
iE 250 Marine Core iE 250 Marine Power management	Controller application	2.0.11.x
CODESYS libraries	CODESYS	2.0.11.x
PICUS	PC software	1.0.24.x

1.1.4 Display layout

The base-mounted controller can run with or without a display, but we recommend that you use an iE 7 display. The display is the operator's interface to the controller.



No.	Item	Notes
1	Display screen	7" colour touch screen.
2	Status LED	Multi-colour LED for status indication.
3	 Notification centre button	Silences the alarm horn (deactivates the output), and opens the Notification centre , which shows alarms and events.
4	Navigation buttons	Up, down, left, and right arrows.
	 Enter button	Confirms the selection.
	 Back button	<ul style="list-style-type: none"> Returns to the previous page Shows the menu. Hold: Change to Dashboard
5	 Control centre button	Opens the Control centre .
6	Configurable buttons	Buttons can be activated either by pressing the physical button or the soft key on the screen. *
7	 Start button	In manual or local operation, it starts the asset. In a Power management system and in AUTO mode, it starts the Power management.
8	 Stop button **	In manual or local operation, it stops the asset. In a Power management system and in AUTO mode, it stops the Power management.

NOTE * Dashboard pages can be created, copied and modified, to assign different functions to the buttons (with PICUS and the Display designer).

** Double press to override cooldown process. Press again to cancel **Idle run**, if configured. Idle run may not be permitted or approved by certain maritime classification societies.

1.1.5 Emulation

iE 250 includes an emulation tool to verify and test the functionality of the application, for example plant modes and logic, breaker handling, shore and generator operation.

Application emulation is useful for training, customising plant requirements and for testing basic functionality that needs to be set up or verified.

In a power management system it is possible to control the entire plant, when connected to just one of the controllers.

1.2 Functions and features

1.2.1 Software licences

The supported features depend on the software licence installed.

The standard license is the **Core** licence synchronising and load share, and support. Alternatively, you can select the **Power management** licence, which includes power management features and support.

1.2.2 General functions and features

Modular and configurable design	
Mounting choices	Choice of either: <ul style="list-style-type: none"> • iE 250 Marine (7") Front-mounted • iE 250 Marine (Base) Base-mounted
Display	iE 7 display <ul style="list-style-type: none"> • For base-mounted
New design – easy mount	Front-mounted controller or display has same cut-out footprint as the iE 150 and AGC 150.
Easy expansion	<p>Add-on modules</p> <ul style="list-style-type: none"> • Measurement Input Output module MIO2.1. <p>Plug-in modules</p> <ul style="list-style-type: none"> • 8 Digital bi-directional channels (PIM-8DIO). • 4 Analogue bi-directional channels (PIM-4AIO). <p>Additional input/output possibilities</p> <ul style="list-style-type: none"> • 300 series modules. • 600 series modules with CODESYS .

Load control features	
Control modes	LOCAL (commands from display push-buttons) REMOTE (commands from digital inputs, PICUS, Modbus, CustomLogic, CODESYS)
Load control	Communication over the DEIF network Ethernet. Genset controllers can have equal load sharing. Genset controllers can do asymmetrical load sharing. Genset controllers can synchronise/de-load Mains and BTB controllers. External breaker position feedback. Automatic detection of load sharing busbar sections (including for a ring busbar).

Power management features	
Control modes	<ul style="list-style-type: none"> • AUTO mode: <ul style="list-style-type: none"> ◦ Automatic power management ◦ Automatic load-dependent genset start & stop ◦ Automatic synchronisation & de-loading, and breaker control • MANUAL mode: <ul style="list-style-type: none"> ◦ Operations only on operator command.

Power management features

	<ul style="list-style-type: none"> ◦ Operator-initiated synchronisation and de-loading. ◦ Display control for genset start/stop and breaker open/close. ◦ Display user-configured dashboard soft-key. <p>Change control mode (AUTO/MANUAL) from the display, from PICUS, or via Modbus.</p>
Power management operation	<p>Ethernet-based power management:</p> <ul style="list-style-type: none"> • Up to a total of 32 asset controllers with breakers from: <ul style="list-style-type: none"> ◦ Prime movers and generators (gensets) ◦ Shore connections ◦ Shaft generators ◦ Hybrid controllers ◦ Bus tie breaker controllers • Up to 1 Emergency generator controller. <p>Ethernet network redundancy is possible.</p>
Reliable power	<ul style="list-style-type: none"> • Blackout prevention <ul style="list-style-type: none"> ◦ Precautionary genset/inverter start (either automatically or by operator action). ◦ De-load before opening breakers. ◦ Genset/inverter breaker does not open if this would cause overload or a blackout. • Fast load-reduction. • Configurable recovery after blackout.
Load control	<p>Load control between controllers up to 32 assets.</p> <ul style="list-style-type: none"> • Load transfer (for synchronisation, de-loading and load sharing) • Load-dependent start (two sets of parameters available) <ul style="list-style-type: none"> ◦ For example, Normal start and Faster start (low available power) ◦ Based on active or apparent power, or on percentage of nominal power • Load-dependent stop (two sets of parameters available) <ul style="list-style-type: none"> ◦ For example, Normal stop and Faster stop (high available power) ◦ Based on active or apparent power, or on percentage of nominal power • Power management system calculates control set points <ul style="list-style-type: none"> ◦ Based on system configuration, controller modes, and load sharing. ◦ Frequency, power, voltage, power factor and/or var • External analogue inputs as control set points. <p>Generator controllers can connect or disconnect Heavy consumers (HC). Generator controllers can connect or disconnect Non-Essential Loads (NEL). External breaker position feedback. Automatic detection of load sharing busbar sections (including for a ring busbar).</p>
Priority selection	<ul style="list-style-type: none"> • Set the first priority • Manual <ul style="list-style-type: none"> ◦ Set user-configured dashboard soft-key, digital input, or Modbus ◦ Delayed priority shift • Last priority for genset with digital input or CustomLogic • Dynamic (first genset to connect has the highest priority) • Running hours (Total or trip counters)
Heavy consumer management	<ul style="list-style-type: none"> • Up to 6 fixed and/or variable heavy consumers per controller. • Pre-programmed heavy consumer management sequence (with configurable parameters) • Digital or analogue feedback from the heavy consumer. *

Power management features

Busbar section management	<ul style="list-style-type: none"> Configurable power management rules for each section. Up to 4 externally-controlled breakers per controller * <ul style="list-style-type: none"> Bus tie breakers and/or shore connection breakers. Ring busbar.
Load sharing	<ul style="list-style-type: none"> Active power (kW) load sharing (GOV) Reactive power (kvar) sharing (AVR) Load sharing between gensets: <ul style="list-style-type: none"> Over the DEIF network Load sharing options for each busbar section: <ul style="list-style-type: none"> Equal load sharing (symmetrical). Asymmetric P load sharing for gensets. Asymmetric Q load sharing for gensets. HYBRID inverter with asymmetric load sharing with configurable constant discharge and genset start if required. Shaft generator base load, with asymmetric load sharing for the gensets. Shore connection base load, with asymmetric load sharing for the gensets. One genset base load, with asymmetric load sharing for the other gensets.
Additional features	<p>Generator load-dependent start and stop Asymmetrical generator load sharing Safety stop of generator Flexible application</p>

Application

Single-line application drawing	Flexible applications.
Busbar	Busbar can have a ring connection.
Heavy consumers *	Configurable feedback type and controller.
Non-Essential Loads	Configurable trip signal.
Breakers	Redundant breaker feedback on bus tie breakers. Externally controlled breakers.

NOTE * Available in the Power management licence.

AC configuration features

Nominal settings	4 sets of settings.
AC configuration	<p>Three-phase Three-phase (2 CT, L1L3) Split-phase L1L2 Split-phase L1L3 Split-phase L2L3 Single phase L1 Single phase L2 Single phase L3</p>
4th current	Measurement for earth or neutral protections.
Additional features	<ul style="list-style-type: none"> 100 to 690 V AC (selectable) CT -/1 or -/5 (selectable)

General functions

<p>Regulation</p>	<p>Governor:</p> <ul style="list-style-type: none"> • Active power load sharing • Fixed frequency • Fixed active power • Frequency droop <p>Governor with Power management:</p> <ul style="list-style-type: none"> • Active power load sharing • Frequency regulation • Frequency and phase synchronisation • Fixed power <p>AVR:</p> <ul style="list-style-type: none"> • Reactive power load sharing • Fixed voltage • Fixed reactive power • Fixed cos phi • Voltage droop <p>AVR with Power management:</p> <ul style="list-style-type: none"> • Voltage regulation • Reactive power load sharing • Fixed reactive power • Fixed cos phi <p>Three sets of temperature-dependent power derate settings. Set point selection using digital input, Modbus, and/or CustomLogic or CODESYS. Configurable power ramp up, power ramp down</p>
<p>Pre-programmed sequences</p>	<p>Generator: * Generator start and stop.</p> <p>Breaker: Breaker open sequence (with and without de-loading). Breaker close sequence (with synchronisation). Blackout close. ****</p>
<p>Synchronisation</p>	<p>Automatic synchronisation and de-loading. Operator-initiated synchronisation and de-loading possible. Choose between Static or Dynamic synchronisation. ** De-load before opening.</p>
<p>Breaker control</p>	<p>Breaker types (with configurable parameters): Pulse breaker, Compact breaker, Continuous breaker. Breaker position detection and alarms. Configurable Breaker under-voltage coil setting.</p>
<p>Configurable Idle run ***</p>	<p>Protect the engine with additional warm-up or cooldown periods.</p>
<p>Advanced troubleshooting</p>	<p>Controller self-test. Event and alarm log, with real-time clock.</p>
<p>Event log</p>	<p>The controller stores a maximum of 2000 log entries. When the log is full, the controller discards the excess log entries using first in, first out.</p>
<p>User management</p>	<p>Configurable permission roles and users.</p>
<p>AC measurements</p>	<p>AC measurements can be configured with average filters for use on noisy or oscillating systems for the displayed information. Controller data and calculations are not affected.</p>

General functions	
	Actual values are always used for the calculations and protections. Choice of <i>No filters</i> , or <i>average over a selected time</i> (200 or 800 milliseconds).
CPU load overview	<i>Currently</i> , <i>Average over 10 seconds</i> . <i>Average over 1 minute</i> , or <i>Average over 10 minutes</i> .
CODESYS	Option: Extended controller functionality with soft PLC. CODESYS runtime. Custom information pop-up messages and status texts. Provide better customised user experience by delivering messaging and status information from the CODESYS application. View CODESYS license type in WebConfig.
Non-essential load (NEL)	Up to 3 non-essential loads per controller. Each controller can connect to the same 3 non-essential load breakers. Alarms for over-current, under-frequency, overload, and reactive overload for each non-essential load.
Additional hardware/ software features	Power supply voltage measurement diode offset. Output configuration (function, coil state). Analogue input sensor failure (below and above range). Analogue input pre-configured curves, plus up to 20 customisable curves. Analogue output pre-configured curves, plus up to 20 customisable curves.

- NOTE** * Generator controllers only.
 ** Static synchronisation cannot be performed in non-regulating controller types where regulation is required.
 *** Supported engines only. See the [Engine interface communication manual](#) for the supported J1939 engines and manufacturers. Idle run may not be permitted or approved by certain maritime classification societies.
 **** With Power management software licence.

Display	
Easy and user-friendly interface	Easy control with customisable dashboards. Adaptive mimics. Configurable physical buttons. 7" colour touch screen that can be used in combination with physical buttons.
Fast short-cut button	Configurable shortcut feature gives the user easy access to frequently used functions.

Communication	
Plug and play	Automatic network configuration (uses static IPv6) Automatic date and time synchronisation between all controllers in the system NTP time synchronisation with NTP servers
Redundancy	Redundant Ethernet
Multi-master system	<ul style="list-style-type: none"> • Multi-master system. All vital data is broadcast to all controllers: <ul style="list-style-type: none"> ◦ Each controller performs all calculations, then acts accordingly. ◦ Power management inputs and outputs may be connected to any controller. ** ◦ Load sharing communication
Ethernet communication	<ul style="list-style-type: none"> • 3 Ethernet ports for: <ul style="list-style-type: none"> ◦ Power management • Secured protocols on Ethernet communication • Static Internet Protocol version 6 (IPv6) • Configurable Internet Protocol version 4 (IPv4) • Alarms for Unknown traffic and Data loss.
CAN bus communication	3 CAN ports for:

Communication	
	<ul style="list-style-type: none"> • J1939-based ECU communication • Communication to Digital AVR: <ul style="list-style-type: none"> ◦ DVC 350 ◦ DVC 550 ◦ Leroy Somer D550
RS-485 communication *	2 serial ports configurable as client or server
Modbus server	Supports multiple Modbus protocols: TCP/IP, RTU * Standard protocol: Modbus server, TCP/IP Supports use and creation of custom protocols. Import and export Modbus protocols. Convert data units and scaling. Configure Modbus server settings.

NOTE * For future use.
** With Power management licence.



More information

See the [Engine interface communication manual](#) for the supported J1939 engines and manufacturers.

Configuration tool - PICUS	
General features	PC software to connect to one or more controllers. Application design (Single-line diagram) tool for creation, configuration and broadcast. Updated firmware for the controller and display. Supports multiple controller languages. Backup / restore projects or configurations. Commissioning tools.
Display designer	For creation and configuration on the display: Dashboard layout and widgets. Header design and widgets.
Controller configuration	Configure controller inputs, outputs, and parameters. View status and live data. Manage backups and restores. Use offline projects to view or edit a controller configuration.
System emulation	Safely mimic the environment that the controller connects to (loads, inputs, and failure scenarios).
System supervision	Supervise and control the application.
Alarms and log events	Manage alarms. Run alarm tests. View event logs and J1939 DM2 logs (if ECU enabled).
Input / output status	See an overview for all the input and output values for the controller, extension racks, and ECU (if configured).
Trending	Record and save operational values over a period of time. Export recorded trace values to a .csv file.
Tags	Show or hide Tags for Alarm pop-up, alarms, log, parameters, and reports.
Permission control	Role and user management.
CustomLogic	User-friendly logic configuration tool, based on ladder logic and function blocks. Selectable input events and output commands per controller.

Configuration tool - PICUS

Inter-controller communication with each controller in the system. (For compatible controllers).
Modbus signals (inputs and/or outputs).

WebConfig

WebConfig

A browser-based tool to connect to the controller IP address.
View controller information.
Manage cybersecurity configuration.
If required, restart the controller or do a factory reset.

1.3 Alarms and protections

1.3.1 Alternating current (AC) protections

The controllers include the following alternating current (AC) protections, according to IEEE Std. C37.2™-2008.

The *operate time* is defined in IEC 447-05-05 (from the instant when the need for the protection arises, to when the controller output has responded). For each protection, the *operate time* is given for the minimum user-defined time delay.

All AC alarms are available on all controller types, unless noted in the alarm column.

Controller type	A-side	B-side
GENSET	Generator	Busbar
EMERGENCY *	Generator	Busbar
HYBRID	Inverter	Busbar
SHAFT generator	Generator	Busbar
SHORE connection	Shore busbar	Ship busbar
BUS TIE breaker	Busbar A	Busbar B

NOTE * With the Power management licence.

AC protections for the A-side

Protection	Alarms	IEC symbol (IEC 60617)	ANSI (IEEE C37.2)	Operate time	Based on
Over-voltage	3	U>	59	< 100 ms	The highest phase-to-phase (or phase-to-neutral) voltage
Under-voltage	3	U<	27	< 100 ms	The lowest phase-to-phase (or phase-to-neutral) voltage
Voltage unbalance (voltage asymmetry)	1	UUB>	47	< 200 ms *	The highest difference between any of the 3 phase-to-phase (or phase-to-neutral) voltage true RMS values, and the average value
Positive sequence under-voltage	1	U ₁ <	27D	< 60 ms ***	The estimated phase-to-neutral voltage phasors
Negative sequence voltage	1	U ₂ >	47	< 200 ms *	The estimated phase-to-neutral voltage phasors
Zero sequence voltage	1	U ₀	59U ₀	< 200 ms *	The estimated phase-to-neutral voltage phasors
Over-current	2	3I>	50TD	< 100 ms	The highest phase current true RMS value
Fast over-current (short circuit)	2	3I>>>	50/50TD	< 50 ms	The highest phase current true RMS value
Current unbalance (average)	1	IUB>	46	< 200 ms *	The highest difference between any of the 3 phase currents and the average value
Current unbalance (nominal)	1	IUB>	46	< 200 ms *	The highest difference between any of the 3 phase currents and the nominal value

Protection	Alarms	IEC symbol (IEC 60617)	ANSI (IEEE C37.2)	Operate time	Based on
Directional over-current	2 **	$I > \rightarrow$	67	< 100 ms	The highest phase current true RMS value, with the direction from the active power
Inverse time over-current	1	$I t >$	51	-	The highest phase current true RMS value, based on IEC 60255 part 151
Negative sequence current	1	$I_2 >$	46	< 200 ms *	The estimated current phasors
Zero sequence current	1	$I_0 >$	51I ₀	< 200 ms *	The estimated current phasors
Over-frequency	2	$f >$	81O	< 100 ms	The lowest fundamental frequency of a phase voltage
Under-frequency	2	$f <$	81U	< 100 ms	The highest fundamental frequency of a phase voltage
Overload (power export)	3	$P >$	32	< 100 ms	The active power (all phases)
Reverse power (power import)	2 *****	$P <$	32R	< 100 ms	The active power (all phases)
Overload reverse power ****	2		32R	< 100 ms	The active power (all phases)
Over-excitation (reactive power export)	2	$Q >$	40O	< 100 ms	The reactive power (all phases)
Under-excitation (reactive power import/ loss of excitation)	2	$Q <$	40U	< 100 ms	The reactive power (all phases)
Active synchroniser (including blackout close)	Not an alarm	-	25A	-	The frequency difference, the voltage difference, and the phase across the breaker

NOTE * These operate times include the minimum user-defined delay of 100 ms.
 ** The **BUS TIE breaker** controller has 4 directional-over current alarms.
 *** This operate time includes the minimum user-defined delay of 20 ms.
 **** Only for **HYBRID** controller.
 ***** The **BUS TIE breaker** controller has 3 power import alarms.

AC protections for the B-side

Protection	Alarms	IEC symbol (IEC 60617)	ANSI (IEEE C37.2)	Operate time	Based on
Over-voltage	3	$U >$	59	< 50 ms	The highest phase-to-phase (or phase-to-neutral) voltage
Under-voltage	3	$U <$	27	< 50 ms	The lowest phase-to-phase (or phase-to-neutral) voltage
Voltage unbalance (voltage asymmetry)	1	$UUB >$	47	< 200 ms *	The highest difference between any of the 3 phase-to-phase (or phase-to-neutral) voltage true RMS values, and the average value
Positive sequence under-voltage	1	$U_1 <$	27D	< 60 ms **	The estimated phase-to-neutral voltage phasors

Protection	Alarms	IEC symbol (IEC 60617)	ANSI (IEEE C37.2)	Operate time	Based on
Negative sequence voltage	1	$U_{2>}$	47	< 200 ms *	The estimated phase-to-neutral voltage phasors
Zero sequence voltage	1	U_0	$59U_0$	< 200 ms *	The estimated phase-to-neutral voltage phasors
Over-frequency	2	$f>$	810	< 50 ms	The lowest fundamental frequency of a phase voltage
Under-frequency	2	$f<$	81U	< 50 ms	The highest fundamental frequency of a phase voltage

NOTE * This operate time includes the minimum user-defined delay of 100 ms.

** This operate time includes the minimum user-defined delay of 20 ms.

Other AC protections for the A-side

Protection	Alarms	IEC symbol (IEC 60617)	ANSI (IEEE C37.2)	Operate time	Based on
Earth inverse time over-current	1 *		51G	-	The current RMS value, measured by the 4th current measurement, filtered to attenuate the third harmonic (at least 18 dB).
Neutral inverse time over-current	1 *		51N	-	The current RMS value, measured by the 4th current measurement.

NOTE * These protections each need the 4th current measurement. You can therefore only use one of these protections.

Other features

Feature	IEC symbol (IEC 60617)	ANSI (IEEE C37.2)	Operate time	Based on
Lockout relay		86	-	Protected equipment. Alarms can be configured with a Latch, which remain active until the operator resets the latch.



We would love to hear from you.

Help us improve our documentation by giving us feedback.

[Click here](#)

1.4 Applications

1.4.1 Applications

With power management, the controller can handle simple or advanced applications for a variety of marine and offshore industry projects. Applications include synchronising generators, critical power, emergency standby, and power production.

The complete system is easily monitored and controlled from PICUS through a graphical supervision page. The values that are presented in the intuitive and easy-to-use user interface include the running status, hours in operation, breaker status, condition of shore and busbars, and fuel consumption.

Example application with Load sharing

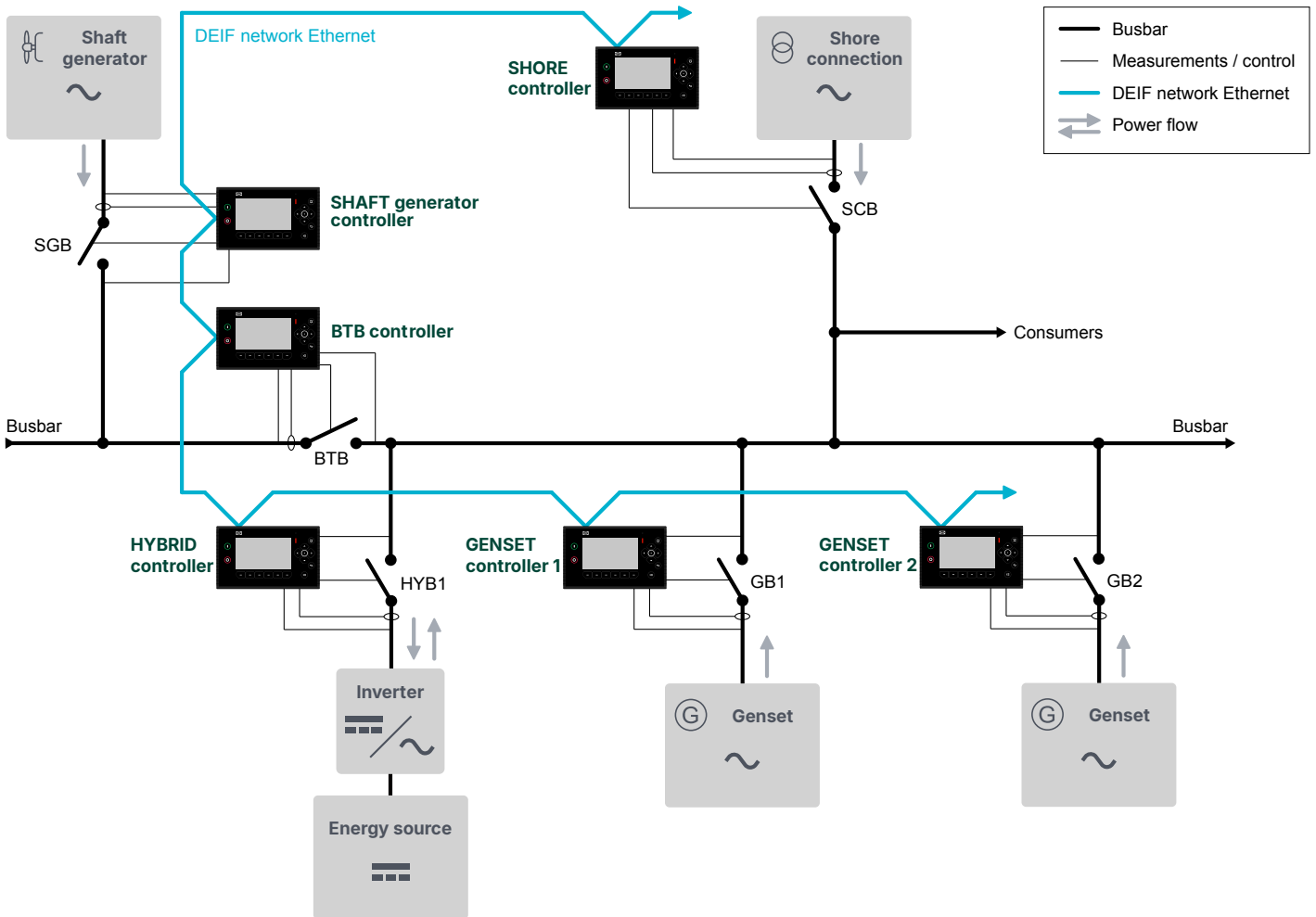

Example application with Power management

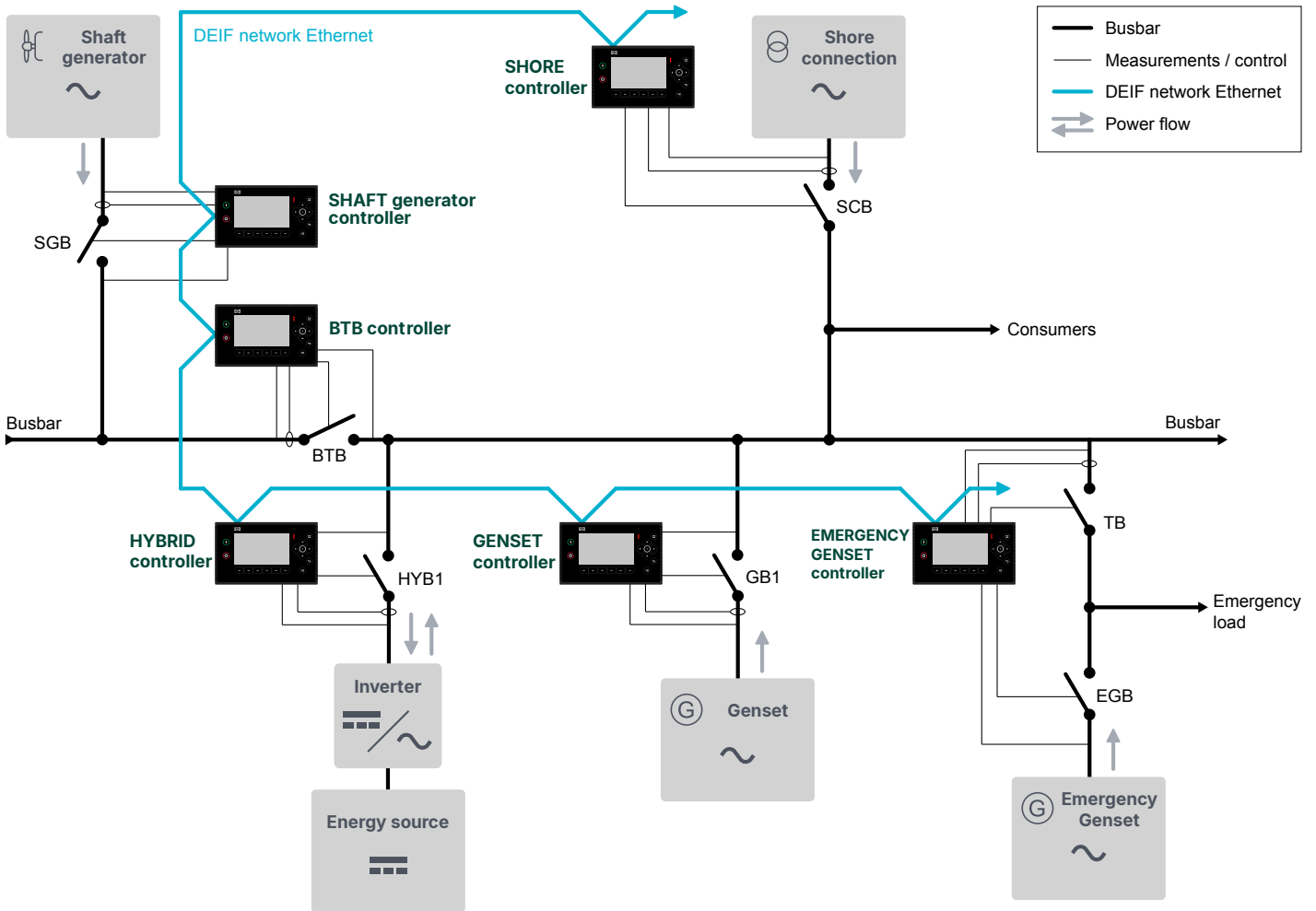

1.4.2 Extension rack functions

	Functions
General	<ul style="list-style-type: none"> Extends I/O interface <ul style="list-style-type: none"> 6 additional hardware modules in Rack7.1 3 additional hardware modules in Rack4.1

1.5 Compatible products

1.5.1 DEIF digital voltage controllers (DVC)

DVC 350 is a digital AVR designed for alternators with SHUNT, AREP or PMG excitation. The DVC 350 monitors and regulates the alternator output voltage. iE 250 can control the DVC 350 features and receive fault information directly with the CAN bus communication.



More information

See www.deif.com/products/dvc-350

DVC 550 is an advanced digital AVR designed for alternators with SHUNT, AREP or PMG excitation. The DVC 550 monitors and regulates the alternator output voltage. iE 250 can control all the DVC 550 features and receive fault information directly with the CAN bus communication.



More information

See www.deif.com/products/dvc-550

1.5.2 Additional inputs and outputs

Series 300 extension modules

You can use the Series 300 extensions racks and range of modules.



More information

See www.deif.com/products/series-300-modules/ for information about all the racks and modules.

Extension racks

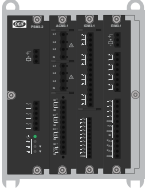

Extension rack R4.1

1 PSM3.2
3 module selection

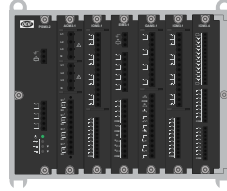

Extension rack R7.1

1 PSM3.2
6 module selection

Modules



IOM3.1 - Input/output module

4 changeover relay outputs
10 digital inputs



IOM3.2 - Input/output module

4 relay outputs
4 analogue multifunctional outputs (including 2 pulse width modulation PWM outputs)
4 digital inputs
4 analogue multifunctional inputs



IOM3.3 - Input/output module

10 analogue multifunctional inputs



IOM3.4 - Input/output module

12 digital outputs
16 digital inputs

iE 650 modules

You can use CODESYS to use modules from iE 650.



More information

See the **iE 650 PLC Data sheet** for details of these modules.

Rack6-4 (4 slots)

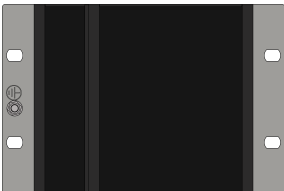

Rack6-14 (14 slots)

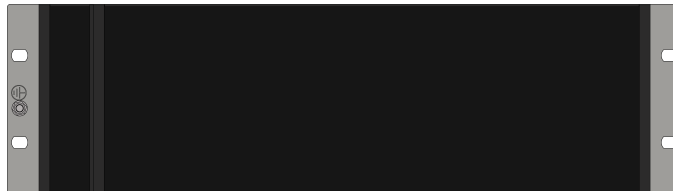

Racks with 6, 8, 10, and 12 slots are also available.

Modules



DIO6-2 - Input/output module

16 digital inputs
16 digital outputs



DIM6-1 - Input module

32 digital inputs



DOM6-1 - Output module

32 digital outputs



AIO6-2 - Input/output module

8 analogue outputs
8 analogue inputs



AOM6-2 - Output module

8 analogue inputs



AIM6-1 - Input module

16 analogue outputs
(Use AIM6-2 if only 8 analogue outputs are required)

1.5.3 Other equipment

DEIF has a wide variety of other equipment that is compatible. This includes synchroscopes, meters, transducers, current transformers, power supplies, and battery chargers.



More information
See www.deif.com

2. Technical specifications

2.1 Dimensions

2.1.1 iE 250 (7"): Front-mounted controller with MIO2.1

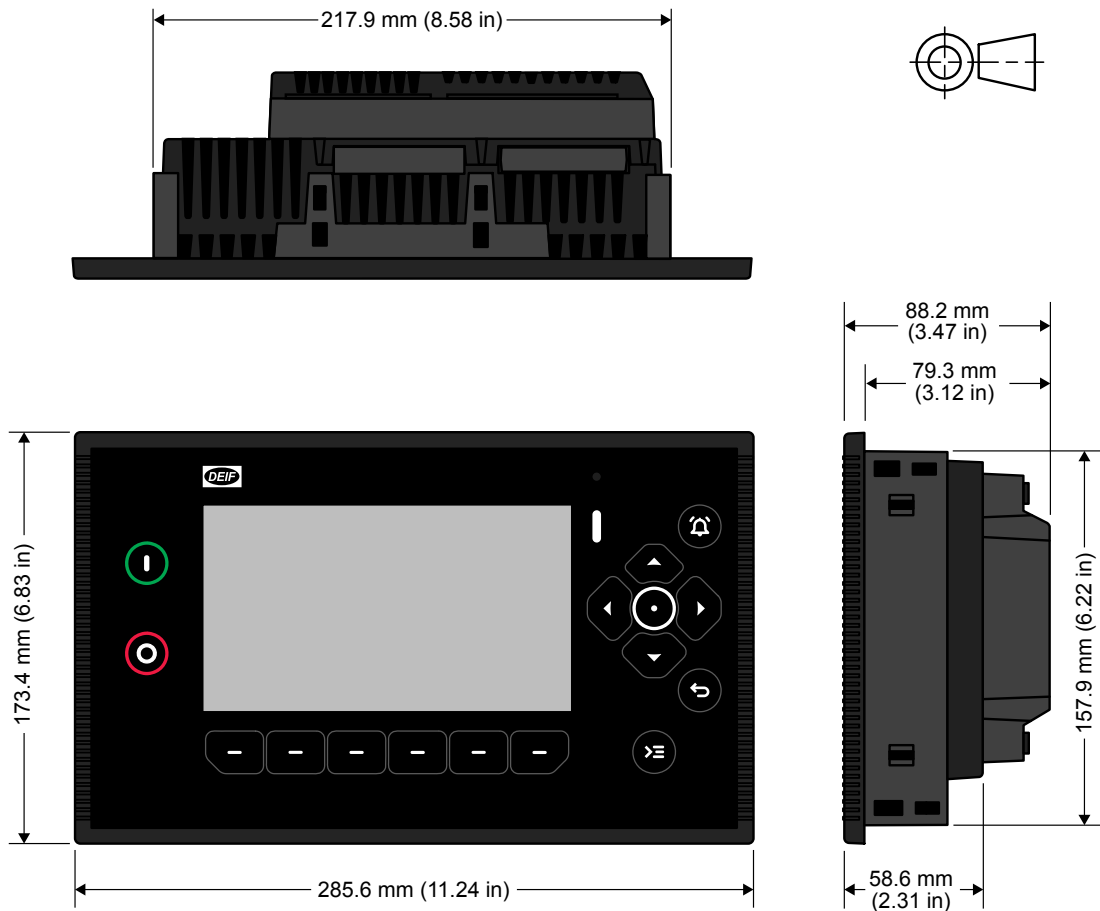

Category	Specifications
Dimensions	With MIO: L×H×D: 285.6 × 173.4 × 88.2 mm (11.24 × 6.83 × 3.47 in) (outer frame) Without MIO: L×H×D: 285.6 × 173.4 × 58.6 mm (11.24 × 6.83 × 2.30 in) (outer frame)
Panel cutout	L×H: 220 × 160 mm (8.67 × 6.30 in) Tolerance: ± 0.3 mm (0.01 in)
Weight	With MIO: ~ 1233 g (2.72 lb)

Category	Specifications
Display	7", Projected Capacitive (PCAP), Touch
Resolution	1024x600 pixels (px)
Brightness	1200 Cd/m ²

2.1.2 iE 250 (Base): Base-mounted controller with MIO2.1

The base-mounted version is shown mounted on DIN rail. It can alternatively be mounted using the mounting holes with fixing screws or bolts.

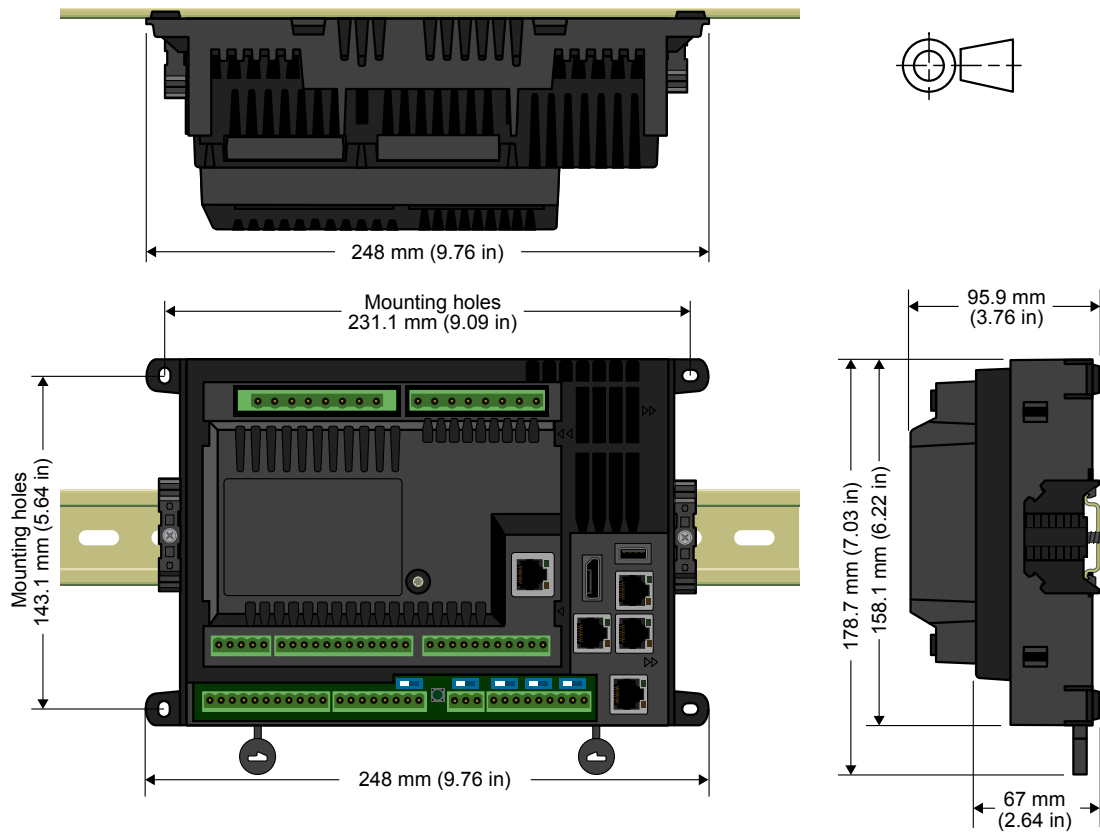

Category	Specifications
Dimensions	With MIO: L×H×D: 248 × 178.7 × 95.9 mm (9.76 × 7.03 × 3.76 in) (outer frame)
	Without MIO: L×H×D: 248 × 178.7 × 67 mm (9.76 × 7.03 × 2.64 in) (outer frame)
Mounting holes	L×H: 231.1 × 143.1 mm (9.09 × 5.64 in)
Weight	With MIO: ~ 942 g (2.07 lb)

2.1.3 iE 7 display

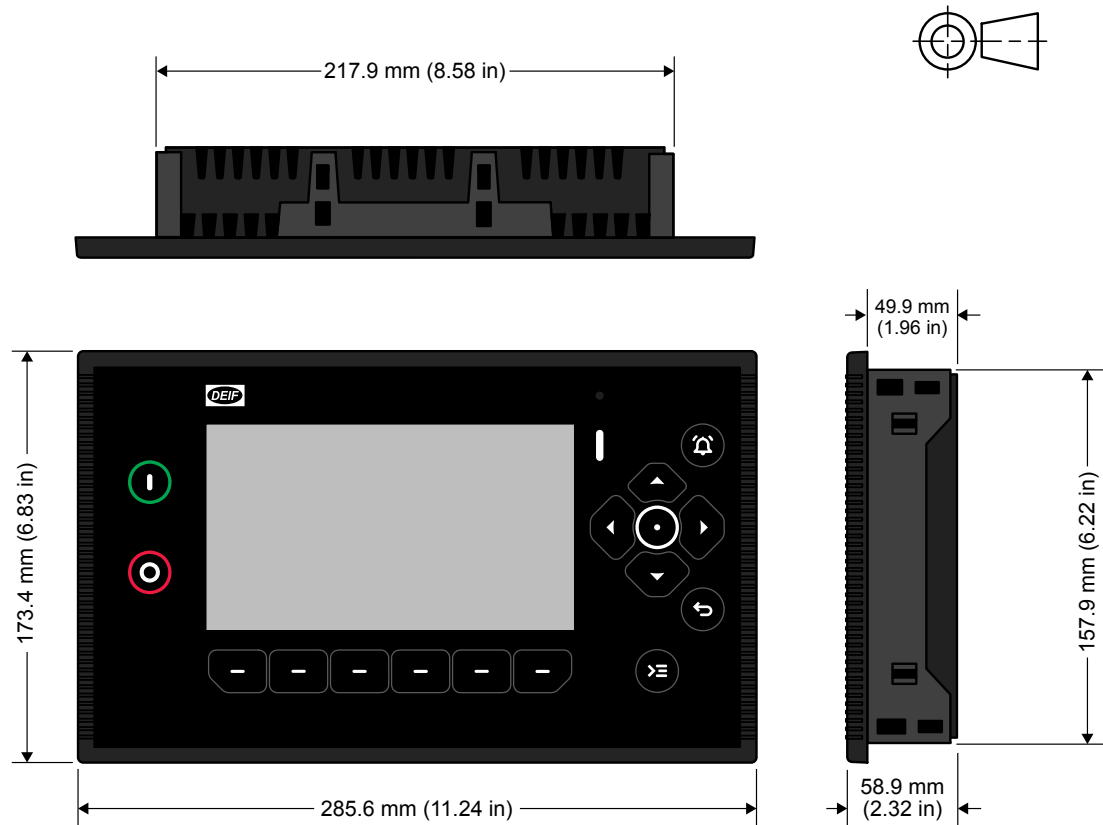

Category	Specifications
Dimensions	L×H×D: 285.6 × 173.4 × 58.9 mm (11.24 × 6.83 × 2.32 in) (outer frame)
Panel cutout	L×H: 220 × 160 mm (8.67 × 6.30 in)
Weight	840 g (1.9 lb)

Category	Specifications
Display	7", Projected Capacitive (PCAP), Touch
Resolution	1024x600 pixels (px)
Brightness	1200 Cd/m ²
Processor	1.6 GHz quad-core industrial grade ARMv8 64 bit CPU with ECC protected cache

2.1.4 Plug-in module for 8 Digital bi-directional channels (PIM-8DIO)

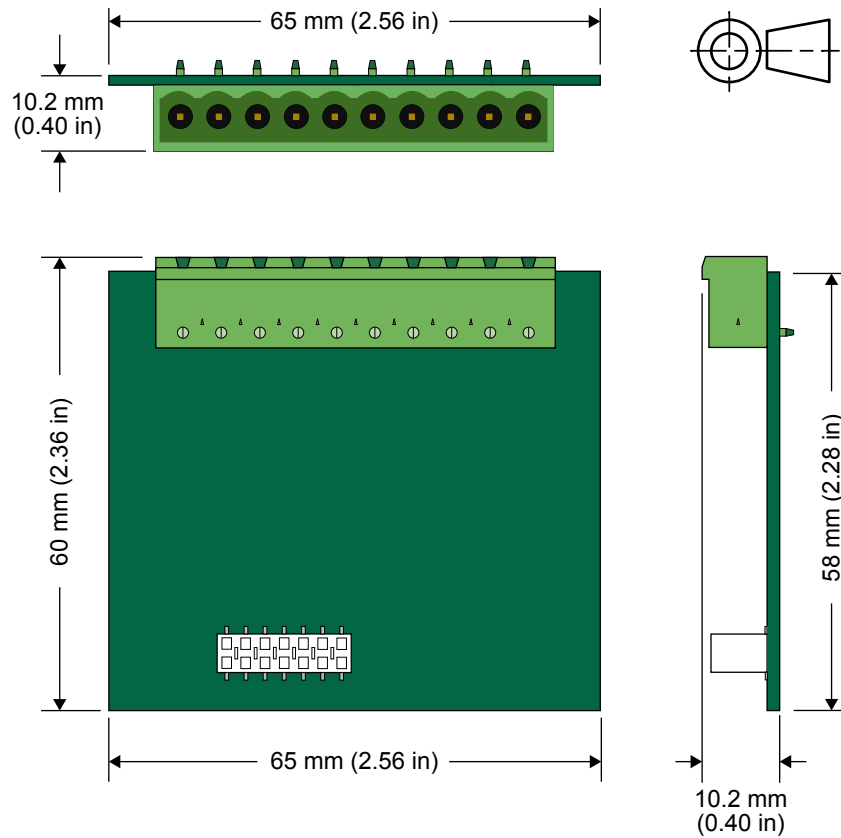

Category	Specifications
Dimensions	L×H×D: 65 × 60 × 10.2 mm (2.56 × 2.36 × 0.40 in) (outer frame)
Weight	24 g (0.05 lb)

2.1.5 Plug-in module for 4 Analogue bi-directional channels (PIM-4AIO)

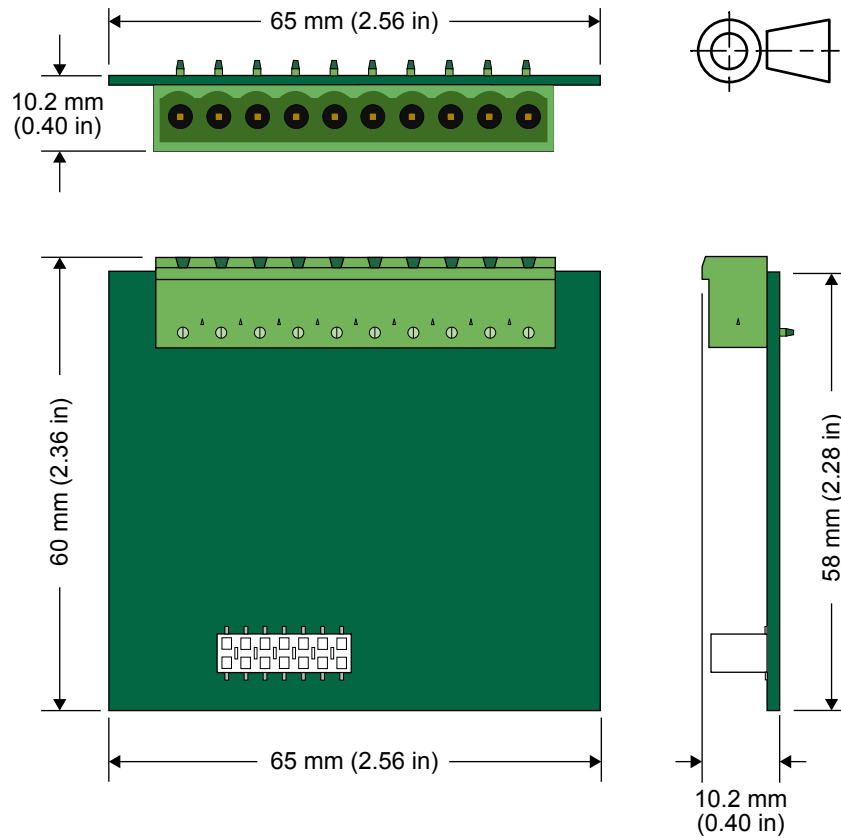

Category	Specifications
Dimensions	L×H×D: 65 × 60 × 10.2 mm (2.56 × 2.36 × 0.40 in) (outer frame)
Weight	24 g (0.05 lb)

2.2 Mechanical specifications

2.2.1 iE 250 (7"): Front-mounted controller with MIO2.1

Mechanical specifications	
Vibration	<p>Response:</p> <ul style="list-style-type: none"> 10 to 58.1 Hz, 0.15 mmpp 58.1 to 150 Hz, 1 g. To IEC 60255-21-1 (Class 2) <p>Endurance:</p> <ul style="list-style-type: none"> 10 to 150 Hz, 2 g. To IEC 60255-21-1 (Class 2) <p>Seismic vibration:</p> <ul style="list-style-type: none"> 3 to 8.15 Hz, 15 mmpp 8.15 to 35 Hz, 2 g. To IEC 60255-21-3 (Class 2)
Shock	<p>10 g, 11 ms, half sine. To IEC 60255-21-2 Response (Class 2)</p> <p>30 g, 11 ms, half sine. To IEC 60255-21-2 Withstand (Class 2)</p> <p>50 g, 11 ms, half sine. To IEC 60068-2-27, test Ea</p> <p>Tested with three impacts in each direction in three axes (total of 18 impacts per test)</p>
Bump	<p>20 g, 16 ms, half sine IEC 60255-21-2 (Class 2)</p> <p>Tested with 1000 impacts in each direction on three axes (total of 6000 impacts per test)</p>
Controller galvanic separation	<p>Supply and DIO 1 to 8: 550 V, 50 Hz, 1 minute</p> <p>AIO 1 to 4: 550 V, 50 Hz, 1 minute</p> <p>COM 1 (RS-485): 550 V, 50 Hz, 1 minute</p> <p>COM 2 (RS-485): 550 V, 50 Hz, 1 minute</p> <p>CAN A: 550 V, 50 Hz, 1 minute</p> <p>CAN B: 550 V, 50 Hz, 1 minute</p> <p>CAN C: 550 V, 50 Hz, 1 minute</p> <p>Ethernet port 1: 550 V, 50 Hz, 1 minute</p> <p>Ethernet port 2: 550 V, 50 Hz, 1 minute</p> <p>Ethernet port 3: 550 V, 50 Hz, 1 minute</p> <p>Ethernet ETH0 / Ethernet 0 : 550 V, 50 Hz, 1 minute</p>
Controller ports without galvanic separation	<p>Display port, USB port</p>
MIO2.1 galvanic separation	<p>GOV: 550 V, 50 Hz, 1 minute</p> <p>AVR: 3000 V, 50 Hz, 1 minute</p> <p>AC current via internal transformers (I4, I1, I2, I3): 2210 V, 50 Hz, 1 minute</p> <p>AC voltage A-side (N, L1, L2, L3): 3310 V, 50 Hz, 1 minute</p> <p>AC voltage B-side (N, L1, L2, L3): 3310 V, 50 Hz, 1 minute</p> <p>EtherCAT port: 550 V, 50 Hz, 1 minute</p>
MIO2.1 terminals without galvanic separation	<p>D+ and DIO 9 to 16, DI 1 to 8 and tacho</p>
Safety	<p>Installation CAT. III 600 V</p> <p>Pollution degree 2</p> <p>IEC 60255-27</p>
Flammability	<p>All plastic parts are self-extinguishing to UL94-V0</p>
EMC	<p>IEC 60255-26</p>

NOTE g = gravitational force (g-force).

2.2.2 iE 250 (Base): Base-mounted controller with MIO2.1

Mechanical specifications	
Vibration	<p>Response:</p> <ul style="list-style-type: none"> 10 to 58.1 Hz, 0.15 mmpp 58.1 to 150 Hz, 1 g. To IEC 60255-21-1 (Class 2) <p>Endurance:</p> <ul style="list-style-type: none"> 10 to 150 Hz, 2 g. To IEC 60255-21-1 (Class 2) <p>Seismic vibration:</p> <ul style="list-style-type: none"> 3 to 8.15 Hz, 15 mmpp 8.15 to 35 Hz, 2 g. To IEC 60255-21-3 (Class 2)
Shock	<p>10 g, 11 ms, half sine. To IEC 60255-21-2 Response (Class 2) *</p> <p>30 g, 11 ms, half sine. To IEC 60255-21-2 Withstand (Class 2)</p> <p>50 g, 11 ms, half sine. To IEC 60068-2-27, test Ea</p> <p>Tested with three impacts in each direction in three axes (total of 18 impacts per test)</p>
Bump	<p>20 g, 16 ms, half sine IEC 60255-21-2 (Class 2) *</p> <p>Tested with 1000 impacts in each direction on three axes (total of 6000 impacts per test)</p>
Controller galvanic separation	<p>Supply and DIO 1 to 8: 550 V, 50 Hz, 1 minute</p> <p>AIO 1 to 4: 550 V, 50 Hz, 1 minute</p> <p>COM 1 (RS-485): 550 V, 50 Hz, 1 minute</p> <p>COM 2 (RS-485): 550 V, 50 Hz, 1 minute</p> <p>CAN A: 550 V, 50 Hz, 1 minute</p> <p>CAN B: 550 V, 50 Hz, 1 minute</p> <p>CAN C: 550 V, 50 Hz, 1 minute</p> <p>Ethernet port 1: 550 V, 50 Hz, 1 minute</p> <p>Ethernet port 2: 550 V, 50 Hz, 1 minute</p> <p>Ethernet port 3: 550 V, 50 Hz, 1 minute</p> <p>Ethernet ETH0 / Ethernet 0 : 550 V, 50 Hz, 1 minute</p>
Controller ports without galvanic separation	<p>Display port, USB port</p>
MIO2.1 galvanic separation	<p>GOV: 550 V, 50 Hz, 1 minute</p> <p>AVR: 3000 V, 50 Hz, 1 minute</p> <p>AC current via internal transformers (I4, I1, I2, I3): 2210 V, 50 Hz, 1 minute</p> <p>AC voltage A-side (N, L1, L2, L3): 3310 V, 50 Hz, 1 minute</p> <p>AC voltage B-side (N, L1, L2, L3): 3310 V, 50 Hz, 1 minute</p> <p>EtherCAT port: 550 V, 50 Hz, 1 minute</p>
MIO2.1 terminals without galvanic separation	<p>D+ and DIO 9 to 16, DI 1 to 8 and tacho</p>
Safety	<p>Installation CAT. III 600 V</p> <p>Pollution degree 2</p> <p>IEC 60255-27</p>
Flammability	<p>All plastic parts are self-extinguishing to UL94-V0</p>
EMC	<p>IEC 60255-26</p>

NOTE * With DIN rail clamp end-stop mounted tight to the unit. See [DIN rail clamp](#) for the type of DIN clamp required.
g = gravitational force (g-force).

2.2.3 iE 7 display

Mechanical specifications	
Vibration	<p>Response:</p> <ul style="list-style-type: none"> • 10 to 58.1 Hz, 0.15 mmpp • 58.1 to 150 Hz, 1 g. To IEC 60255-21-1 (Class 2) <p>Endurance:</p> <ul style="list-style-type: none"> • 10 to 150 Hz, 2 g. To IEC 60255-21-1 (Class 2) <p>Seismic vibration:</p> <ul style="list-style-type: none"> • 3 to 8.15 Hz, 15 mmpp • 8.15 to 35 Hz, 2 g. To IEC 60255-21-3 (Class 2)
Shock	<p>10 g, 11 ms, half sine. To IEC 60255-21-2 Response (Class 2)</p> <p>30 g, 11 ms, half sine. To IEC 60255-21-2 Withstand (Class 2)</p> <p>50 g, 11 ms, half sine. To IEC 60068-2-27, test Ea</p> <p>Tested with three impacts in each direction in three axes (total of 18 impacts per test)</p>
Bump	<p>20 g, 16 ms, half sine IEC 60255-21-2 (Class 2)</p> <p>Tested with 1000 impacts in each direction on three axes (total of 6000 impacts per test)</p>
Controller ports without galvanic separation	DisplayPort, USB ports
Safety	<p>Installation CAT. III 600 V</p> <p>Pollution degree 2</p> <p>IEC 60255-27</p>
Flammability	All plastic parts are self-extinguishing to UL94-V0
EMC	IEC 60255-26

NOTE g = gravitational force (g-force).

2.3 Environmental specifications

2.3.1 iE 250 (7"): Front-mounted controller with MIO2.1

Environmental specifications	
Operating temperature	-30 to 70 °C (-22 to 158 °F)
Storage temperature	-30 to 80 °C (-22 to 176 °F)
Change of temperature	70 to -30 °C, 1 °C / minute, 5 cycles. To IEC 60255-1
Operating altitude	0 to 4000 m above sea level 2001 to 4000 m: Maximum 480 V AC
Operating humidity	Damp heat cyclic, Condensing. <ul style="list-style-type: none"> Low temperature: 25°C / 97% Relative humidity (RH), high temperature: 55°C / 93% Relative humidity (RH), for 144 hours. To EN IEC 60255-1. Damp heat steady state, Non-Condensing. <ul style="list-style-type: none"> 40°C / 93% Relative humidity (RH), for 240 hours. To EN IEC 60255-1.
Protection degree	EN IEC 60529 <ul style="list-style-type: none"> IP65 (front of module when installed into the control panel with the supplied sealing gasket) IP20 on terminal side

2.3.2 iE 250 (Base): Base-mounted controller with MIO2.1

Environmental specifications	
Operating temperature	-30 to 70 °C (-22 to 158 °F)
Storage temperature	-30 to 80 °C (-22 to 176 °F)
Change of temperature	70 to -30 °C, 1 °C / minute, 5 cycles. To IEC 60255-1
Operating altitude	0 to 4000 m above sea level 2001 to 4000 m: Maximum 480 V AC
Operating humidity	Damp heat cyclic, Condensing. Low temperature: 25°C / 97%RH, high temperature: 55°C / 93%RH, for 144 hours. To EN /IEC 60255-1. Damp heat steady state, Non-Condensing. 40°C / 93%RH, for 240 hours. To EN /IEC 60255-1.
Protection degree	EN IEC 60529 <ul style="list-style-type: none"> IP20 on terminal side

2.3.3 iE 7 display

Environmental specifications	
Operating temperature	-30 to 70 °C (-22 to 158 °F)
Storage temperature	-30 to 80 °C (-22 to 176 °F)
Change of temperature	70 to -30 °C, 1 °C / minute, 5 cycles. To IEC 60255-1
Operating altitude	0 to 4000 m above sea level 2001 to 4000 m: Maximum 480 V AC
Operating humidity	Damp heat cyclic, 20/55 °C at 97 % relative humidity, 144 hours. To IEC 60255-1

Environmental specifications

	Damp heat steady state, 40 °C at 93 % relative humidity, 240 hours. To IEC 60255-1
Protection degree	EN IEC 60529 <ul style="list-style-type: none">• IP65 (front of module when installed into the control panel with the supplied sealing gasket)• IP20 on terminal side

2.4 Controller

2.4.1 Terminal connections

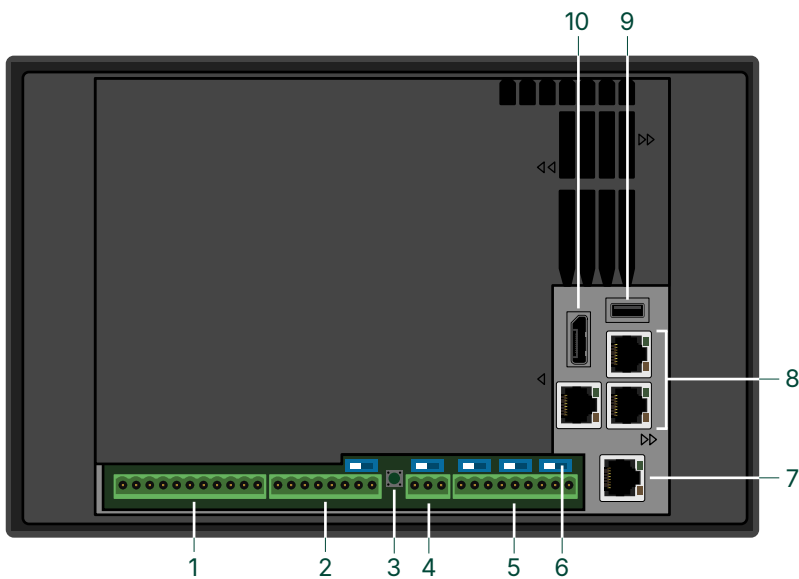

No.	Function	Notes
1	Power supply Digital bi-directional channels *	1 Power supply (DC+/-) 8 Bi-directional digital channels * DC(+) for DIO 4 to 8
2	COM 1 ** Analogue bi-directional channels	1 RS-485 ** 4 Bi-directional analogue channels
3	Push-button	
4	COM 2 **	1 RS-485 **
5	CAN	3 CAN connections
6	Built-in end resistors	5 switches to enable the end resistors 120 Ω (Ohm) for CAN or Serial termination
7	ETH0 / Ethernet 0	1 Ethernet connection bridged to switch
8	Ethernet	3 Ethernet switch connections
9	USB	USB host (type A)
10	DisplayPort	For use with the base-mounted version. External third-party non-DEIF displays should be configured to Input mode instead of Automatic detection.

NOTE * Breaker functions must be assigned to MIO channels.

** Future use. Can be used with CODESYS if license is installed.

2.4.2 Electrical specifications

Power supply	
Input voltage	Nominal voltage: 12 V DC or 24 V DC (Operation range: 6.5 to 36 V DC) Power up at 8 V Operation down to 6.5 V at 15 W
Start current	Power supply current limiter

Power supply

	<ul style="list-style-type: none">• 24 V: 4 A minimum• 12 V: 8 A minimum Battery: No limit
Voltage withstand	Reverse polarity
Power supply drop-out immunity	0 V DC for 50 ms (coming from more than 6.5 V DC) at 15 W
Power supply load dump protection	Load dump protected according to ISO16750-2 test A
Power consumption	15 W typical

Analogue bi-directional channels

4 individual channels (isolated group) with configurable function.
Configurable as input or output channels.
Galvanic separation to CPU
All channels in one electric group

Input channels

Digital input	0 to 24 V DC with common threshold 4 V
Resistor measurement	Range: 0 to 1 M Ω Accuracy 0 to 80 Ω : $\pm 1\%$ $\pm 0.5\ \Omega$ 80 Ω to 10 k Ω : $\pm 0.4\%$ 10 to 20 k Ω : $\pm 0.5\%$ 20 to 200 k Ω : $\pm 1.5\%$ 200 to 1000 k Ω : $\pm 12\%$
Voltage input	0 to 10 V DC (16-bit sigma delta) Accuracy: 0.5 % of full scale over the operating temperature range. Input impedance: 200 k Ω .
Current input	0 to 20 mA (16-bit sigma delta) Accuracy: 0.6 % of full scale over the operating temperature range.
Output channels	
Voltage output	0 to 10 V DC (13-bit resolution) Accuracy: 0.5 % of full scale over the operating temperature range.
Current output	0 to 20 mA (13-bit resolution) Accuracy: 0.6 % of full scale over the operating temperature range. Maximum 2 channels can be selected as current output (internal power limitation)

Digital bi-directional channels

8 individual channels (one galvanic isolated group) with configurable function.
Configurable as input or output channels.

Modes:

- Disabled
- Digital input (sourcing) (negative switching)
- Digital output (sourcing)

Digital input channels	0 to 24 V DC Current source (contact cleaning): Initial 10 mA, continuous 2 mA
Digital output channels	Output voltage: 12 to 24 V DC Digital output switch output voltage is dependant on DC+ <ul style="list-style-type: none">• DIO channels 1 to 4 use terminal 1.• DIO channels 5 to 8 use terminal 7.

Digital bi-directional channels	
	2 A DC inrush and 0.5 A continuous (maximum 2 A for continuous for all channels)

Real-Time Clock (RTC) battery	
Battery type	CR2430 3V battery, rated for operation at -40 to 85°C (-40 to 185 °F). This is not a standard CR2430 battery.

2.4.3 Communication specifications

Communication specifications	
CAN A	Engine, DVC, or power management
CAN B	Data connection 2-wire and common (isolated)
CAN C	Switch 120 Ω (ohm) termination resistors
COM 1 (RS-485) *	Data connection 2-wire and common (isolated) Switch 120 Ω (ohm) termination resistors
COM 2 (RS-485) *	Data connection 2-wire and common (isolated) Switch 120 Ω (ohm) termination resistors
USB	USB host (type A)
3 Ethernet (SWP1, SWP2, SWP3)	Switch for Ethernet connections RJ45 Use an Ethernet cable that meets or exceeds the SF/UTP CAT5e specifications
ETH0 / Ethernet 0	Ethernet bridged to the switch RJ45 Use an Ethernet cable that meets or exceeds the SF/UTP CAT5e specifications
DisplayPort	For base-mounted versions only Connection to a display

NOTE * For future use. Can be used with CODESYS if license is installed.

2.5 iE 7 display

2.5.1 Terminal connections

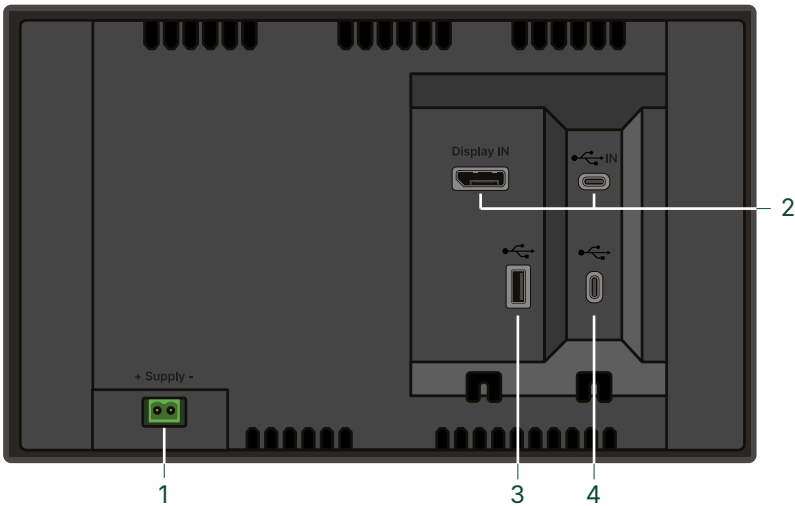

No.	Function	Notes
1	Power supply	1 Power supply (DC+/-)
2	DisplayPort USB IN	Connection to base-mounted controller. USB 2.0 host (type C)
3	USB	USB 2.0 host (type A)
4	USB	USB 2.0 host (type C)

2.5.2 Electrical specifications

Power supply	
Input voltage	Nominal voltage: 12 V DC or 24 V DC (Operation range: 6.5 to 36 V DC) Power up at 8 V Operation down to 6.5 V at 15 W Operation down to 6.9 V at 28 W
Voltage withstand	Reverse polarity
Power supply drop-out immunity	0 V DC for 50 ms (coming from more than 6.5 V DC) at 15 W
Power supply load dump protection	Load dump protected according to ISO16750-2 test A
Power consumption	15 W typical 28 W maximum

Battery voltage measurement	
Accuracy	± 0.8 V within 8 to 32 V DC, ± 0.5 V within 8 to 32 V DC @ 20 °C

2.5.3 Communication specifications

Communication specifications	
DisplayPort *	Connection to base-mounted controller.
USB IN *	Connection to base-mounted controller. USB 2.0 (type C).

Communication specifications

USB hub Type A	For future use.
----------------	-----------------

USB hub Type C	For future use.
----------------	-----------------

NOTE * Both DisplayPort and USB IN are required for communication and control to the controller.

2.6 Measurement Input Output module (MIO2.1)

2.6.1 About

The Measurement Input and Output module (MIO2.1) is an add-on module for the iE 250. It features 8 bi-directional digital terminals, allowing smart flexibility where you can use them for what you need.

AC measurements

The module measures the voltage and current on one side of a breaker, and the voltage on the other side. The hardware module responds when the measurements exceed the AC alarm parameters.

The module provides robust frequency detection in environments with electrical noise. It allows extended measurement bandwidth up to 40 times the nominal frequency. It includes a configurable 4th current measurement.

Additional features

- Analogue outputs for GOV and AVR.
- 8 Digital input channels.
- 8 Digital bi-directional channels.
- Analogue Tacho (MPU/N/NPN/PNP) input.

2.6.2 Terminal connections

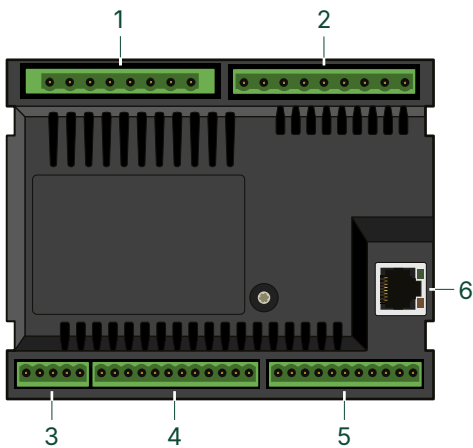

No.	Function	Notes
1	AC current	A-side: L1 (S1,S2) L2 (S1,S2) L3 (S1,S2) A-side or B-side: L4 (S1,S2)
2	AC voltage	A-side: N, L1, L2, L3 B-side: N, L1, L2, L3
3	Analogue outputs (GOV/AVR)	AVR (+/-) GOV (+/-)
4	D+ and Digital bi-directional channels	D+ E-stop power cut-off 8 Bi-directional configurable channels
5	Digital input channels and Tacho	8 Digital inputs

No.	Function	Notes
		Tacho
6	EtherCAT	Connection to extension racks

2.6.3 Electrical specifications

All AC measurement specifications are within the reference conditions, unless otherwise stated.

Voltage measurements	
Nominal value (Un)	100 to 690 V AC, phase-to-phase
Reference range	30 to 931.5 V AC
Measurement range	5.0 to 931.5 V AC, phase-to-phase; Truncation: 2 V AC
Accuracy	5.0 to 931.5 V AC: $\pm 0.5\%$ or ± 0.5 V AC (whichever is greater) (Class 5.0)
UL/cUL Listed	600 V AC phase-phase
Consumption	Maximum 0.25 VA/phase
Voltage withstand	Un + 35 % continuously Un + 45 % for 10 seconds

Current measurements	
Nominal value (IN)	1 or 5 A AC from current transformer
Measurement range	0.005 to 20.0 A AC, Truncation: 4 mA AC
Accuracy	0.005 to 20.0 A AC: $\pm 0.5\%$ or ± 5 mA AC (whichever is greater) (Class 0.005)
UL/cUL Listed	From listed or R/C (XODW2.8) current transformers 1 or 5 A AC
Consumption	Maximum 0.3 VA/phase
Current withstand	10 A AC continuous 20 A AC for 1 minute 75 A AC for 10 seconds 250 A AC for 1 second

Frequency measurements	
Nominal value	50 Hz or 60 Hz
Reference range	45 to 66 Hz
Measurement range	10 to 75 Hz
System frequencies	Accuracy: 10 to 75 Hz ± 5 mHz, within the temperature operating range.
Phase frequencies	Accuracy: 10 to 75 Hz ± 10 mHz, within the temperature operating range.

Phase angle (voltage) measurement	
Measurement range	-179.9 to 180°
Accuracy	-179.9 to 180°: 0.2°, within the temperature operating range

Power measurement	
Accuracy	$\pm 0.5\%$ of measured value or $\pm 0.5\%$ of $U_n \cdot I_n$, whichever is greater, within the current measurement range (Class 0.5)

AC Measurement temperature and accuracy

AC Measurement reference range	-20 to 55 °C (-4 to 131 °F)
Temperature-dependent accuracy outside the reference range	Voltage: Additional: ±0.05 %, or ±0.05 V AC per 10 °C (18 °F) (whichever is greater) Current: Additional: ±0.05 %, or ±0.5 mA AC per 10 °C (18 °F) (whichever is greater) Power: Additional: ±0.05 %, or ±0.05 % of $U_n \cdot I_N$ per 10 °C (18 °F) (whichever is greater)

Digital input channels

8 individual input channels with configurable function.

- Digital input (sourcing) (negative switching)

Current or negative source (contact cleaning): Initial 10 mA, continuous 2 mA.

D+

Excitation current	210 mA, 12 V 105 mA, 24 V
Charging fail threshold	6 V
E-stop power cut-off	An e-stop on terminal 46 cuts the power to the D+ terminal.

Tacho

Voltage input range	± 1 to 70 V _p
W	8 to 36 V
Frequency input range	10 to 10 kHz
Frequency measurement tolerance	1 % of reading
Wire break detection	Yes

Digital bi-directional channels

8 bi-directional digital channels with configurable function.

All channels in one electric group.

Configurable as input or output channels.

Modes:

- Disabled
- Digital input (sourcing) (negative switching)
- Digital output (sourcing)

Digital input	0 to 24 V DC Current source (contact cleaning): Initial 10 mA, continuous 2 mA
Digital output	Supply voltage: 12 to 24 V (operating range 6.5 to 28 V DC) <ul style="list-style-type: none">• DIO channels 9 to 12 supply on terminal 46 DC (+) (optional: E-stop power cut-off)• DIO channels 13 to 16 supply on terminal 52 Output current: 2 A DC inrush and 0.5 A continuous (maximum 2 A continuous for all channels)

Analogue outputs for GOV or AVR

Output types for GOV or AVR	DC output or PWM
Minimum load resistance	500 Ω (Ohm) or 20 mA

Governor (GOV)	
DC voltage output range	-10.5 to 10.5 V DC
PWM output voltage	Default 6 V, configurable in platform level via EtherCAT in the range 1 to 10.5 V Application level fixed to platform configuration
PWM frequency range	1 to 2500 Hz \pm 25 Hz
PWM duty cycle resolution	12 bits (4096 steps)
Accuracy	Accuracy: \pm 1 % of setting

Automatic voltage regulator (AVR)	
DC voltage output range	-10.5 to 10.5 V DC
PWM output voltage	Default 6 V, configurable in platform level via EtherCAT in the range 1 to 10.5 V Application level fixed to platform configuration
PWM frequency range	1 to 2500 Hz \pm 25 Hz
PWM duty cycle resolution	12 bits (4096 steps)
Accuracy	Accuracy: \pm 1 % of setting

2.6.4 Communication specifications

EtherCAT	
EtherCAT communication	RJ45 Use an Ethernet cable that meets or exceeds the SF/UTP CAT5e specifications

2.7 Plug-in module for 8 Digital bi-directional channels (PIM-8DIO)

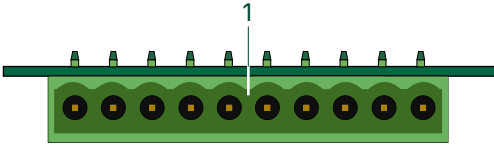

No.	Function	Notes
1	Digital bi-directional channels	COM+ 8 Bi-directional digital channels Ground

Electrical specifications

Digital bi-directional channels

8 bi-directional digital channels with configurable function.
All channels in one electric group.
Configurable as input or output channels.

Modes:

- Disabled
- Digital input (sourcing) (negative switching)
- Digital output (sourcing)

Digital input	0 to 24 V DC Current source (contact cleaning): Initial 10 mA, continuous 2 mA
Digital output	Supply voltage: 12 to 24 V (operating range 6.5 to 28 V DC) Output current: Up to 0.5 A (maximum 1 A for all 4 channels) 2 A DC inrush and 0.5 A continuous (maximum 2 A for continuous for all channels)

2.8 Plug-in module for 4 Analogue bi-directional channels (PIM-4AIO)

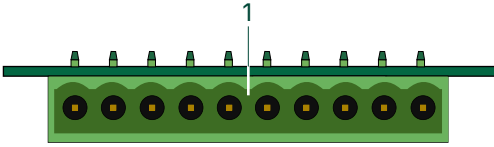

No.	Function	Notes
1	Analogue bi-directional channels	4 Analogue bi-directional channels Ground

Electrical specifications

Analogue bi-directional channels	
4 individual channels (isolated group) with configurable function. Configurable as input or output channels. Galvanic separation to CPU All channels in one electric group	
Input channels	
Digital input	0 to 24 V DC with common threshold 4 V
Resistor measurement	Range: 0 to 1 M Ω Accuracy 0 to 80 Ω : $\pm 1\%$ $\pm 0.5\ \Omega$ 80 to 200 Ω : $\pm 0.4\%$ 200 Ω to 10 k Ω : $\pm 0.4\%$ 10 to 20 k Ω : $\pm 0.5\%$ 20 to 200 k Ω : $\pm 1.5\%$ 200 to 1000 k Ω : $\pm 12\%$
Voltage input	0 to 10 V DC (16-bit sigma delta) Accuracy: 0.5 % of full scale over the operating temperature range. Input impedance: 200 k Ω
Current input	0 to 20 mA (16-bit sigma delta) Accuracy: 0.6 % of full scale over the operating temperature range.
Output channels	
Voltage output	0 to 10 V DC (13-bit resolution) Accuracy: 0.5 % of full scale over the operating temperature range.
Current output	0 to 20 mA (13-bit resolution) Accuracy: 0.6 % of full scale over the operating temperature range. Maximum 2 channels can be selected as current output (internal power limitation)

2.9 Accessories

2.9.1 DIN rail clamps

These are supplied with the base-mounted version.

Category	Specification
DIN rail	35
Type	E/NS 35 N BK - End bracket

2.9.2 USB type A to C cable

The USB cable is necessary for control between the display and base-mounted controller.

This is supplied with the iE 7 display.

Category	Specification
Cable type	USB type A to type C cable.
USB	USB 2.0
Length	3.0 m (9.85 ft)

2.9.3 DisplayPort cable

The DisplayPort cable is necessary for visual HMI between the display and base-mounted controller.

This is supplied with the iE 7 display.

Category	Specification
Cable type	VESA DisplayPort compliant cable.
Length	3.0 m (9.85 ft)

2.9.4 Ethernet cable

The Ethernet cable from DEIF meets the technical specifications below.

Category	Specification
Cable type	Shielded patch cable SF/UTP CAT5e
Temperature	Fixed installation: -40 to 80 °C (-40 to 176 °F) Flexible installation: -20 to 80 °C (-4 to 176 °F)
Minimum bending radius (recommended)	Fixed installation: 25 mm (1 in) Flexible installation: 50 mm (2 in)
Length	2 m (6.6 ft)
Weight	~110 g (4 oz)

2.10 Approvals

Standards
CE
UKCA
UL/cUL Listed to - UL/ULC6200:2019 1.ed. Controllers for Use in Power Production

Marine certificates	Cybersecurity IACS UR E27
ABS	Yes
BV	Yes
DNV	Yes
LR	Yes



More information

See Approvals/certifications for the most recent certificates www.deif.com/documentation/ie-250-marine/.

2.11 Cybersecurity

Category	Specification
Cybersecurity	Certified to IACS UR E27 *

NOTE * Connections to untrusted networks may require additional equipment or security counter-measures not included in the product.

3. Legal information

3.1 Disclaimer and copyright

Open source software

This product contains open source software licensed under, for example, the GNU General Public License (GNU GPL) and GNU Lesser General Public License (GNU LGPL). The source code for this software can be obtained by contacting DEIF at support@deif.com. DEIF reserves the right to charge for the cost of the service.

General warranty

The warranty period for the purchased product is defined in the contract and order acknowledgement. In general, DEIF's Terms and Conditions of Sale and Delivery apply.

The product continuously monitors the operating temperature and stores this information in a log file on the device. DEIF uses this information for service purpose and to validate if issues with the product are covered by the warranty.

The software packages supplied are believed to be of the highest quality. Due to the nature of the software development process, it is possible that there are hidden defects in the software which may affect its use, or the operation of any software or device developed with this software package.

DEIF does not undertake responsibility for determining whether this package is suitable for the application, nor for ensuring the correct operation of the application software and hardware.

The warranty does not cover product wear parts, such as:

- Internal flash disc
- If applicable, SD card (purchased separately)
- Replaceable coil-cell battery, used for the real-time clock (available as a spare part)

Trademarks

DEIF and the DEIF logo are trademarks of DEIF A/S.

BELDEN is a trademark of BELDEN INC.

Bonjour[®] is a registered trademark of Apple Inc. in the United States and other countries.

Adobe[®], *Acrobat*[®], and *Reader*[®] are either registered trademarks or trademarks of Adobe Systems Incorporated in the United States and/or other countries.

CANopen[®] is a registered community trademark of CAN in Automation e.V. (CiA).

SAE J1939[®] is a registered trademark of SAE International[®].

CODESYS[®] is a trademark of CODESYS GmbH.

EtherCAT[®], *EtherCAT P*[®], *Safety over EtherCAT*[®], are trademarks or registered trademarks, licensed by Beckhoff Automation GmbH, Germany.

VESA[®] and *DisplayPort*[®] are registered trademarks of Video Electronics Standards Association (*VESA*[®]) in the United States and other countries.

Modbus[®] is a registered trademark of Schneider Automation Inc.

Torx[®], *Torx Plus*[®] are trademarks or registered trademarks of Acument Intellectual Properties, LLC in the United States or other countries.

Windows[®] is a registered trademark of Microsoft Corporation in the United States and other countries.

All trademarks are the properties of their respective owners.

Copyright

© Copyright DEIF A/S. All rights reserved.

Disclaimer

DEIF A/S reserves the right to change any of the contents of this document without prior notice.

The English version of this document always contains the most recent and up-to-date information about the product. DEIF does not take responsibility for the accuracy of translations, and translations might not be updated at the same time as the English document. If there is a discrepancy, the English version prevails.