

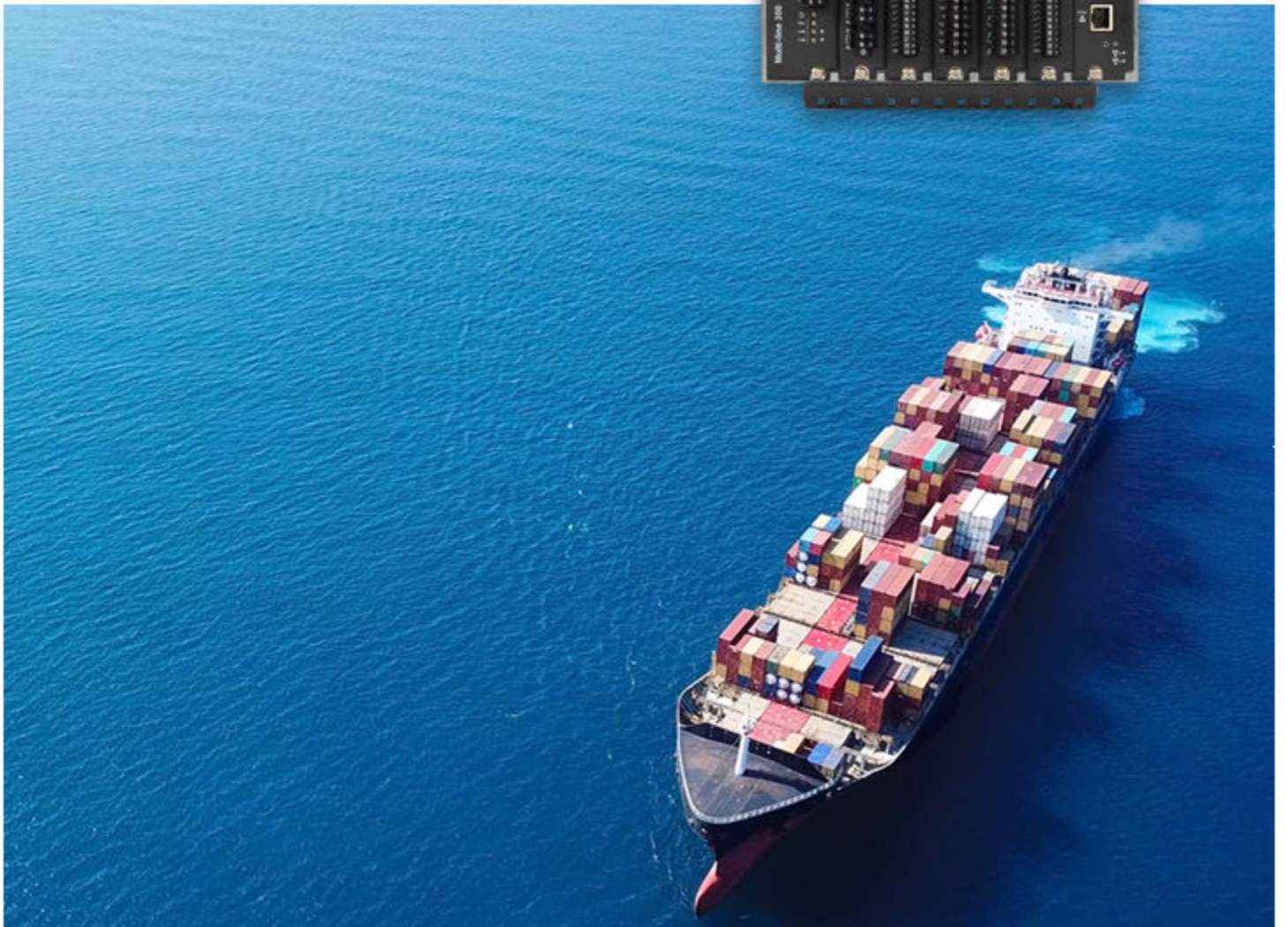
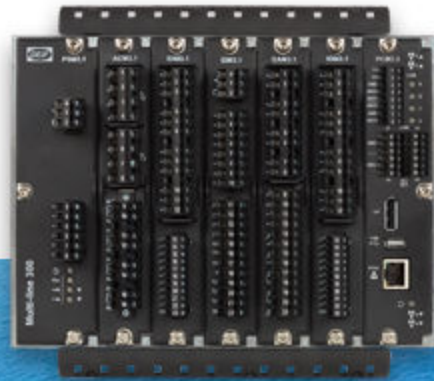
# iE 350 PLC

Programmable Automation Controller

## Installation instructions



Improve  
Tomorrow



## 1. About the installation instructions

1.1 Symbols and notation.....	5
1.2 Intended users of the Installation instructions.....	5
1.3 Warnings and safety.....	6
1.4 Legal information.....	7

## 2. Prepare for installation

2.1 Mount options.....	9
2.2 CAD drawings.....	9
2.3 Location.....	11
2.3.1 Rack R4.1 or R7.1.....	11
2.3.2 iE 7 Display.....	12
2.4 Tools.....	13
2.4.1 Rack R4.1 or R7.1.....	13
2.4.2 iE 7 Display.....	14
2.5 Additional materials.....	15
2.6 Personal Protective Equipment (PPE).....	15
2.7 Safety and precautions.....	16

## 3. Mount the equipment

3.1 Before you begin the installation.....	17
3.2 Base mount controller or rack.....	18
3.2.1 R4.1.....	18
3.2.1.1 R4.1 Rack dimensions.....	18
3.2.1.2 R4.1 Mounting hole dimensions.....	19
3.2.2 R7.1.....	20
3.2.2.1 R7.1 Rack dimensions.....	20
3.2.2.2 R7.1 Mounting hole dimensions.....	21
3.2.3 Mount on flat surface.....	22
3.2.4 Rack cable strain relief.....	23
3.3 Display.....	24
3.3.1 iE 7 display.....	24
3.3.2 Panel cutout.....	25
3.3.3 Mount the unit.....	26
3.3.4 iE 7 Display cable strain relief.....	27
3.4 Hardware modules.....	28
3.4.1 Change supplied configuration.....	28
3.4.2 Rack slot requirements.....	29
3.4.3 Change hardware modules.....	30
3.4.3.1 No hot swapping modules.....	30
3.4.3.2 Remove hardware modules.....	31
3.4.3.3 Mount hardware modules.....	33

## 4. Wiring the equipment

4.1 About the wiring.....	35
4.1.1 Technical specifications.....	35
4.1.2 Encoding pins for terminals.....	35
4.1.3 Wire up from left to right.....	35
4.2 Power supply module PSM3.1.....	36
4.2.1 PSM3.1 terminal connections.....	36
4.2.2 Frame ground wiring.....	36

4.2.3 Power supply wiring.....	37
4.2.4 Relay output wiring.....	38
4.2.5 PSM3.x EtherCAT connections.....	39
4.2.6 Topology examples.....	40
<b>4.3 Power supply module PSM3.2 (Extension rack).....</b>	<b>41</b>
4.3.1 PSM3.2 terminal connections.....	41
4.3.2 Frame ground wiring.....	41
4.3.3 Power supply wiring.....	42
4.3.4 Relay output wiring.....	43
4.3.5 PSM3.x EtherCAT connections.....	44
4.3.6 Topology examples.....	46
<b>4.4 Alternating current module ACM3.1.....</b>	<b>47</b>
4.4.1 ACM3.1 terminal connections.....	47
4.4.2 Voltage encoding pins for ACM3.1.....	48
4.4.3 Voltage measurements wiring.....	48
4.4.4 Current measurements wiring.....	49
<b>4.5 Differential current module ACM3.2.....</b>	<b>50</b>
4.5.1 ACM3.2 terminal connections.....	50
4.5.2 Current encoding pins for ACM3.2.....	50
4.5.3 Current measurements wiring.....	51
<b>4.6 Input/output module IOM3.1.....</b>	<b>52</b>
4.6.1 IOM3.1 terminal connections.....	52
4.6.2 Relay output wiring (changeover).....	52
4.6.3 Digital input wiring.....	53
<b>4.7 Input/output module IOM3.2.....</b>	<b>56</b>
4.7.1 IOM3.2 terminal connections.....	56
4.7.2 Relay output wiring.....	57
4.7.3 Analogue multifunctional current or voltage outputs wiring.....	58
4.7.4 Digital input wiring.....	59
4.7.5 Analogue multifunctional inputs wiring.....	61
<b>4.8 Input/output module IOM3.3.....</b>	<b>65</b>
4.8.1 IOM3.3 terminal connections.....	65
4.8.2 Analogue multifunctional inputs.....	65
4.8.3 Digital inputs wiring with wire break detection.....	66
4.8.4 Analogue current inputs wiring.....	66
4.8.5 Analogue voltage inputs wiring.....	67
4.8.6 Analogue resistance inputs wiring.....	67
4.8.7 Analogue thermocouple inputs wiring.....	69
<b>4.9 Input/output module IOM3.4.....</b>	<b>71</b>
4.9.1 IOM3.4 terminal connections.....	71
4.9.2 Digital output wiring.....	72
4.9.3 Digital input wiring.....	72
<b>4.10 Engine interface module EIM3.1.....</b>	<b>75</b>
4.10.1 EIM3.1 terminal connections.....	75
4.10.2 Frame ground wiring.....	75
4.10.3 Power supply wiring.....	76
4.10.4 Relay output wiring.....	77
4.10.5 Relay output with wire break detection.....	77
4.10.6 Digital input wiring.....	79
4.10.7 Magnetic pickup unit (MPU) input wiring.....	82

4.10.8 W input wiring.....	82
4.10.9 Analogue current or resistance inputs wiring.....	83
<b>4.11 Governor and AVR module GAM3.1.....</b>	<b>86</b>
4.11.1 GAM3.1 terminal connections.....	86
4.11.2 Relay output wiring.....	86
4.11.3 Analogue current or voltage outputs wiring.....	87
4.11.4 Analogue current or voltage input wiring.....	88
<b>4.12 Governor and AVR module GAM3.2.....</b>	<b>90</b>
4.12.1 GAM3.2 terminal connections.....	90
4.12.2 Frame ground wiring.....	91
4.12.3 Power supply wiring.....	91
4.12.4 Analogue current or voltage outputs wiring.....	92
4.12.5 Pulse width modulation (PWM) output wiring.....	93
4.12.6 Digital input wiring.....	93
4.12.7 Relay output wiring.....	96
<b>4.13 Processor and communication module PCM3.3.....</b>	<b>97</b>
4.13.1 PCM3.3 terminal connections.....	97
4.13.2 CAN bus ECU or DAVR communication.....	98
4.13.3 Serial communication COM 1 / COM 2.....	99
4.13.4 PCM3.3 Network connections.....	100
4.13.5 External third-party display.....	102
<b>4.14 Display.....</b>	<b>103</b>
4.14.1 iE 7 display Power supply.....	103
4.14.2 iE 7 display connections.....	104
<b>5. Maintenance</b>	
<b>5.1 Precautions before maintenance.....</b>	<b>105</b>
<b>5.2 Personnel and equipment protection.....</b>	<b>105</b>
<b>5.3 Rack slot requirements.....</b>	<b>107</b>
<b>5.4 Change hardware modules.....</b>	<b>108</b>
5.4.1 No hot swapping modules.....	108
5.4.2 Remove hardware modules.....	109
5.4.3 Mount hardware modules.....	111
<b>5.5 Replace RTC battery.....</b>	<b>113</b>
5.5.1 Location of RTC battery on PCM3.3 module.....	113
5.5.2 How to replace the RTC battery.....	114
<b>6. End-of-life</b>	
<b>6.1 Disposal of waste electrical and electronic equipment.....</b>	<b>117</b>

# 1. About the installation instructions

## 1.1 Symbols and notation

### Symbols for general notes

**NOTE** This shows general information.



**More information**

This shows where you can find more information.



**Example**

This shows an example.



**How to ...**

This shows a link to a video for help and guidance.

### Symbols for hazard statements



**DANGER!**



**This shows dangerous situations.**

If the guidelines are not followed, these situations will result in death, serious personal injury, and equipment damage or destruction.



**WARNING**



**This shows potentially dangerous situations.**

If the guidelines are not followed, these situations could result in death, serious personal injury, and equipment damage or destruction.



**CAUTION**



**This shows low level risk situation.**

If the guidelines are not followed, these situations could result in minor or moderate injury.

**NOTICE**



**This shows an important notice**

Make sure to read this information.

## 1.2 Intended users of the Installation instructions

The Installation instructions are primarily intended for the installer who mounts and wires up the controllers and/or displays. The Installation instructions can also be used for commissioning to check the installation.

## 1.3 Warnings and safety

### Safety during installation and operation

When you install and operate the equipment, you may have to work with dangerous currents and voltages. The installation must only be carried out by authorised personnel who understand the risks involved in working with electrical equipment.



**DANGER!**



#### **Hazardous live currents and voltages**

Do not touch any terminals, especially the AC measurement inputs or any relay terminals, as this could lead to injury or death.

### Disable the breakers (if applicable)



**DANGER!**



#### **Disable the breakers**

Unintended breaker closing can cause deadly and/or dangerous situations.

Disconnect or disable the breakers **BEFORE** you connect the controller power supply. Do not enable the breakers until **AFTER** the wiring and controller operation are thoroughly tested.

### Disable the engine start (if applicable)



**DANGER!**



#### **Unintended engine starts**

Unintended engine starts can cause deadly and/or dangerous situations.

Disconnect, disable or block the engine start (the crank and the run coil) **BEFORE** you connect the controller power supply. Do not enable the engine start until **AFTER** the wiring and controller operation are thoroughly tested.

### Metal fragments and other objects

Keep metal fragments and other objects out of the controller or display, as these can damage the equipment. Be especially careful when you install the equipment.

To prevent metal fragments from getting into the controller or extension rack, we recommend to place the supplied cover over the top ventilation holes when you install the rack. Remember to remove the cover after you finish the work. Failure to do so can damage the controller or extension rack.

### Electrostatic discharge



Protect the equipment terminals from electrostatic discharge when not installed in a grounded rack.

Electrostatic discharge could damage the equipment.

## Controller power supply

It is recommended that the controller has both a reliable power supply and a backup power supply. The switchboard design must ensure sufficient protection of the system, if the controller power supply fails.

## Connect the controller (or extension rack) protective earth



**DANGER!**



### Failure to ground

Failure to ground the controller (or extension rack) could lead to injury or death.

You must ground the controller (or extension rack) to a protective earth.

## Data security

The iE PLC includes a firewall.

While DEIF has taken great attention to data security and has designed the product to be a secure product, we recommend adopting Information Technology (IT) and Operational Technology (OT) security best practices when connecting the controller to a network.

To minimise the risk of data security breaches we recommend:

- Only connect to trusted networks and avoid public networks and the Internet.
- Use additional security layers like a VPN for remote access.
- Restrict access to authorised persons.

## 1.4 Legal information

### Third party equipment

DEIF takes no responsibility for installation or operation of any third party equipment. In no event shall DEIF be liable for any loss of profits, revenues, indirect, special, incidental, consequential, or other similar damages arising out of or in connection with any incorrect installation or operation of any third party equipment.

### Warranty

#### NOTICE

#### Warranty



The warranty will be lost if the warranty seals are broken. The rack may only be opened to remove, replace, and/or add a hardware module or the internal RTC battery (if fitted). The procedure in the *Installation instructions* must be followed. If the rack is opened for any other reason, and/or the procedure is not followed, then the warranty is void.

If the display is opened, then the warranty is void.

### Trademarks

DEIF and the DEIF logo are trademarks of DEIF A/S.

BELDEN is a trademark of BELDEN INC.

Adobe®, Acrobat®, and Reader® are either registered trademarks or trademarks of Adobe Systems Incorporated in the United States and/or other countries.

CANopen® is a registered community trademark of CAN in Automation e.V. (CiA).

SAE J1939® is a registered trademark of SAE International®.

CODESYS® is a trademark of CODESYS GmbH.

EtherCAT®, EtherCAT P®, Safety over EtherCAT®, are trademarks or registered trademarks, licensed by Beckhoff Automation GmbH, Germany.

VESA® and DisplayPort® are registered trademarks of Video Electronics Standards Association (VESA®) in the United States and other countries.

Google® and Google Chrome® are registered trademarks of Google LLC.

Linux® is a registered trademark of Linus Torvalds in the U.S. and other countries.

Modbus® is a registered trademark of Schneider Automation Inc.

Torx®, Torx Plus® are trademarks or registered trademarks of Acument Intellectual Properties, LLC in the United States or other countries.

Windows® is a registered trademark of Microsoft Corporation in the United States and other countries.

All trademarks are the properties of their respective owners.

## **Disclaimer**

DEIF A/S reserves the right to change any of the contents of this document without prior notice.

The English version of this document always contains the most recent and up-to-date information about the product. DEIF does not take responsibility for the accuracy of translations, and translations might not be updated at the same time as the English document. If there is a discrepancy, the English version prevails.

## **Copyright**

© Copyright DEIF A/S. All rights reserved.

## 2. Prepare for installation

### 2.1 Mount options

The iE 350 is highly flexible for different mounting locations.



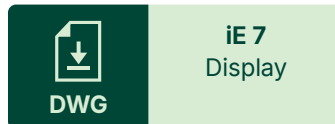
**NOTE** Contact DEIF for availability of some versions.

### 2.2 CAD drawings

#### CAD / DWG Drawings



[www.deif.com/rtd/ie350/cad](http://www.deif.com/rtd/ie350/cad)

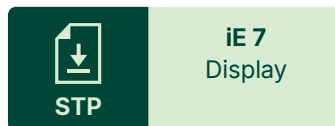


[www.deif.com/rtd/ie7/dwg](http://www.deif.com/rtd/ie7/dwg)

#### STP STEP-file



[www.deif.com/rtd/ie350/stp](http://www.deif.com/rtd/ie350/stp)



[www.deif.com/rtd/ie7/stp](http://www.deif.com/rtd/ie7/stp)

#### 2D PDF



[www.deif.com/rtd/ie350/2dpdf](http://www.deif.com/rtd/ie350/2dpdf)



[www.deif.com/rtd/ie7/2dpdf](http://www.deif.com/rtd/ie7/2dpdf)

#### 3D PDF

To view a 3D PDF you must enable multimedia and 3D content in your PDF viewer.



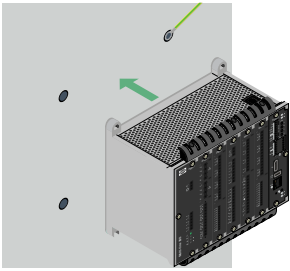
[www.deif.com/rtd/ie350/3dpdf](http://www.deif.com/rtd/ie350/3dpdf)



[www.deif.com/rtd/ie7/3dpdf](http://www.deif.com/rtd/ie7/3dpdf)

## 2.3 Location

### 2.3.1 Rack R4.1 or R7.1



The rack is designed to be mounted in an enclosure.

For UL/cUL listing, it must be:

- Mounted on a flat surface of a type 1 enclosure.
- Installed in accordance with the NEC (US) or the CEC (Canada).

The equipment must be installed and operated in a clean and dry environment, as specified in the **Data sheet**.

If the equipment is installed in an area subject to constant high vibrations, the equipment must be isolated from the vibrations. The installation environment must comply with the electrical, mechanical and environmental specifications of the equipment as described in the **Data sheet**.

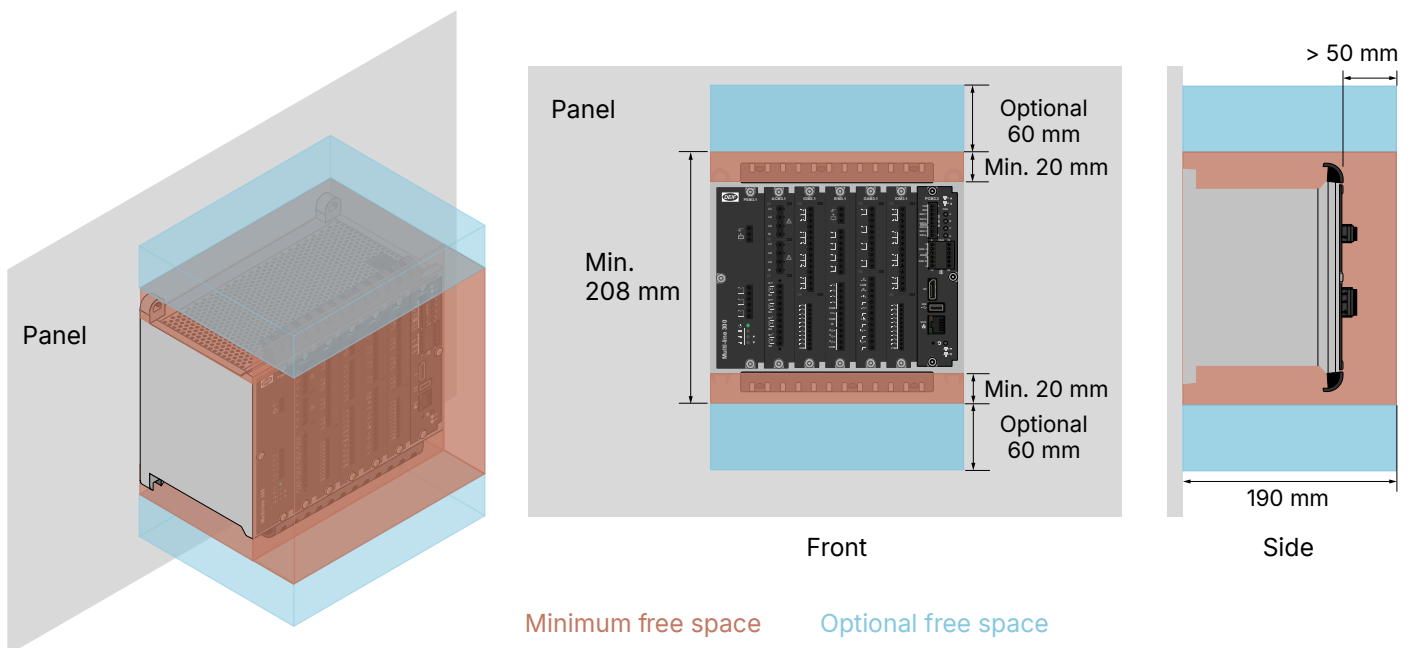
Protect the controller terminals from static discharge during installation, especially while the frame ground is not connected. The rack must be grounded.

#### Ventilation requirements and spacing

Dust accumulation may damage the unit or lead to overheating. We recommend mounting the unit in a cabinet with a filter on the air supply.

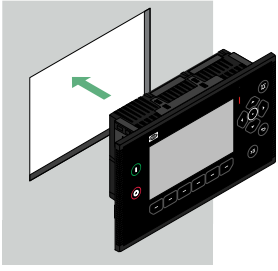
For proper ventilation, the unit must be mounted with its back vertical, and its long axis horizontal. The writing on the unit must be horizontal.

**NOTE** The cable routing must not block the ventilation holes.



Inside the cabinet, there must be a minimum of 20 mm (0.8 in) free space above, below of the unit. Some cables, for example Ethernet cables, may require a minimum cable bend radius. We recommend that you always follow the cable manufacturer's bend radius requirements.

## 2.3.2 iE 7 Display



The display is designed to be mounted in a panel, with its back in an enclosure.

For UL/cUL listing, it must be:

- Mounted on a flat surface of a type 1 enclosure.
- Installed in accordance with the NEC (US) or the CEC (Canada).

The display must be installed and operated in a clean and dry environment, as specified in the Data sheet.

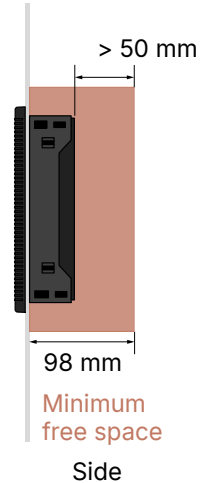
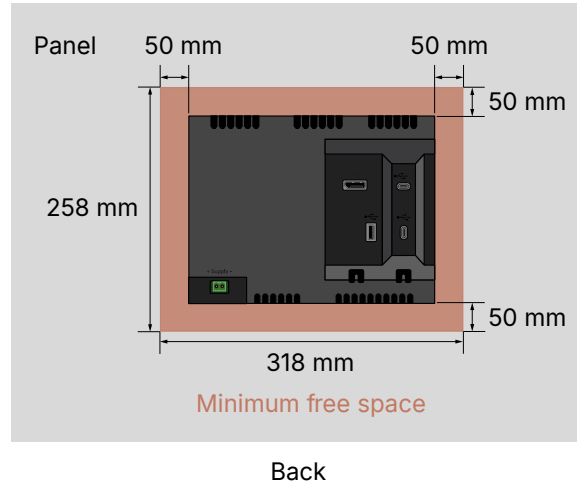
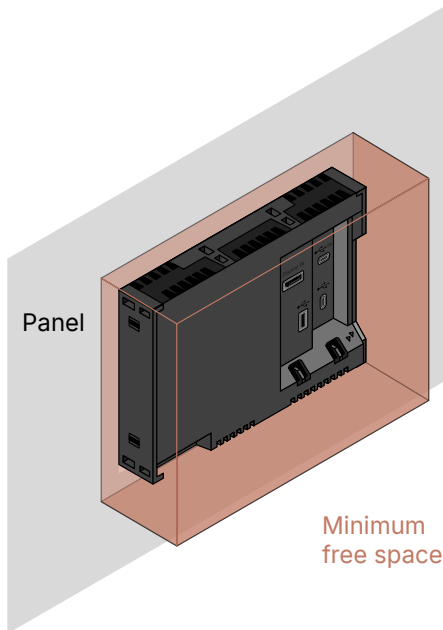
If the equipment is installed in an area subject to constant high vibrations, the equipment must be isolated from the vibrations. The installation environment must comply with the electrical, mechanical and environmental specifications of the equipment as described in the Data sheet.

### Ventilation requirements and spacing

The back of the display is not protected against dust. Dust accumulation may damage the unit or lead to overheating. We recommend mounting the unit in a cabinet with a filter on the air supply.

For proper ventilation, the unit must be mounted with its back vertical, and its long axis horizontal. The writing on the unit must be horizontal.

**NOTE** The display brightness may be affected if there is not enough ventilation.  
The cable routing must not block the ventilation holes.

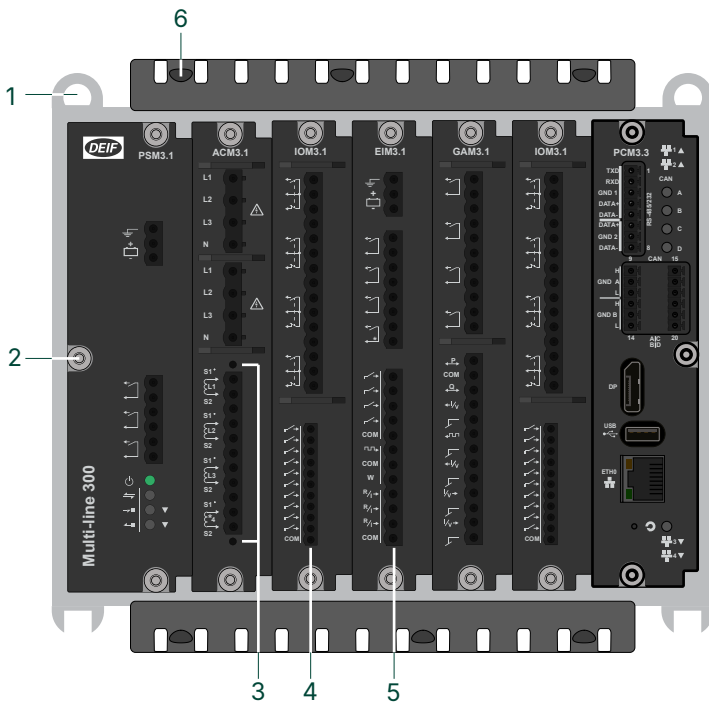


Inside the cabinet, there must be a minimum of 50 mm (2 in) free space above, below and at both sides of the unit. We recommend more than 50 mm (2 in) free space behind the unit for the cables and routing. Ethernet cables may require a minimum cable bend radius.

Total space requirement including minimum free space:  
**Height:** 258 mm **Width:** 318 mm **Depth:** 137 mm

## 2.4 Tools

### 2.4.1 Rack R4.1 or R7.1



#	Tool	Attachment	Torque	Used to
-	Screwdriver	PH2 bit or a 5 mm (0.2 in) flat-bladed bit	0.15 N·m (1.3 lb-in)	Tighten the display fixing screw clamps.
1.	Wrench *	10 mm hex socket for 6 mm nuts (7/16 in hex socket for 1/4 in nuts)	Enough torque to tighten to wall.	Tighten the nuts on the mounting bolts.
2.	Screwdriver	TX20 bit	0.5 N·m (4.4 lb-in)	Remove or add modules in the rack.
3.	Screwdriver.	3.5 mm (0.14 in) flat-bladed bit	0.25 N·m (2.2 lb-in)	Remove and secure the current measurement terminal block to the AC module faceplate.
4.	Screwdriver	2.5 mm (0.1 in) flat-bladed bit	0.25 N·m (2.2 lb-in)	Connect the wiring to the 1.5 mm <sup>2</sup> terminals.
5.	Screwdriver	3.5 mm (0.14 in) flat-bladed bit	0.5 N·m (4.4 lb-in)	Connect the wiring to the 2.5 mm <sup>2</sup> terminals.
6.	Screwdriver	TX10 bit	0.5 N·m (4.4 lb-in)	Remove or remount the cable strain relief plates.

**NOTE** \* The size of the torque wrench attachment depends on the nut and bolt size of the mounting bolts. These parts are not supplied by DEIF and the sizes mentioned are only a recommendation.

### NOTICE

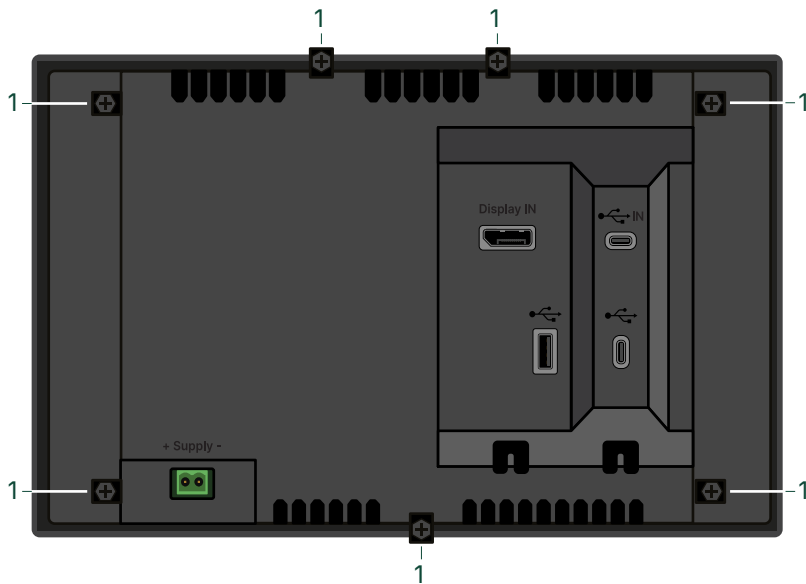


#### Torque damage to equipment

Do not use power tools during the installation. Too much torque damages the equipment.

Follow the instructions for the correct amount of torque to apply.

## 2.4.2 iE 7 Display



No.	Tool	Attachment	Torque	Used to
1.	Screwdriver	PH2 bit or a 5 mm (0.2 in) flat-bladed bit	0.1 N·m (0.9 lb-in)	Tighten the display unit fixing screw clamps.
-	Screwdriver	3 mm (0.12 in) flat-bladed bit	0.5 N·m (4.4 lb-in)	Connect the wiring to the 2.5 mm <sup>2</sup> terminals.

### NOTICE

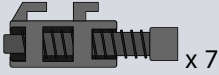



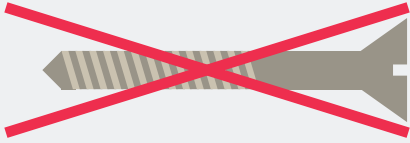




#### Torque damage to equipment

Do not use power tools during the installation. Too much torque damages the equipment.

Follow the instructions for the correct amount of torque to apply.

## 2.5 Additional materials

Material / Item	Version	Notes
Safety equipment	-	<b>Personal protection</b> according to local standards and requirements.
Conducting wrist strap	-	Prevent damage from electrostatic discharge.
Seven screw clamps	Display	To mount the display in the front panel.  x 7 Supplied with product.
Four bolts or screws	Controller or extension racks.	To mount the controller rack on a flat surface. <b>Screws</b>  <b>Bolts</b>  Not supplied with product.  Do not use countersunk screws or bolts. 
Cable ties	Controller or extension racks.	<b>R4.1 or R7.1</b> Max 2.5 mm  <b>iE 7 Display</b> Max 4.5 mm 
Wires and connectors	ALL	Wiring measuring points, DEIF equipment or any third party equipment to the controller terminals. Terminal blocks for the controller are supplied with product.
Ethernet cables	ALL	Connecting the controller communication between controllers, extension racks, and/or external systems.
USB cable	Controller rack	Connecting the controller to the display control.
DisplayPort cable	Controller rack	Connecting the controller to the display screen.
CAN cables	ALL	Connecting an ECU, DAVR, and/or external systems.
RS-282 or RS-485 cables	ALL	Connecting the controller via the communication ports COM 1 or COM 2. Only COM 1 supports RS-282.

## 2.6 Personal Protective Equipment (PPE)

Follow all local requirements and regulations for wearing PPE while you install or wire the product.

### Example PPE but not limited to:



Ear protection



Eye protection



Wear gloves



Protective clothing

## 2.7 Safety and precautions

When you install and wire the equipment, you may have to work with or near dangerous currents and voltages. The installation must only be carried out by authorised personnel who understand the risks involved in working with electrical equipment.

### Example safety precautions but not limited to:



Isolate power supply.



Ground the equipment.



Protect against static discharge.



Do not alter state during installation.



#### More information

See [Warnings and safety](#) for full details of all precautions to take during installation.

## 3. Mount the equipment

### 3.1 Before you begin the installation

The controller comes with the required hardware modules installed for the controller type. Additional modules can be added or removed on site.

If you replace a hardware module with a different type, the controller loses its maritime classification societies approvals. Replacing with a module of the same type will not affect maritime classification societies approvals.

The controller or extension rack is mounted in an enclosure. The display is mounted in a panel.

#### Changing the delivered configuration

You can mount the hardware modules in a different order from that recommended in these instructions. If you choose to do so, we recommend that you document the changes and include this information in the system documentation:

- Module name
- Module's rack slot number in the default configuration
- Module's rack slot number in your customised configuration

CAD drawings for both the controller, extension rack, and display can be downloaded from [www.deif.com](http://www.deif.com)



#### More information

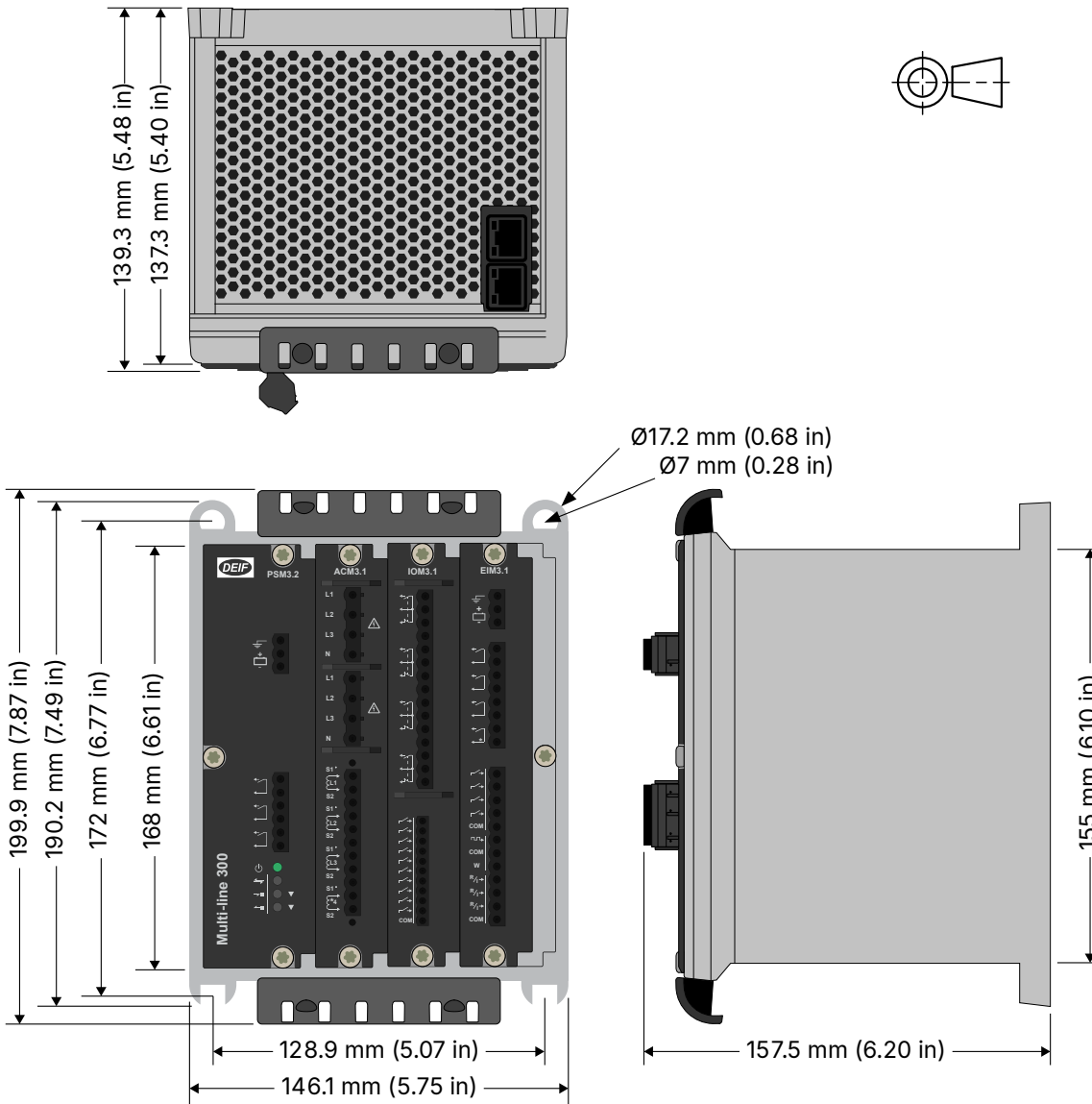
See [CAD drawings](#) for details and links to all the CAD files.

## 3.2 Base mount controller or rack

### 3.2.1 R4.1

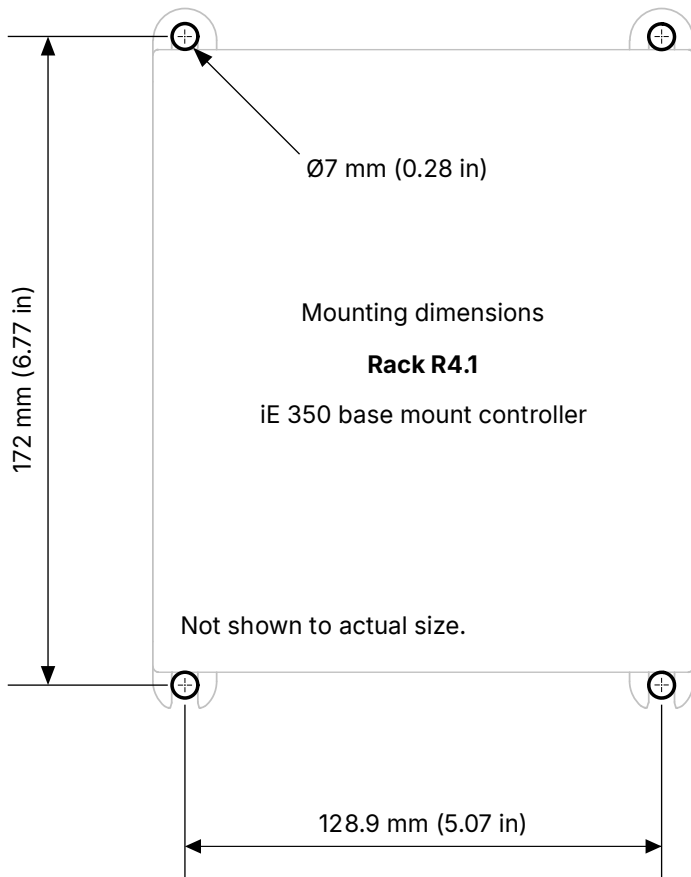
#### 3.2.1.1 R4.1 Rack dimensions

The racks are supplied with the cable strain relief plates mounted.



### 3.2.1.2 R4.1 Mounting hole dimensions

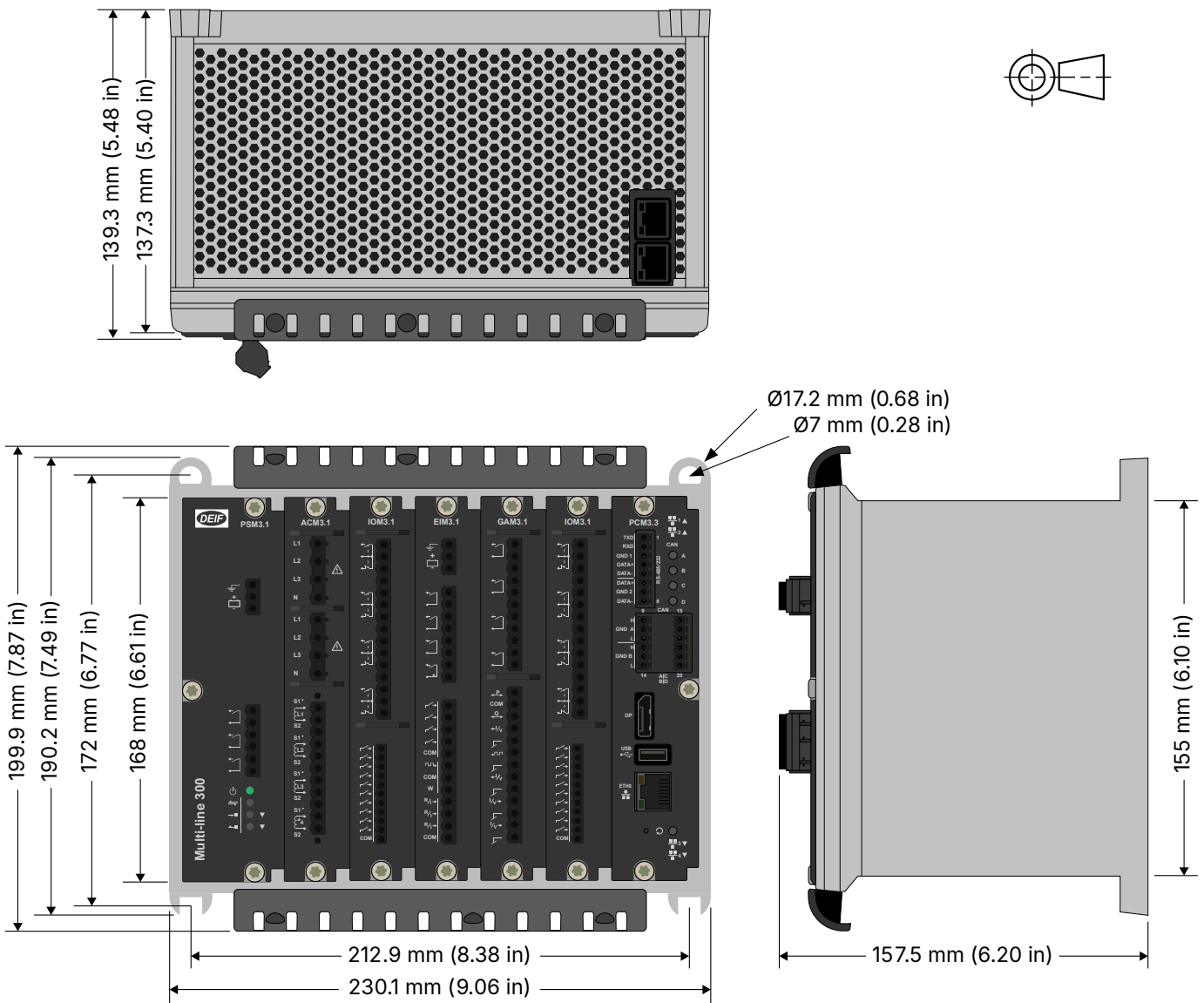
This dimension drawing is a guideline and not scale 1:1. The dimensions will not be correct when printed. Use the dimensions given to create your template.



### 3.2.2 R7.1

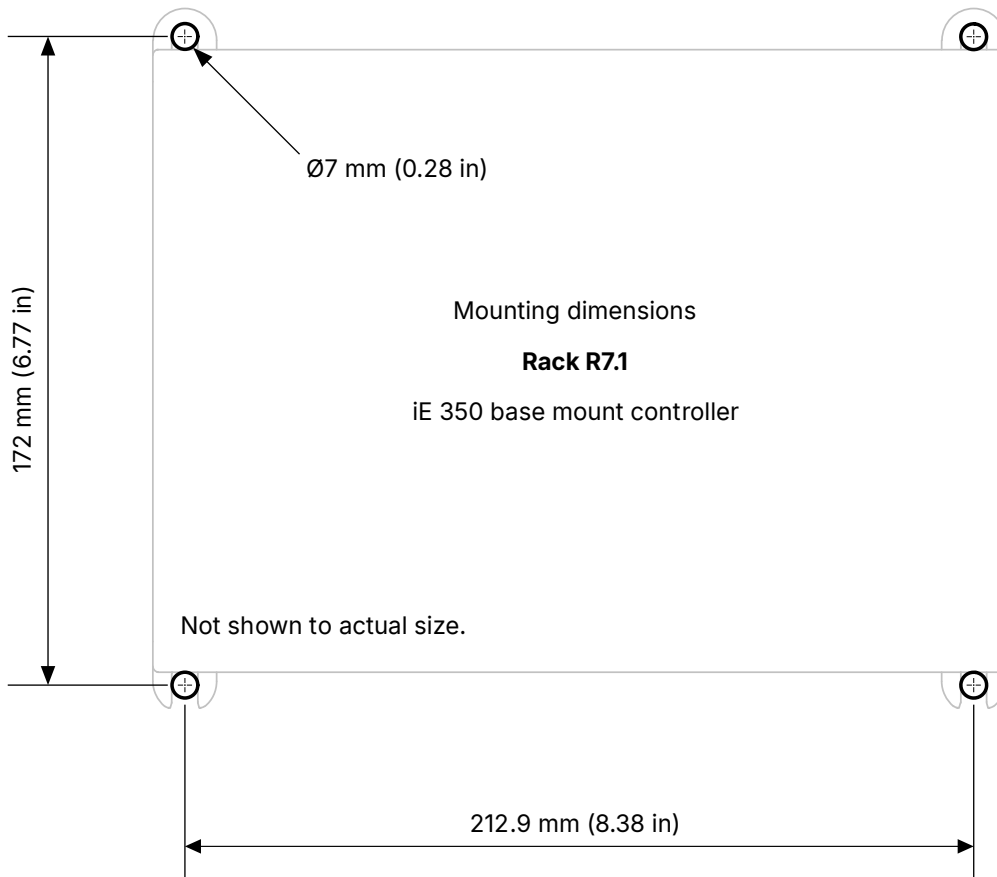
#### 3.2.2.1 R7.1 Rack dimensions

The racks are supplied with the cable strain relief plates mounted.



### 3.2.2.2 R7.1 Mounting hole dimensions

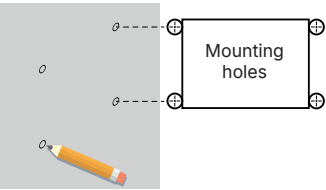
This dimension drawing is a guideline and not scale 1:1. The dimensions will not be correct when printed. Use the dimensions given to create your template.



### 3.2.3 Mount on flat surface

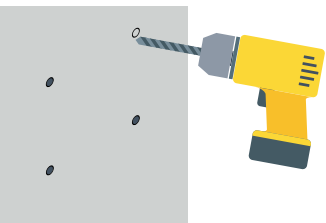
#### Fasteners for mounting the rack

Fasteners for mounting are **not** supplied with the controller. The base mount fasteners must be able to support the weight of the rack and the wiring. See [Materials](#) for required bolt or screw sizes.

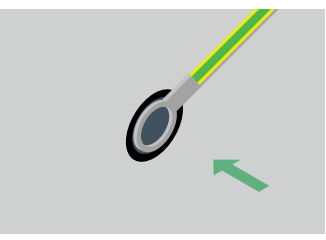
- 

1. Measure and mark the mounting holes on the surface.

  - For rack size R7.1 see [R7.1 Mounting hole dimensions](#).
  - For rack size R4.1 see [R4.1 Mounting hole dimensions](#).

- 

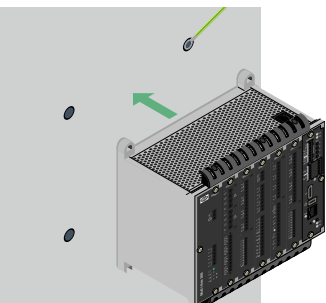
2. Drill and tap the holes for mounting the rack.

- 

3. Make sure to ground the controller or extension rack to a protective earth connection.

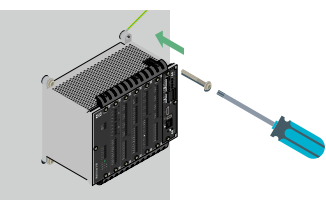
Use a grounding hoop with a toothed washer.

Galvanically connect the other end of the grounding wire to the grounding position of the enclosure.

- 

4. Align the base mount unit to the holes, including washers as needed.

Remember to include the grounding washer.

- 

5. Tighten all the fasteners until the unit is attached to the surface.

Do not overtighten the fasteners and damage the frame.

Do not exceed the recommended torque of 5 N·m (44 lb-in).



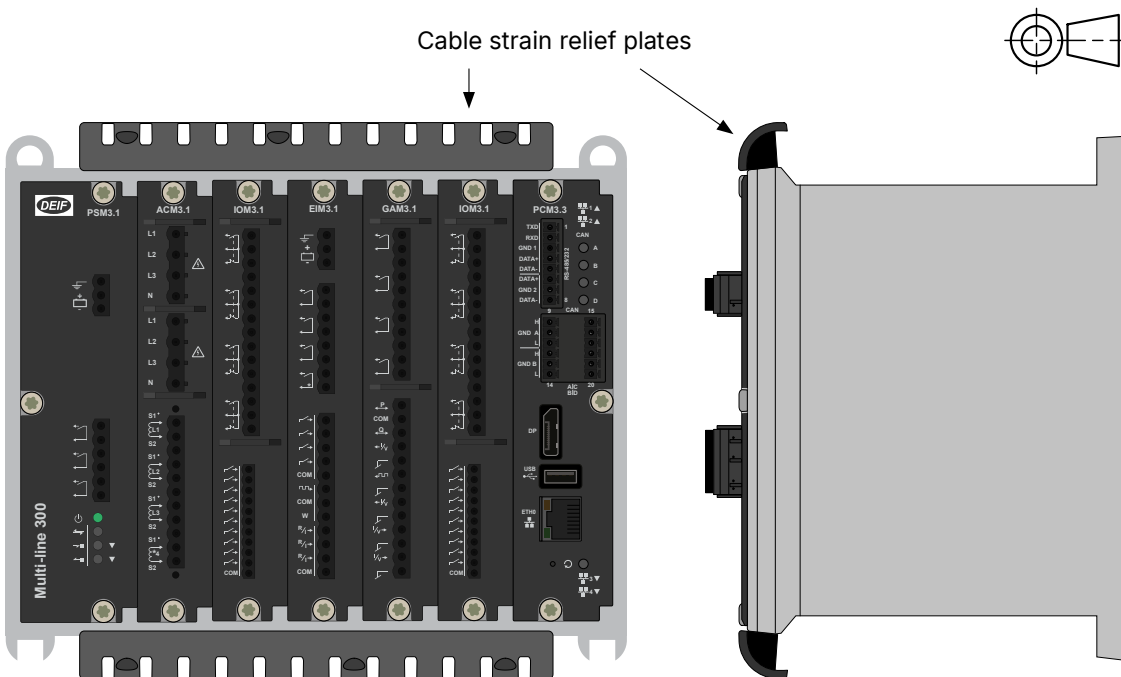
#### Failure to ground

Failure to ground the controller (or extension rack) could lead to injury or death.

You must ground the controller (or extension rack) to a protective earth.

### 3.2.4 Rack cable strain relief

Racks R4.1 and R7.1 have cable strain relief plates mounted at the top and the bottom. Use these to secure cables with cable ties.

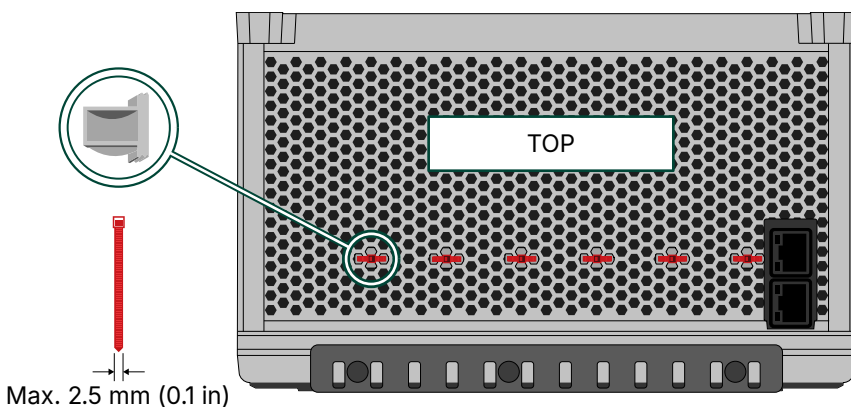


If needed, you can remove the plates by unscrewing the three 3 mm screws with a T10 screwdriver. When you remount a plate, tighten the screws with no more than 0.5 Nm (4.4 lb-in) of torque.

#### Cable tie slots

Rack R4.1 and R7.1 have cable tie slots inside the rack's aluminium frame. Rack R7.1 has six cable tie slots at the top, and six slots at the bottom. Rack R4.1 has four cable tie slots at the top, and six slots at the bottom.

The maximum cable tie width is 2.5 mm (0.1 in). The cable routing must not block more than 20 % of the ventilation holes.



### NOTICE

#### Maritime installations

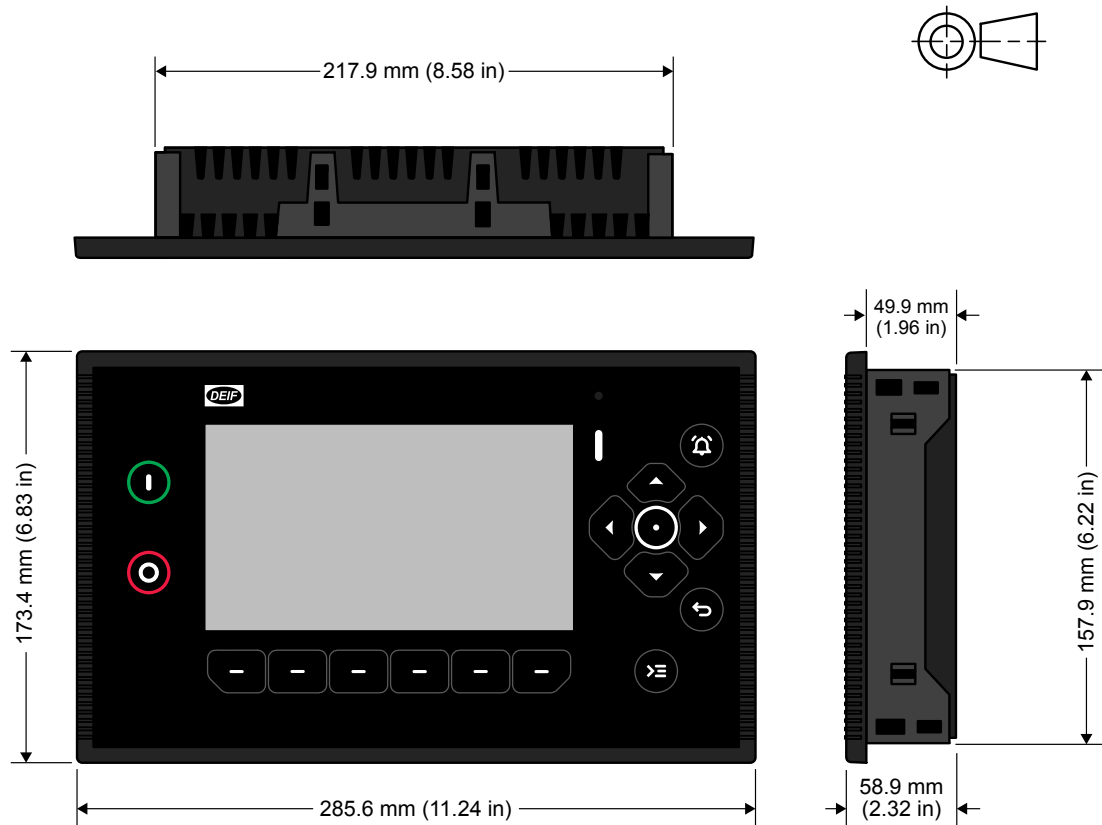


The cable tie slots are inside the rack's aluminium frame.

Only use them if the maritime classification societies' rules allow the wiring to be secured directly to metal. Alternatively, you can use extra insulation between the rack's frame and the wire.

### 3.3 Display

#### 3.3.1 iE 7 display

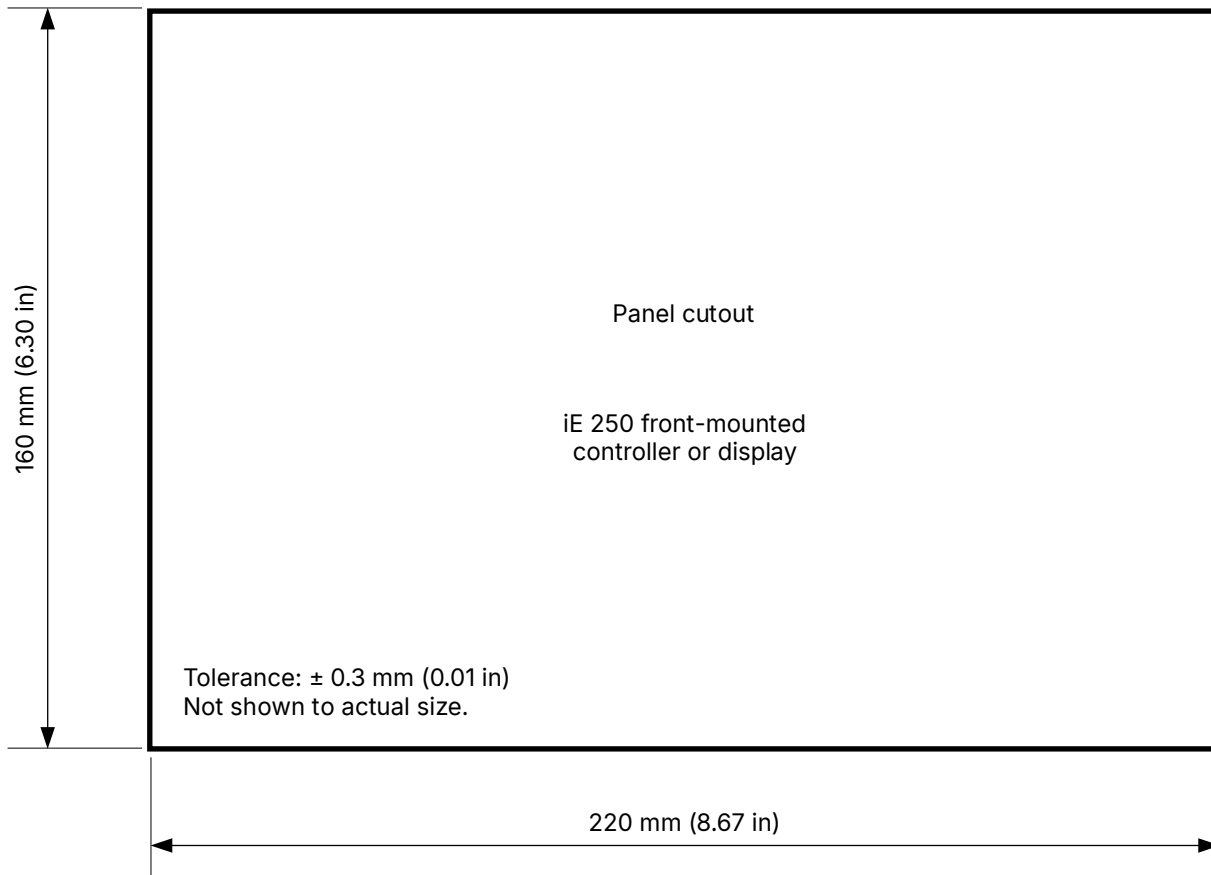


Category	Specifications
<b>Dimensions</b>	L×H×D: 285.6 × 173.4 × 58.9 mm (11.24 × 6.83 × 2.32 in) (outer frame)
<b>Panel cutout</b>	L×H: 220 × 160 mm (8.67 × 6.30 in)
<b>Weight</b>	840 g (1.9 lb)

Category	Specifications
<b>Display</b>	7", Projected Capacitive (PCAP), Touch
<b>Resolution</b>	1024x600 pixels (px)
<b>Brightness</b>	1200 Cd/m <sup>2</sup>
<b>Processor</b>	1.6 GHz quad-core industrial grade ARMv8 64 bit CPU with ECC protected cache

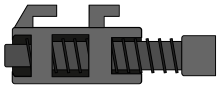
### 3.3.2 Panel cutout

This panel cutout drawing is a guideline and not scale 1:1. The dimensions will not be correct when printed. Use the dimensions given to create your panel cutout template.



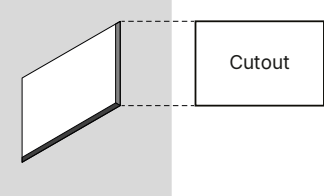
Panel thickness must be less than 10 mm (0.39 in).

### 3.3.3 Mount the unit



x 7

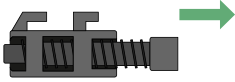
The unit is mounted with seven fixing screw clamps (supplied).

- 

Cut a rectangular hole in the panel to the correct size.

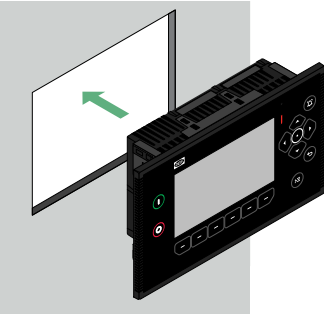
See [Panel cutout](#) for the dimensions of the cutout.

Panel thickness must be less than 10 mm (0.39 in).

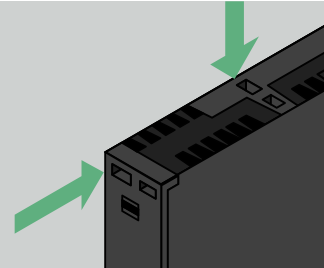
- 

Make sure that each fixing screw clamp is loosened to the position shown.

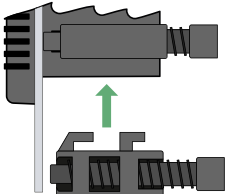
Do not remove the fixing screw clamp completely from the holder.

- 

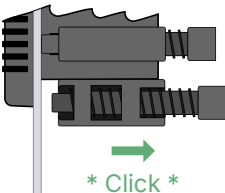
Put the unit into the panel cutout.

- 

Locate the holes for the fixing screw clamps on the unit.

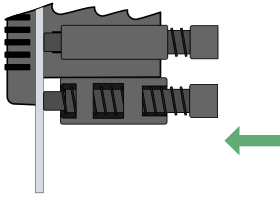
- 

Put each fixing screw clamp into the mounting holes.

- 

Slide each fixing screw clamp into position.

7.



Turn the fixing screw clamp until the unit is secure to the panel surface.

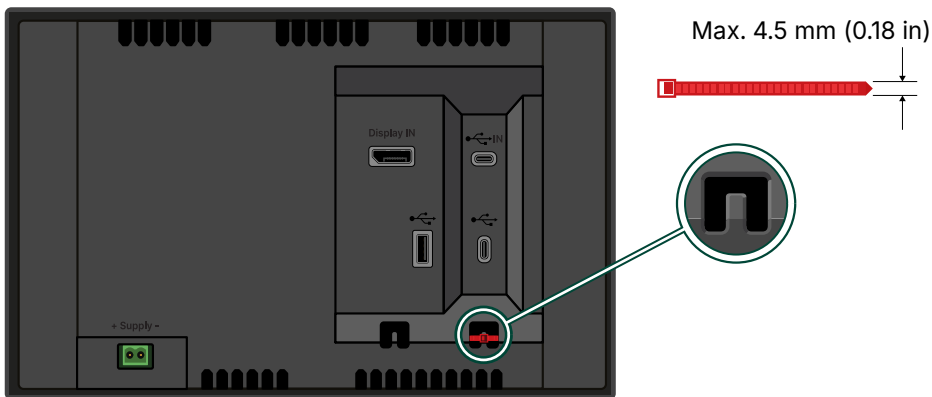
Do not exceed the recommended torque of 0.1 N·m (1.3 lb-in).

### 3.3.4 iE 7 Display cable strain relief

#### Cable tie slots

The iE 7 Display has two cable tie slots at the bottom of the display. For installations that may be subject to high vibrations, you must secure both the USB and DisplayPort cables using cable ties.

The maximum cable tie width is 4.5 mm (0.18 in).



## 3.4 Hardware modules

### 3.4.1 Change supplied configuration

The controller is normally supplied with the necessary hardware modules already mounted.

However, it is possible for you to add or replace the hardware modules before wiring and commissioning. If you need to add a hardware module, you must use the first empty slot from the left of the rack.

Make sure that changing the configuration does not affect any maritime classification societies approvals.

#### NOTICE



##### Correct handling of modules

Failure to follow these instructions could lead to damage to the modules.  
Read and follow the instructions to avoid damage to the modules.



#### CAUTION



##### Protecting equipment: No hot swapping

The rack must not be powered during the procedure. Make sure that any power supply is disconnected BEFORE replacing any modules.

#### NOTICE



##### Electrostatic discharge

During manufacturing and testing, the products have been kept in static shielding bags, and all personnel handling the products have been protected against static electricity and the subsequent ESD (electrostatic discharge).

Be sure to carry a connection to earth when handling our PCBs.

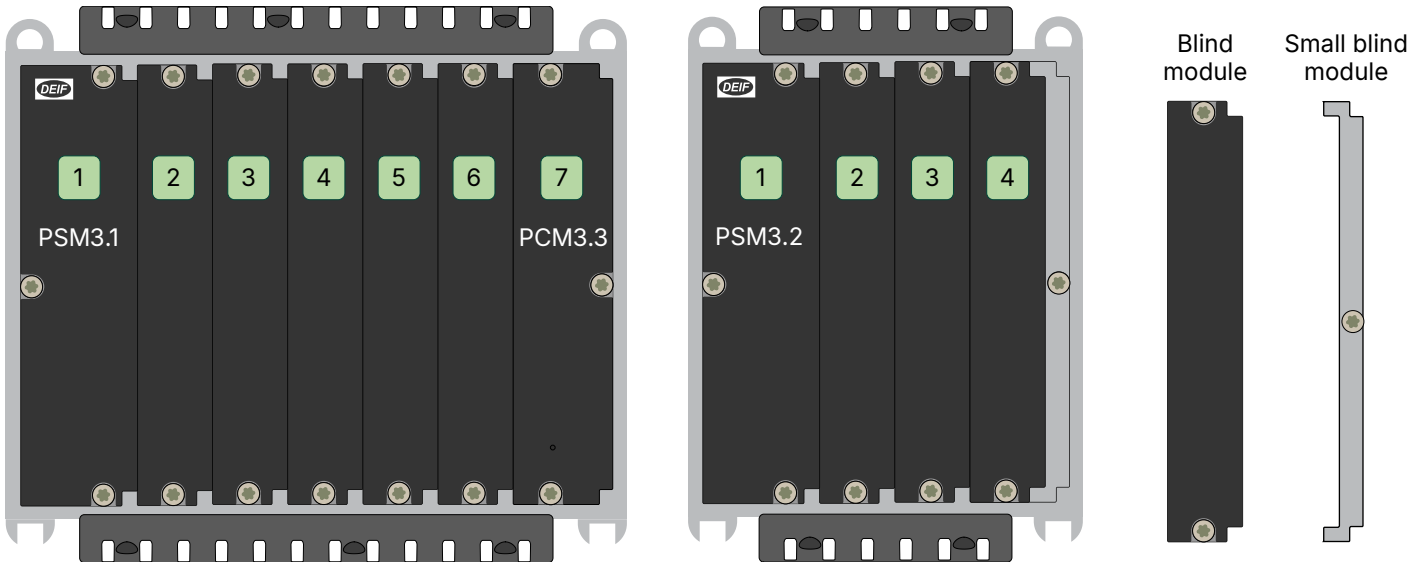
#### NOTICE



##### Torque damage to equipment

Do not use power tools during the installation/replacement. Too much torque damages the equipment.  
Follow the instructions for the correct amount of torque to apply.

### 3.4.2 Rack slot requirements



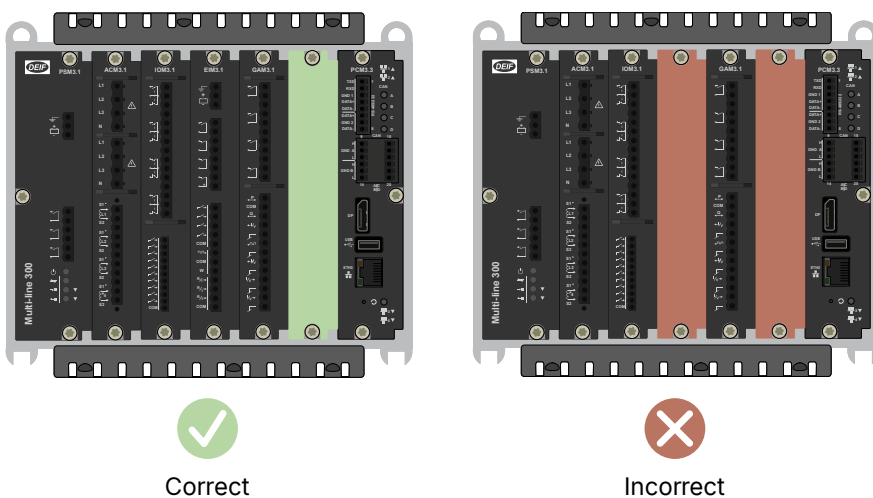
Modules can be installed in either rack R7.1 (7 slots) or R4.1 (4 slots). The modules can be arranged in any order in the rack, but must comply with these requirements.

R7.1 (7 slots)		R4.1 (4 slots)	
Controllers	Extension racks	Controllers	Extension racks
Slot 1 must have the <b>PSM3.1</b> .	Slot 1 must have the <b>PSM3.2</b> .	Slot 1 must have the <b>PSM3.1</b> .	Slot 1 must have the <b>PSM3.2</b> .
Slot 7 must have the <b>PCM3.3</b> .	Other modules can be used in slot 7 but must have the <b>small blind module</b> .	Slot 4 must have the <b>PCM3.3</b> .	Other modules can be used in slot 4 but must have the <b>small blind module</b> .
Blind modules (blank faceplates) must be installed over empty slots to protect the rack.			

#### Order of the modules

All other hardware modules must installed from left to right from slot 2 onwards without empty slots between modules.

There can only be adjacent empty slots between the last module and the **PCM3.3** or end of the rack.



If slots are empty between the hardware modules, the modules after the empty slot(s) **cannot communicate** with the **PCM3.3** module.

### 3.4.3 Change hardware modules

Each module is fastened to the rack with TX20 screws.

These should be loosened before the extraction handles are used to lift the module free of the rack.

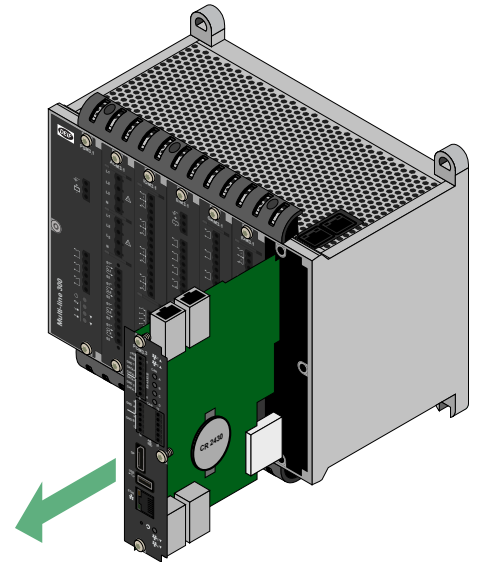
They do not remove completely from the hardware module.

Hold the module by the faceplate. Do **not** touch the PCB.



#### More information

See [Maintenance](#) for how to change the PCM battery.



#### 3.4.3.1 No hot swapping modules



**DANGER!**

##### Do not hot swap modules



It is not allowed to hot swap any modules. Hot swapping modules can be extremely dangerous to both personnel and the equipment.

Make sure the system is shutdown and power supply has been isolated and switched off.



Isolate the power supply.



Protect the modules against static discharge.



Do not alter state during installation.




Avoid touching the PCB or terminal pins.



#### More information

See [Warnings and safety](#) for full details of all precautions to take during installation.

### 3.4.3.2 Remove hardware modules

1.  Protect the hardware modules against static discharge.

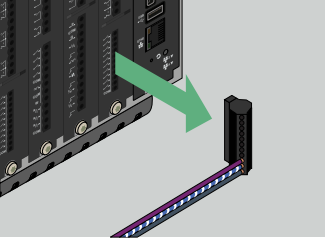


It is recommended to use a wrist strap connection to protect against Electrostatic discharge (ESD).

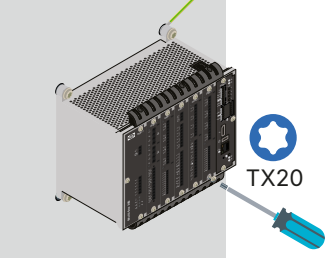
Test the resistance of the wrist strap and the wrist strap connection. **Do not continue** if the wrist strap connection is faulty. Use the wrist strap at all times while installing or uninstalling any modules.

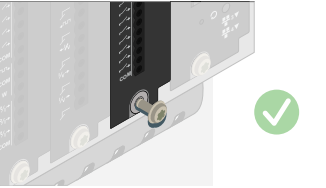
2.  The controller **must not be powered**.

Disconnect all power supplies to protect the hardware modules and personnel.

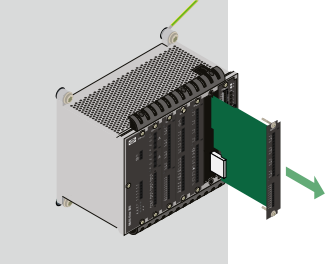
3.  Remove all terminal blocks, and make sure that there are no wires in the way of removing the hardware module.

For PSM or PCM modules, disconnect any Ethernet cables from the top and bottom.

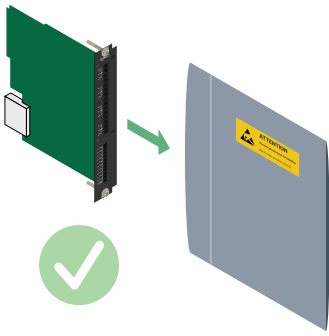
4.  Loosen the module faceplate screws with a TX20 screwdriver.

5.  Do not force the screws to unscrew completely.

The screws are built-in and should remain attached to the faceplate.

6.  Use pliers or your fingers to pull the faceplate screws, and carefully slide the hardware module out of the rack.

7.



Hold the module by the faceplate.

Do **not** touch the PCB.

Put the hardware module in an ESD protective package when not installed in the rack.

### 3.4.3.3 Mount hardware modules

1. Protect the hardware modules against static discharge.



It is recommended to use a wrist strap connection to protect against Electrostatic discharge (ESD).

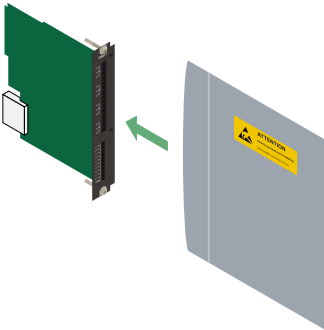
Test the resistance of the wrist strap and the wrist strap connection. **Do not continue** if the wrist strap connection is faulty. Use the wrist strap at all times while installing or uninstalling any modules.

2. The controller **must not be powered**.

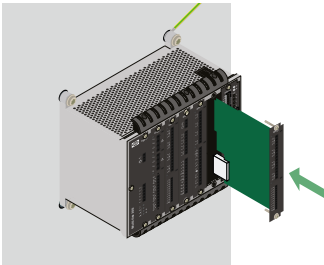


Disconnect all power supplies to protect the hardware modules and personnel.

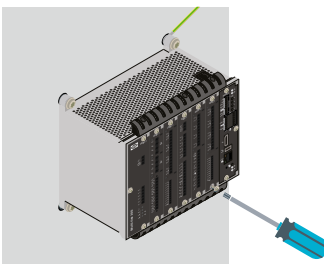
3. Open the ESD protective package, and remove the new module, hold it only by the faceplate.



4. Slide the module into the correct slot (it should slide in easily).

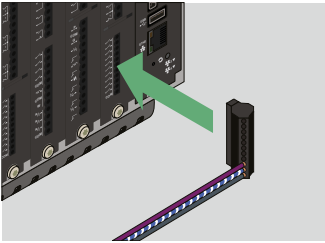


5. Tighten the screws on the module faceplate with a TX20 screwdriver.



Do not exceed the recommended torque of 0.5 N·m (4.4 lb-in).

6.



Replace all terminal blocks.

For PSM or PCM modules, replace any Ethernet cables to the top and bottom.

7.



If the rack is not mounted, return the rack to its protective packaging.

## 4. Wiring the equipment

### 4.1 About the wiring

#### 4.1.1 Technical specifications

You can find all of the technical specifications in the Data sheet:

- [iE 350 Data sheet](#)
- [iE 350 Marine Data sheet](#)
- [iE 350 PLC Data sheet](#)

#### 4.1.2 Encoding pins for terminals

Use encoding pins to prevent the terminal blocks from being mounted incorrectly. Make sure the terminal wiring was not swapped around during the installation, as this could lead to dangerous situations. We strongly recommend that you use encoding pins on both ACM3.1 and ACM3.2 for both voltage and current respectively. You can also use encoding pins on other terminals and modules.

For safety reasons the encoding pins should not be reused. Once they are installed it is difficult to remove the pins without damaging the equipment.

#### Optional installation equipment

Tool	Function
Long nose pliers	Improves the handling and placement of the voltage encoding pins.



#### More information

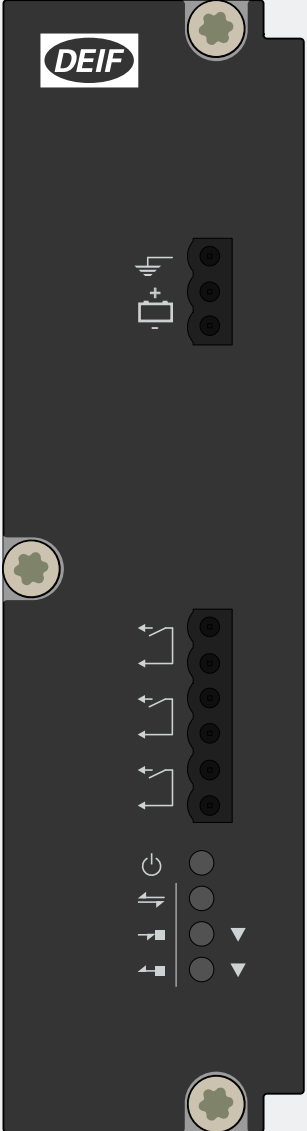











See [Voltage encoding pins for ACM3.1](#) and [Current encoding pins for ACM3.2](#) for how to install the encoding pins in the module.

#### 4.1.3 Wire up from left to right

We recommend that you wire up the controller (or extension rack) from left to right. As the wiring connects to the left side of each 45° terminal block, they may otherwise extend over and obstruct the module to the left.

## 4.2 Power supply module PSM3.1

### 4.2.1 PSM3.1 terminal connections

	Term	Symbol	Name	Type	Default
	F/G		F/G	Ground	Frame ground
	1		+	12 or 24 V DC (nominal)	Power supply
	2		-	0 V DC	
	3		Normally open	Relay output (30 V DC and 1 A)	... > Status OK *
	4		Common		
	5		Normally open		(Configurable)
	6		Common		
	7		Normally open		(Configurable)
	8		Common		
	IN		EtherCAT communication input **		RJ45 (bottom of rack, top port)
OUT		EtherCAT communication output **	RJ45 (bottom of rack, bottom port)		Output *

**NOTE** \* Default function cannot be changed.

\*\* EtherCAT communication connections are only for communication to extension racks.

### 4.2.2 Frame ground wiring

Create a protective earth:

1. Connect the frame ground terminal to the protective earth connection.
2. Connect the frame ground terminal to the cabinet.
3. Connect the rack to the cabinet.

The frame ground is connected to the power supply terminals through transient voltage suppression diodes (transorbs). In order to protect the frame ground and power supply, max. 36 V is allowed between the frame ground and the power supply terminals.

### 4.2.3 Power supply wiring

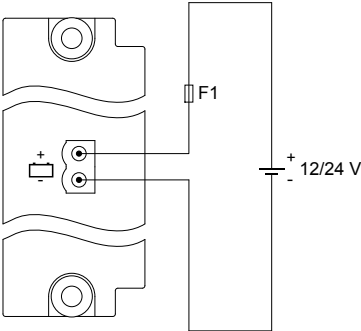
Connect the power supply (+) to the 12 or 24 V DC power supply, and the power supply (-) to the 0 V DC power supply.

#### NOTICE

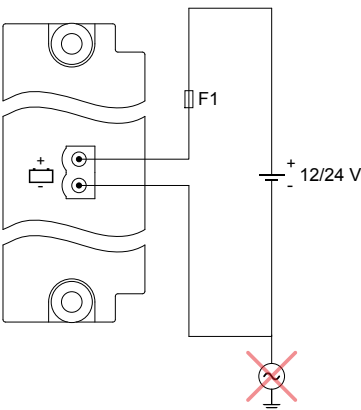
##### Negative power supply terminal

Do not wire the negative power supply terminal of the modules with independent power supplies (for example, PSM 3.1) to the single-phase ground. If the voltage between the power supply terminals and frame ground exceeds 36 V, the power supply terminals and the frame ground terminal will be damaged.

##### Recommended wiring for the power supply



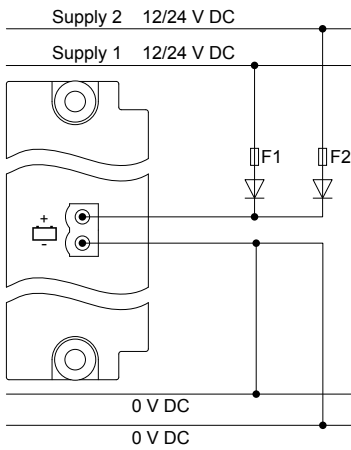
##### Incorrect wiring of the power supply



##### Backup power supply

The equipment does not contain a backup power supply. The power supply source must therefore include the necessary power backup.

## Example of a power supply and backup connected to the power supply terminals



We recommend a 2 A time-delay fuse for 24 V DC and a 4 A time-delay fuse for 12 V DC for F1 and F2, and that the diodes are rated 50V or higher.

### NOTICE

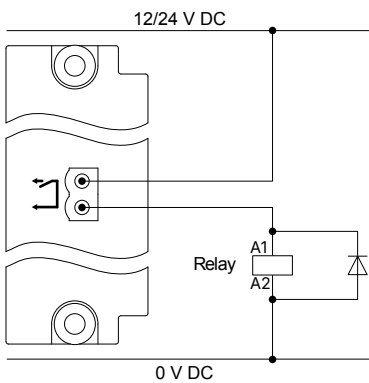


**Nominal auxiliary voltage is 12 or 24V DC (8 to 36 V DC operating range).**

If voltage drops are likely to appear, a 7 A time-delay fuse is needed.

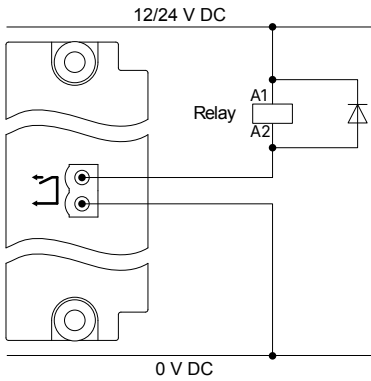
## 4.2.4 Relay output wiring


The diagram shows the connection of the relay output to an external relay. There is no voltage on the external relay when the controller relay is open.



Use a diode size as recommended by the relay supplier.

You can swap the terminal connections around without affecting the performance.

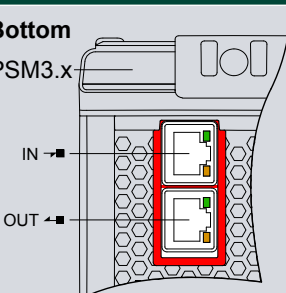


Install a freewheeling diode (  ) to prevent a sudden voltage spike across the inductive load when the voltage source is removed.

## 4.2.5 PSM3.x EtherCAT connections

Extension racks are connected to controller with the EtherCAT communication ports on the PSM3.1 and PSM3.2. These ports are marked in red on the controller and extension rack.

**Table 4.1** Location of the EtherCAT communication ports

Symbol	Symbol	Port location	Notes
 <p>Bottom PSM3.x</p> <p>IN →</p> <p>OUT ←</p>	IN →	Bottom of rack, top port	<b>EtherCAT communication:</b> IN port from other rack
	OUT ←	Bottom of rack, bottom port	<b>EtherCAT communication:</b> OUT port to other rack

### EtherCAT communication restrictions

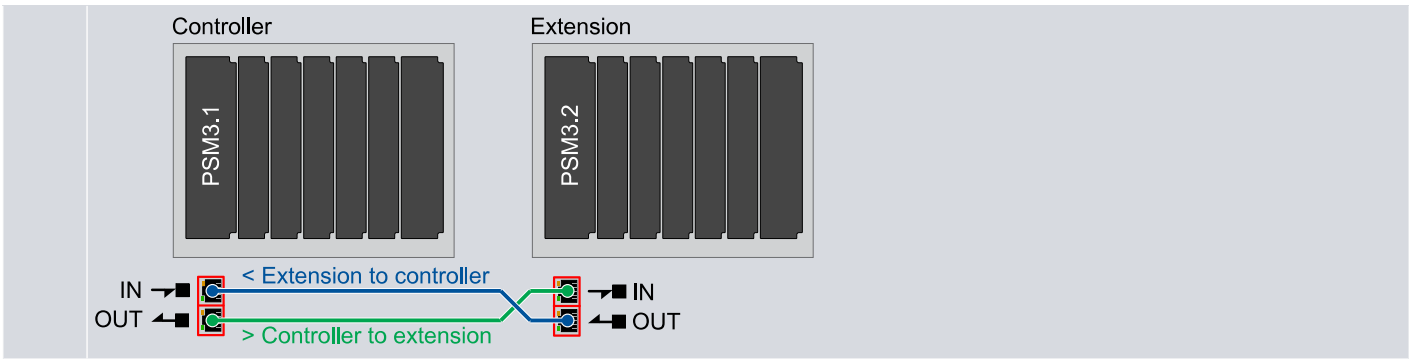
The racks have an OUT port and an IN port for EtherCAT communication. The OUT port must always be connected to an IN port on the next extension rack.

- With 1 extension rack, you can optionally create a ring network by connecting the last extension rack back to the controller.
- With 2 or more extension racks, you must create a ring network by connecting the last extension rack back to the controller.
- Number of extension racks is limited by EtherCAT data amount and cycle time.
- The cables must not be longer than 100 metres from point-to-point.
- The cables must meet or exceed the SF/UTP CAT5e specification.
- Controller and extension rack must be connected directly without a switch between them.



#### How to connect a ring connection

The controller is connected to the extension rack. The extension rack is connected back to the controller.



Power off the extension racks before you exchange or re-connect them to another controller.

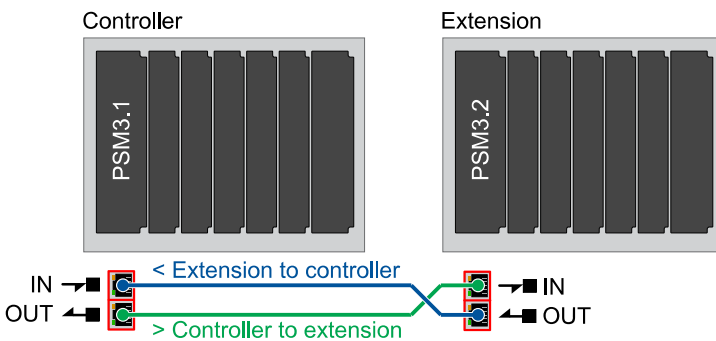
### Cable bend radius

Bends in the Ethernet cables must not be tighter than the minimum bend radius specified by the cable manufacturers. We recommend that you always follow the cable manufacturer's bend radius requirements. It is recommended to use velcro-strips and not cable-ties for the Ethernet cables.

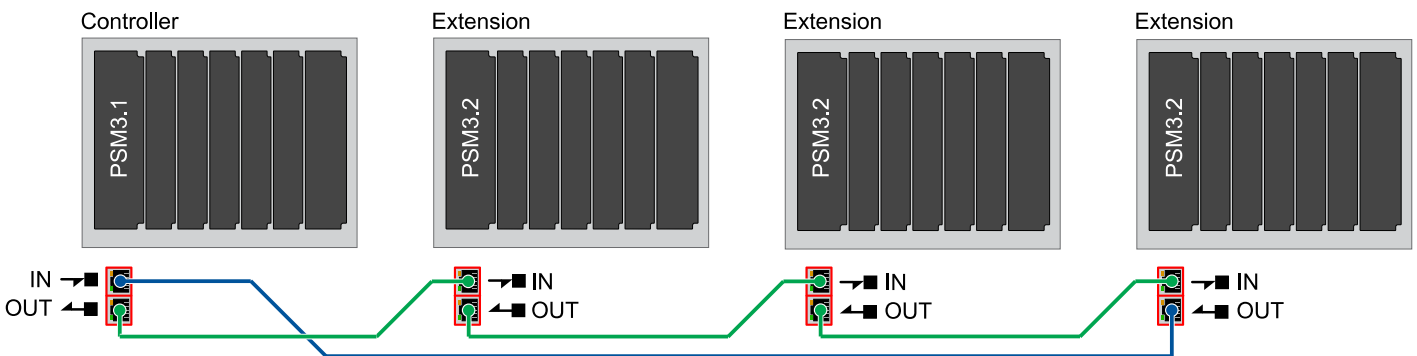
## 4.2.6 Topology examples

EtherCAT communication must be connected only in a chain or ring configuration. Ring configuration provides redundant communication, should one connection be damaged.

### Chain (single connection)

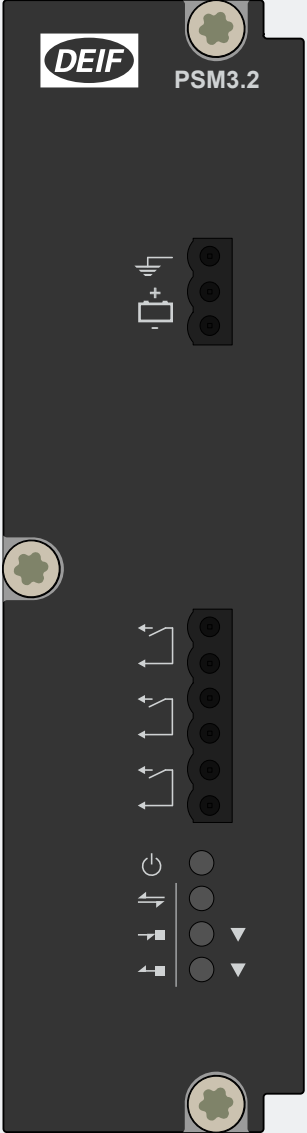













### Ring (redundancy connection)



## 4.3 Power supply module PSM3.2 (Extension rack)

### 4.3.1 PSM3.2 terminal connections

	Term	Symbol	Name	Type	Default
	F/G		F/G	Ground	Frame ground
	1		+	12 or 24 V DC (nominal)	Power supply
	2		-	0 V DC	
	3		Normally open	Relay output (30 V DC and 1 A)	Configurable
	4		Common		
	5		Normally open		
	6		Common		
	7		Normally open		
	8		Common		
	IN		EtherCAT communication input **		RJ45 (bottom of rack, top port)
OUT		EtherCAT communication output **	RJ45 (bottom of rack, bottom port)		Output *

**NOTE** \* Default function cannot be changed.

\*\* EtherCAT communication connections are only for communication to extension racks.

### 4.3.2 Frame ground wiring

Create a protective earth:

1. Connect the frame ground terminal to the protective earth connection.
2. Connect the frame ground terminal to the cabinet.
3. Connect the rack to the cabinet.

The frame ground is connected to the power supply terminals through transient voltage suppression diodes (transorbs). In order to protect the frame ground and power supply, max. 36 V is allowed between the frame ground and the power supply terminals.

### 4.3.3 Power supply wiring

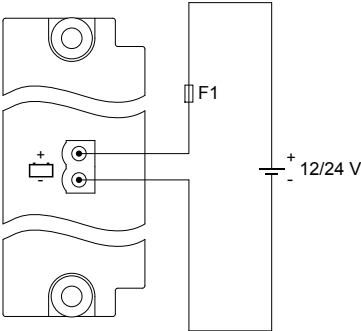
Connect the power supply (+) to the 12 or 24 V DC power supply, and the power supply (-) to the 0 V DC power supply.

#### NOTICE

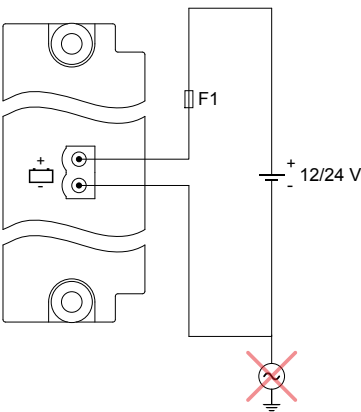
##### Negative power supply terminal

Do not wire the negative power supply terminal of the modules with independent power supplies (for example, PSM 3.1) to the single-phase ground. If the voltage between the power supply terminals and frame ground exceeds 36 V, the power supply terminals and the frame ground terminal will be damaged.

##### Recommended wiring for the power supply



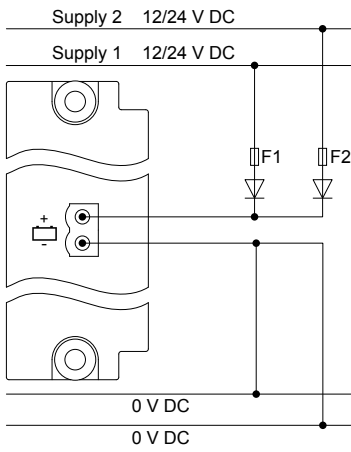
##### Incorrect wiring of the power supply



##### Backup power supply

The equipment does not contain a backup power supply. The power supply source must therefore include the necessary power backup.

## Example of a power supply and backup connected to the power supply terminals



We recommend a 2 A time-delay fuse for 24 V DC and a 4 A time-delay fuse for 12 V DC for F1 and F2, and that the diodes are rated 50V or higher.

### NOTICE

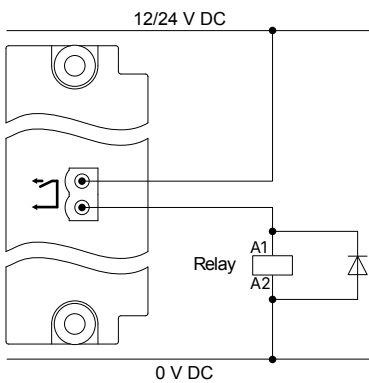


**Nominal auxiliary voltage is 12 or 24V DC (8 to 36 V DC operating range).**

If voltage drops are likely to appear, a 7 A time-delay fuse is needed.

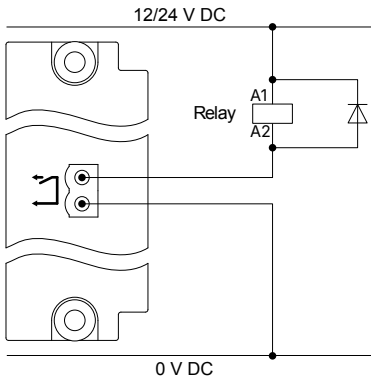
### 4.3.4 Relay output wiring


The diagram shows the connection of the relay output to an external relay. There is no voltage on the external relay when the controller relay is open.



Use a diode size as recommended by the relay supplier.

You can swap the terminal connections around without affecting the performance.

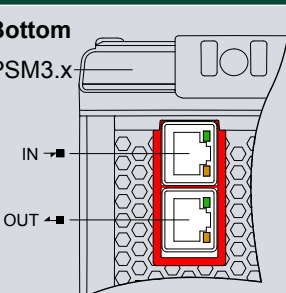


Install a freewheeling diode (  ) to prevent a sudden voltage spike across the inductive load when the voltage source is removed.

### 4.3.5 PSM3.x EtherCAT connections

Extension racks are connected to controller with the EtherCAT communication ports on the PSM3.1 and PSM3.2. These ports are marked in red on the controller and extension rack.

**Table 4.2** Location of the EtherCAT communication ports

Symbol	Symbol	Port location	Notes
 <p>Bottom PSM3.x</p> <p>IN →■</p> <p>OUT ←■</p>	IN →■	Bottom of rack, top port	<b>EtherCAT communication:</b> IN port from other rack
	OUT ←■	Bottom of rack, bottom port	<b>EtherCAT communication:</b> OUT port to other rack

### EtherCAT communication restrictions

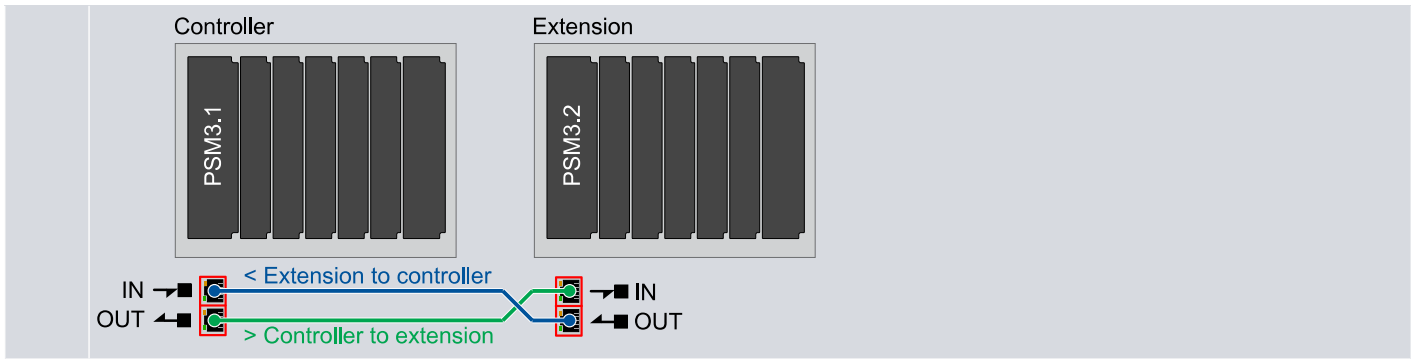
The racks have an OUT port and an IN port for EtherCAT communication. The OUT port must always be connected to an IN port on the next extension rack.

- With 1 extension rack, you can optionally create a ring network by connecting the last extension rack back to the controller.
- With 2 or more extension racks, you must create a ring network by connecting the last extension rack back to the controller.
- Number of extension racks is limited by EtherCAT data amount and cycle time.
- The cables must not be longer than 100 metres from point-to-point.
- The cables must meet or exceed the SF/UTP CAT5e specification.
- Controller and extension rack must be connected directly without a switch between them.



#### How to connect a ring connection

The controller is connected to the extension rack. The extension rack is connected back to the controller.



Power off the extension racks before you exchange or re-connect them to another controller.

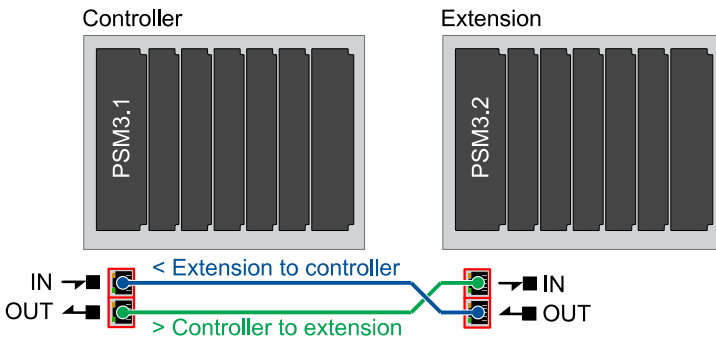
### Cable bend radius

Bends in the Ethernet cables must not be tighter than the minimum bend radius specified by the cable manufacturers. We recommend that you always follow the cable manufacturer's bend radius requirements. It is recommended to use velcro-strips and not cable-ties for the Ethernet cables.

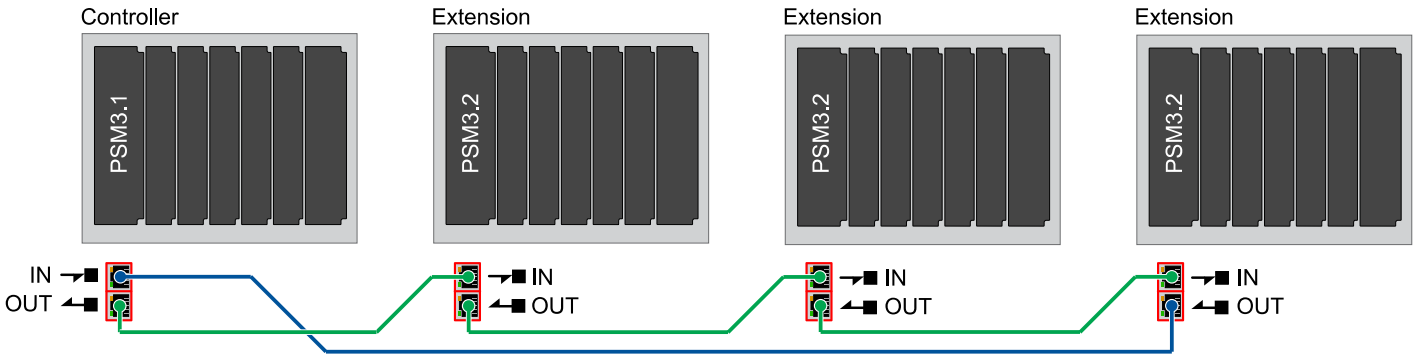
### 4.3.6 Topology examples

EtherCAT communication must be connected only in a chain or ring configuration. Ring configuration provides redundant communication, should one connection be damaged.

#### Chain (single connection)



#### Ring (redundancy connection)



## 4.4 Alternating current module ACM3.1

### 4.4.1 ACM3.1 terminal connections

	Term	Symbol	Name	Type	Default
	1	L1	L1 voltage	Voltage ** 100 to 690 V AC phase-to-phase (nominal)	B-side L1
	2	L2	L2 voltage		B-side L2
	3	L3	L3 voltage		B-side L3
	4	N	N voltage		Optional *
	5	L1	L1 voltage	Voltage ** 100 to 690 V AC phase-to-phase (nominal)	A-side L1
	6	L2	L2 voltage		A-side L2
	7	L3	L3 voltage		A-side L3
	8	N	N voltage		Optional
	9		Current in (Europe: S1; US: ·)	Current 1 or 5 A AC (nominal)	A-side L1
	10				
	11		Current in (Europe: S1; US: ·)	Current 1 or 5 A AC (nominal)	A-side L2
	12				
	13		Current in (Europe: S1; US: ·)	Current 1 or 5 A AC (nominal)	A-side L3
	14				
	15		Current in (Europe: S1; US: ·)	Current 1 or 5 A AC (nominal)	Configurable
	16				

**NOTE** \* The Neutral terminal must only be wired if it is available on both the B-side and the A-side. If neutral is wired on just one side it could cause an error during synchronisation.

\*\* The two sets of voltage measurements must not be swapped around. The controller uses the A-side of voltage measurements together with the L1 to L3 current measurements for a number of calculations. We recommend to fit encoding pins to the voltage measurement terminals.



**DANGER!**



**Do not connect or disconnect a CT with live current present**

The current measurement terminal block must always be screwed onto the module.

Do not connect or disconnect any current transformer (CT) while there is current in the line.

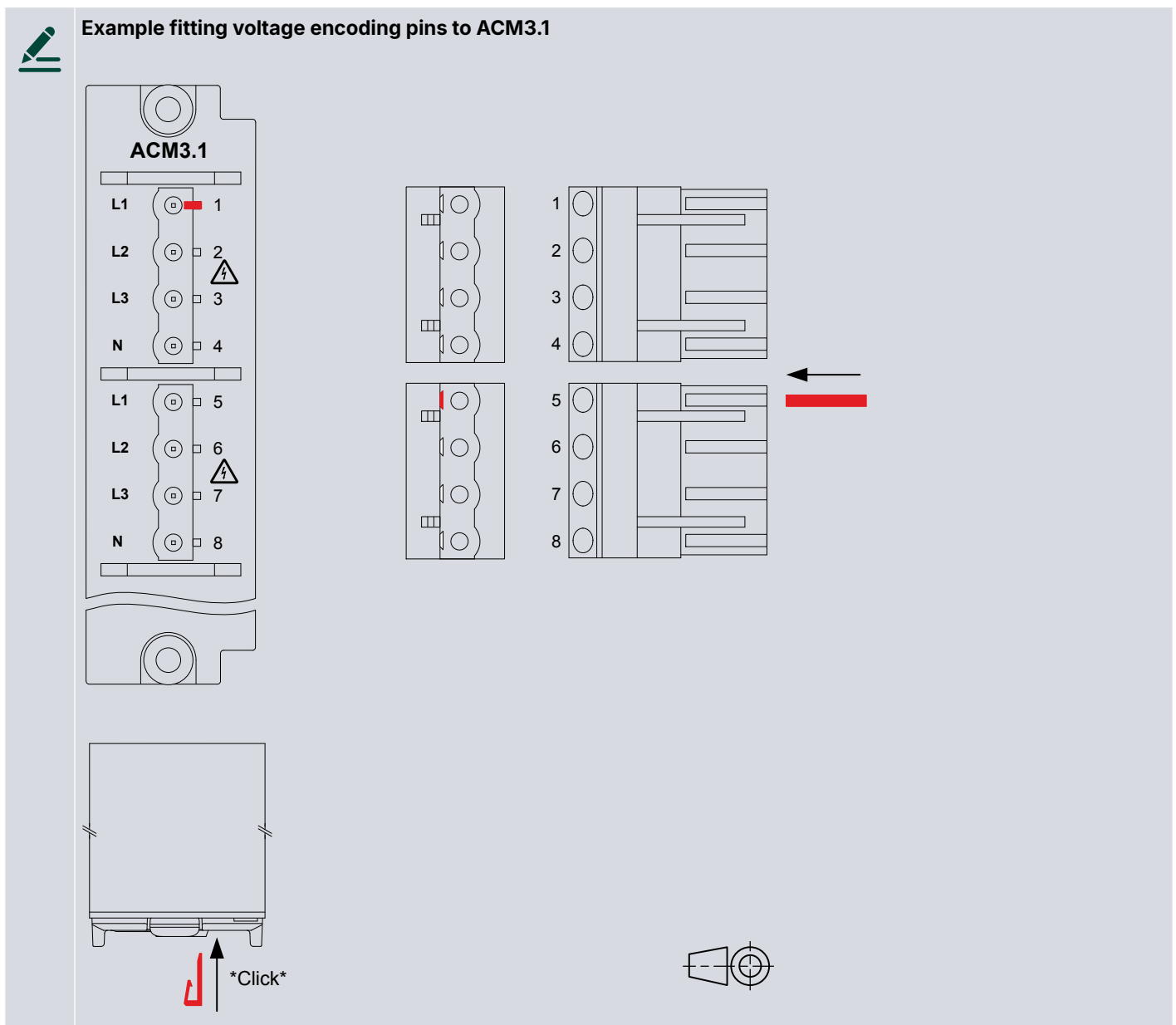
## 4.4.2 Voltage encoding pins for ACM3.1

We strongly recommend the use of encoding pins on the voltage terminals of the ACM3.1.

### Mount encoding pins

For safety reasons the encoding pins should not be reused. Once they are installed it is difficult to remove the pins without damaging the equipment.

1. Identify the terminals where you want to place the encoding pins.
  - a. For example, terminal 1 in terminal group 1-2-3-4 and terminal 5 in terminal group 5-6-7-8 on the ACM3.1 module.
2. Remove the terminal blocks from the module.
3. Place the J-shaped encoding pin in one of the slots next to a terminal pin on the module. The encoding pin is secured when you hear it click into position.
4. Slide the flat encoding pin into the groove on the terminal block of the second terminal group that matches the position of the encoding pin placed in step 3.



## 4.4.3 Voltage measurements wiring

We recommend that you install fuses (2 A rating) on the voltage measurement lines, as close to the busbar as possible, to protect the voltage measurement lines.

#### 4.4.4 Current measurements wiring

The current inputs are galvanically separated.

Mount each current transformer and connect it to the controller terminals so that each measurement current flows through the controller in the correct direction. Incorrect mounting and wiring causes faulty current measurements (see the controller wiring diagrams for the correct mounting direction and wiring).



**DANGER!**

**Do not connect or disconnect a CT with live current present**



If a CT is disconnected when there is current in the line, a high voltage is generated across the secondary of the CT. This can cause arcing, personal injury or death, or damage to the controller.

The current measurement terminal block must always be screwed onto the module. Do not connect or disconnect any current transformer (CT) while there is current in the line.

The current measurement terminal block must always be screwed onto the module. If for some reason the terminal block is unscrewed, secure it using a 0.25 N·m (2.2 lb-in) torque screwdriver with a 3.5 mm (0.14 in) flat-bladed bit.

## 4.5 Differential current module ACM3.2

### 4.5.1 ACM3.2 terminal connections

	Term	Symbol	Name	Type	Default
	1		Current in (Europe: S1; US: ·)	Current * 1 or 5 A AC (nominal)	Consumer side L1
	2		Current out (Europe: S2)		
	3		Current in (Europe: S1; US: ·)	Current * 1 or 5 A AC (nominal)	Consumer side L2
	4		Current out (Europe: S2)		
	5		Current in (Europe: S1; US: ·)	Current * 1 or 5 A AC (nominal)	Consumer side L3
	6		Current out (Europe: S2)		
	7		Current in (Europe: S1; US: ·)	Current * 1 or 5 A AC (nominal)	Neutral side L1
	8		Current out (Europe: S2)		
	9		Current in (Europe: S1; US: ·)	Current * 1 or 5 A AC (nominal)	Neutral side L2
	10		Current out (Europe: S2)		
	11		Current in (Europe: S1; US: ·)	Current * 1 or 5 A AC (nominal)	Neutral side L3
	12		Current out (Europe: S2)		

**NOTE** \* The two sets of current measurements must not be swapped around.



**DANGER!**

**Do not connect or disconnect a CT with live current present**



If a CT is disconnected when there is current in the line, a high voltage is generated across the secondary of the CT. This can cause arcing, personal injury or death, or damage to the controller.

The current measurement terminal block must always be screwed onto the module. Do not connect or disconnect any current transformer (CT) while there is current in the line.

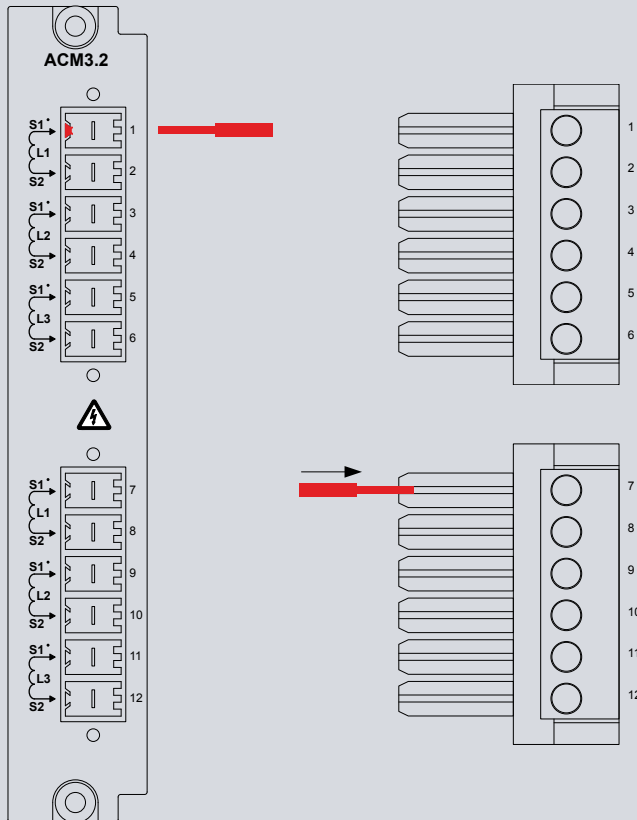
### 4.5.2 Current encoding pins for ACM3.2

We strongly recommend the use of encoding pins on the current terminals of the ACM3.2.



### Example fitting voltage encoding pins to ACM3.2

The encoding pins for the ACM3.2 are not the same as the encoding pins for voltage on the ACM3.1 or other terminals.



### 4.5.3 Current measurements wiring

By default the direction of the current transformers are towards the protected area (as shown in the default wiring). If the direction of the current transformers is not the same as the default direction, then the *Current reference dir.* parameter must be update to be the same as the direction of the installed current transformer.

The current inputs are galvanically separated.

Mount each current transformer and connect it to the controller terminals so that each measurement current flows through the controller in the correct direction. Incorrect mounting and wiring causes faulty current measurements (see the controller wiring diagrams for the correct mounting direction and wiring).



**DANGER!**

#### **Do not connect or disconnect a CT with live current present**



If a CT is disconnected when there is current in the line, a high voltage is generated across the secondary of the CT. This can cause arcing, personal injury or death, or damage to the controller.

The current measurement terminal block must always be screwed onto the module. Do not connect or disconnect any current transformer (CT) while there is current in the line.

The current measurement terminal block must always be screwed onto the module. If for some reason the terminal block is unscrewed, secure it using a 0.25 N·m (2.2 lb·in) torque screwdriver with a 3.5 mm (0.14 in) flat-bladed bit.

## 4.6 Input/output module IOM3.1

### 4.6.1 IOM3.1 terminal connections

	Term	Symbol	Name	Type	Default
	1		Normally open	Relay output (250 V AC or 30 V DC, and 6 A)	Configurable
	2		Common		
	3		Normally closed		
	4		Normally open	Relay output (250 V AC or 30 V DC, and 6 A)	Configurable
	5		Common		
	6		Normally closed		
	7		Normally open	Relay output (250 V AC or 30 V DC, and 6 A)	Configurable
	8		Common		
	9		Normally closed		
	10		Normally open	Relay output (250 V AC or 30 V DC, and 6 A)	Configurable
	11		Common		
	12		Normally closed		
	13		Bi-directional input	Digital input (OFF: 0 to 2 V DC, ON: 8 to 36 V DC, Impedance: 4.7 kΩ)	Configurable
	14		Bi-directional input	Digital input (OFF: 0 to 2 V DC, ON: 8 to 36 V DC, Impedance: 4.7 kΩ)	Configurable
	15		Bi-directional input	Digital input (OFF: 0 to 2 V DC, ON: 8 to 36 V DC, Impedance: 4.7 kΩ)	Configurable
	16		Bi-directional input	Digital input (OFF: 0 to 2 V DC, ON: 8 to 36 V DC, Impedance: 4.7 kΩ)	Configurable
	17		Bi-directional input	Digital input (OFF: 0 to 2 V DC, ON: 8 to 36 V DC, Impedance: 4.7 kΩ)	Configurable
	18		Bi-directional input	Digital input (OFF: 0 to 2 V DC, ON: 8 to 36 V DC, Impedance: 4.7 kΩ)	Configurable
	19		Bi-directional input	Digital input (OFF: 0 to 2 V DC, ON: 8 to 36 V DC, Impedance: 4.7 kΩ)	Configurable
	20		Bi-directional input	Digital input (OFF: 0 to 2 V DC, ON: 8 to 36 V DC, Impedance: 4.7 kΩ)	Configurable
	21		Bi-directional input	Digital input (OFF: 0 to 2 V DC, ON: 8 to 36 V DC, Impedance: 4.7 kΩ)	Configurable
	22		Bi-directional input	Digital input (OFF: 0 to 2 V DC, ON: 8 to 36 V DC, Impedance: 4.7 kΩ)	Configurable
	23	COM	Common	Digital input	

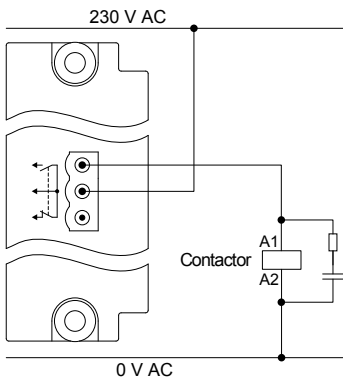
### 4.6.2 Relay output wiring (changeover)

This changeover relay has three terminals: normally closed, common and normally open. You can connect wiring to:

- All three terminals
- Common and normally open terminals
- Common and normally closed terminals

## Connection to Normally open and common terminals

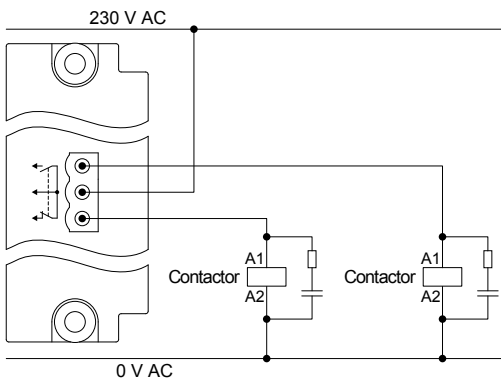
Relay output connected to a 230 V AC contactor. You can swap the terminal connections around without affecting the performance.



Similarly, you can connect equipment to the normally closed terminal and common.

## Connection to all three terminals

For this configuration, current flows through the equipment connected to the normally closed terminal when the relay is de-energised. The current flows through the equipment connected to the normally open terminal when the relay is energised.



For 230 V AC contactors, we strongly recommend that you use an RC snubber for noise suppression across the contactor.

### 4.6.3 Digital input wiring

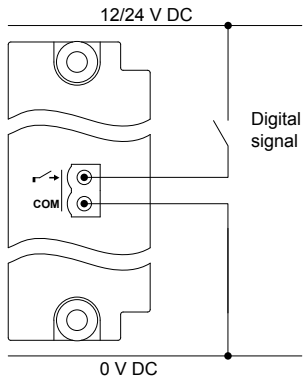
The digital inputs are bi-directional, so you can swap the terminal connections around without affecting the performance..

However, all the digital inputs in a group share a common terminal. The digital input common for a module may be either low (connected to 0 V), or high (connected to 12 or 24 V):

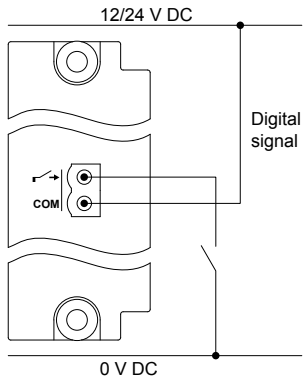
- If common is low: All the digital input signals connected to the group must be high (connected to 12 or 24 V).
- If common is high: All the digital input signals connected to the group must be low (connected to 0 V).

The digital input common is not used as the common for any of the other terminals on the same hardware module. The digital input common is also not affected by the digital input commons on other hardware modules.

### Digital input wiring (common = 0 V)



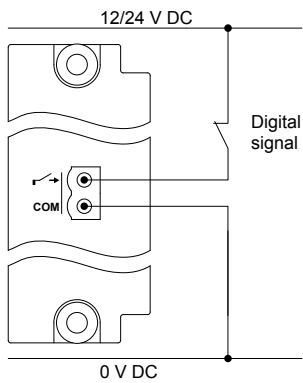
### Digital input wiring (common = 12 or 24 V)



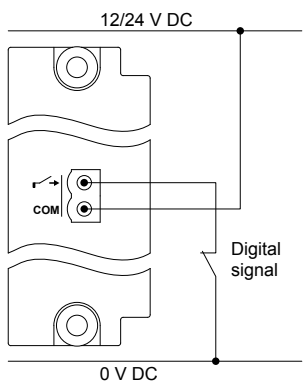
### Safety function wiring

Safety functions, for example, *Emergency stop*, require a normally closed digital signal to be wired to the controller.

### Digital input wiring for safety functions (common = 0 V)



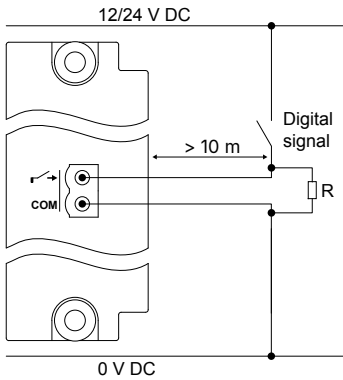
### Digital input wiring for safety functions (common = 12 or 24 V)



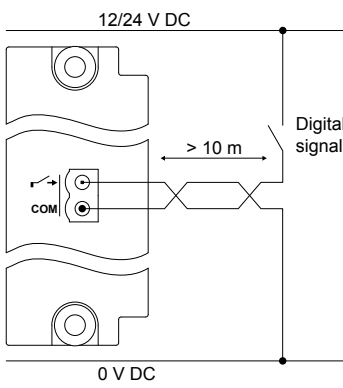
## Compliance with EN60255-26

If the wire to an open contact is over 10 m long, then additional measures are required for compliance with EN60255-26. You can use a 1 k $\Omega$  resistor to common, or you can use a twisted or shielded wire to the open contact.

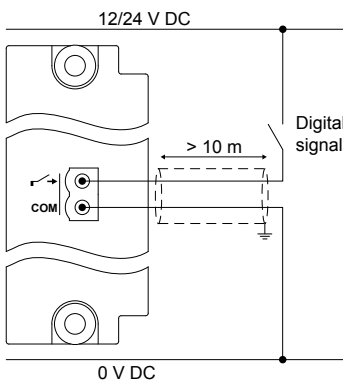
### 1 k $\Omega$ resistor to common for compliance with EN60255-26



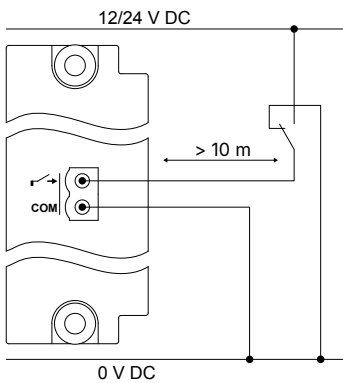
### Twisted wire for compliance with EN60255-26



### Shielded wire for compliance with EN60255-26



### Closed contact for compliance with EN60255-26



## 4.7 Input/output module IOM3.2

### 4.7.1 IOM3.2 terminal connections

#### IOM3.2 terminals 1 to 16

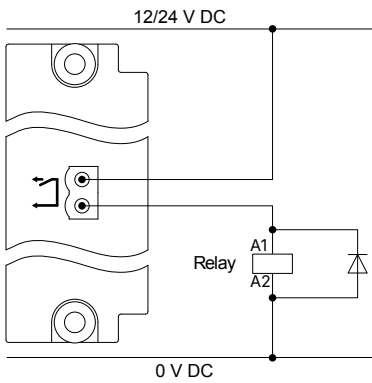
	Term	Symbol	Name	Type	Default
	1		Normally open	Relay output (30 V DC and 6 A)	Configurable
	2		Common		
	3		Normally open	Relay output (30 V DC and 6 A)	Configurable
	4		Common		
	5		Normally open	Relay output (30 V DC and 6 A)	Configurable
	6		Common		
	7		Normally open	Relay output (30 V DC and 6 A)	Configurable
	8		Common		
	9		Analogue output	Analogue current output (-25 to 25 mA DC) Analogue voltage output (-10 to 10 V DC) Analogue PWM output (1 to 2500 Hz)	Configurable
	10		Common		
	11		Analogue output		
	12		Common	Analogue current output (-25 to 25 mA DC) Analogue voltage output (-10 to 10 V DC) Analogue PWM output (1 to 2500 Hz)	Configurable
	13		Analogue output		
	14		Common		
	15		Analogue output	Analogue current output (-25 to 25 mA DC) Analogue voltage output (-10 to 10 V DC)	Configurable
	16		Common		
17					
18					
19					
20					
21					
22					
23					
24					
25					
26					
27					
28					
29					

## IOM3.2 terminals 17 to 29

	Term	Symbol	Name	Type	Default	
	17		Bi-directional input	Digital input (OFF: -2 to 2 V DC, ON: -36 to -8 V DC or 8 to 36 V DC, Impedance: 3.9 kΩ)	Configurable	
	18		Bi-directional input	Digital input (OFF: -2 to 2 V DC, ON: -36 to -8 V DC or 8 to 36 V DC, Impedance: 3.9 kΩ)	Configurable	
	19		Bi-directional input	Digital input (OFF: -2 to 2 V DC, ON: -36 to -8 V DC or 8 to 36 V DC, Impedance: 3.9 kΩ)	Configurable	
	20		Bi-directional input	Digital input (OFF: -2 to 2 V DC, ON: -36 to -8 V DC or 8 to 36 V DC, Impedance: 3.9 kΩ)	Configurable	
	21	COM		Common		-
	22	$i^V_R \rightarrow$		Analogue input	Current input (0 to 20 mA or 4 to 20 mA) Voltage input (-10 to 10 V DC or 0 to 10 V DC) RMI 1 or 2 wire (0 to 4.5 kΩ) Pt100 (-200 to 850 °C) Pt1000 (-200 to 850 °C)	Configurable
	23		Common	Thermocouple (E: -200 to 1000 °C, J: -210 to 1200 °C, K: -200 to 1372 °C, N: -200 to 1300 °C, R: -50 to 1768 °C, S: -50 to 1768 °C, T: -200 to 400 °C)		
	24	$i^V_R \rightarrow$		Analogue input	Current input (0 to 20 mA or 4 to 20 mA) Voltage input (-10 to 10 V DC or 0 to 10 V DC) RMI 1 or 2 wire (0 to 4.5 kΩ) Pt100 (-200 to 850 °C) Pt1000 (-200 to 850 °C)	Configurable
	25		Common	Thermocouple (E: -200 to 1000 °C, J: -210 to 1200 °C, K: -200 to 1372 °C, N: -200 to 1300 °C, R: -50 to 1768 °C, S: -50 to 1768 °C, T: -200 to 400 °C)		
	26	$i^V_R \rightarrow$		Analogue input	Current input (0 to 20 mA or 4 to 20 mA) Voltage input (-10 to 10 V DC or 0 to 10 V DC) RMI 1 or 2 wire (0 to 4.5 kΩ) Pt100 (-200 to 850 °C) Pt1000 (-200 to 850 °C)	Configurable
	27		Common	Thermocouple (E: -200 to 1000 °C, J: -210 to 1200 °C, K: -200 to 1372 °C, N: -200 to 1300 °C, R: -50 to 1768 °C, S: -50 to 1768 °C, T: -200 to 400 °C)		
	28	$i^V_R \rightarrow$		Analogue input	Current input (0 to 20 mA or 4 to 20 mA) Voltage input (-10 to 10 V DC or 0 to 10 V DC) RMI 1 or 2 wire (0 to 4.5 kΩ) Pt100 (-200 to 850 °C) Pt1000 (-200 to 850 °C)	Configurable
	29		Common	Thermocouple (E: -200 to 1000 °C, J: -210 to 1200 °C, K: -200 to 1372 °C, N: -200 to 1300 °C, R: -50 to 1768 °C, S: -50 to 1768 °C, T: -200 to 400 °C)		

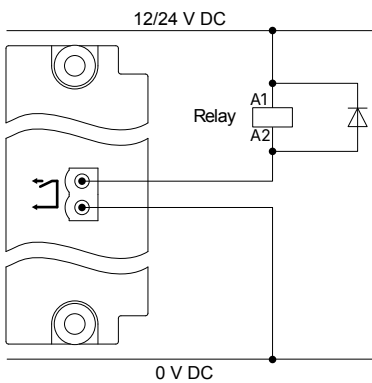
### 4.7.2 Relay output wiring


The diagram shows the connection of the relay output to an external relay. There is no voltage on the external relay when the controller relay is open.



Use a diode size as recommended by the relay supplier.

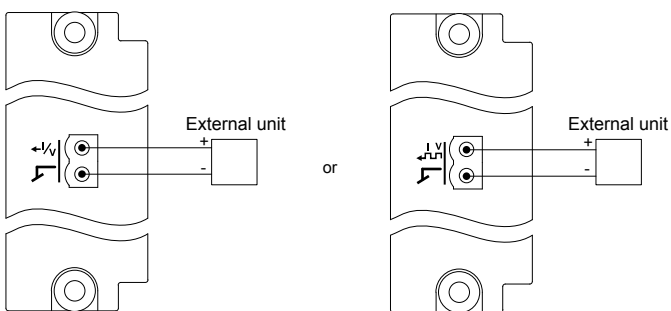
You can swap the terminal connections around without affecting the performance.



Install a freewheeling diode (  ) to prevent a sudden voltage spike across the inductive load when the voltage source is removed.

### 4.7.3 Analogue multifunctional current or voltage outputs wiring

The diagram below shows the connection of an external controller to the DEIF controller's analogue current or voltage output. The I/O configuration determines whether the output is current or voltage.



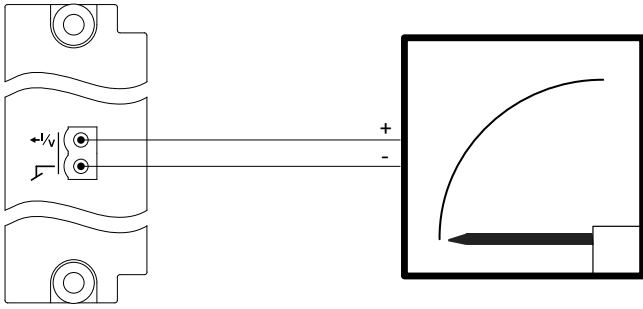
## NOTICE

### Terminal damage

These outputs are active outputs. Do not connect an external power supply to these terminals. Connecting an external power supply may damage the terminals.

### Using an analogue output with an external instrument

The analogue output can be connected directly to a 4 to 20 mA external instrument:



DEIF recommends using instruments from the DEIF DQ moving coil instrument series. See <http://www.deif.com> for more information.

#### 4.7.4 Digital input wiring

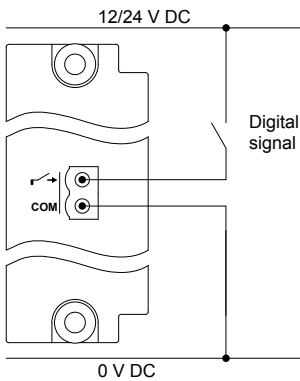
The digital inputs are bi-directional, so you can swap the terminal connections around without affecting the performance..

However, all the digital inputs in a group share a common terminal. The digital input common for a module may be either low (connected to 0 V), or high (connected to 12 or 24 V):

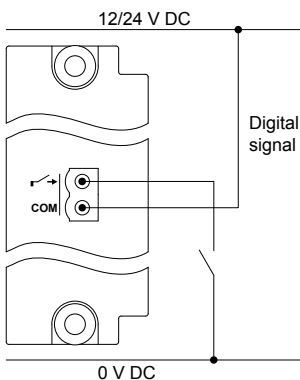
- If common is low: All the digital input signals connected to the group must be high (connected to 12 or 24 V).
- If common is high: All the digital input signals connected to the group must be low (connected to 0 V).

The digital input common is not used as the common for any of the other terminals on the same hardware module. The digital input common is also not affected by the digital input commons on other hardware modules.

##### Digital input wiring (common = 0 V)



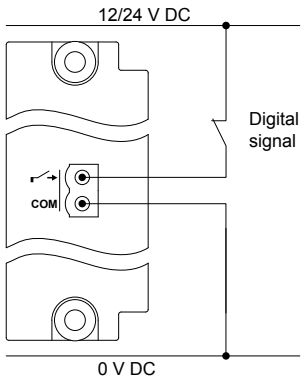
##### Digital input wiring (common = 12 or 24 V)



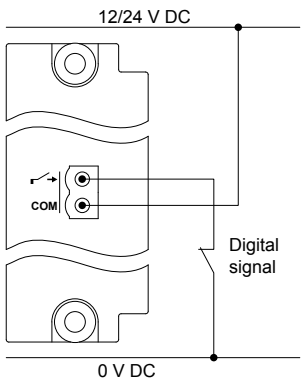
##### Safety function wiring

Safety functions, for example, *Emergency stop*, require a normally closed digital signal to be wired to the controller.

### Digital input wiring for safety functions (common = 0 V)



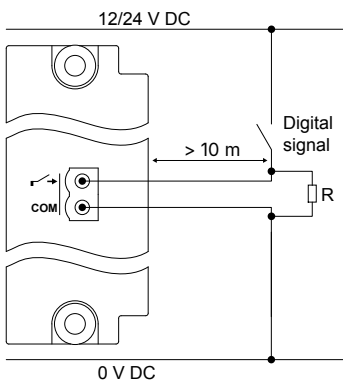
### Digital input wiring for safety functions (common = 12 or 24 V)



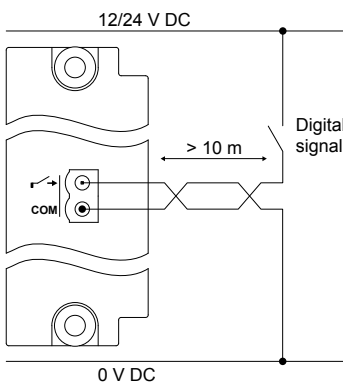
### Compliance with EN60255-26

If the wire to an open contact is over 10 m long, then additional measures are required for compliance with EN60255-26. You can use a 1 k $\Omega$  resistor to common, or you can use a twisted or shielded wire to the open contact.

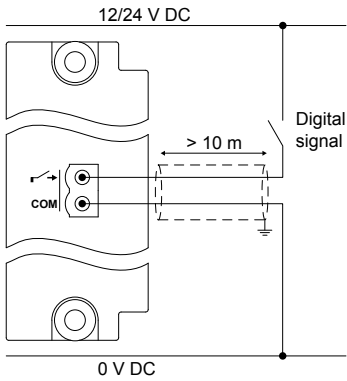
#### 1 k $\Omega$ resistor to common for compliance with EN60255-26



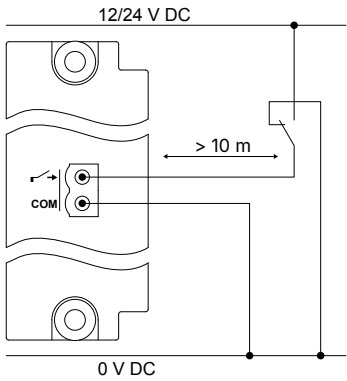
#### Twisted wire for compliance with EN60255-26



## Shielded wire for compliance with EN60255-26



## Closed contact for compliance with EN60255-26



### 4.7.5 Analogue multifunctional inputs wiring

The I/O configuration determines whether the input is current or resistance. For resistance, the I/O configuration also determines the type of resistance input.

#### NOTICE

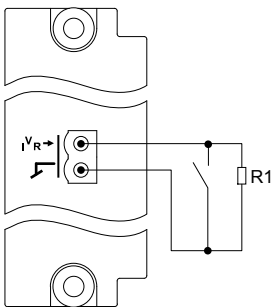
##### Before connecting external transmitter

Configure the terminals correctly (that is, for current or for voltage) before connecting the external transmitter.

#### Digital inputs with wire break detection

Wire-break detection with maximum resistance for ON detection: 100  $\Omega$  to 400  $\Omega$ .

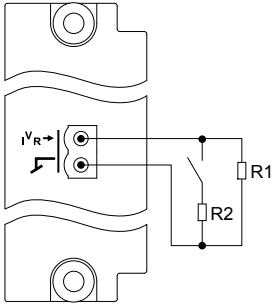
#### Connection of a dry contact with cable supervision



Requirements:

- The maximum resistance for the circuit and resistor (R1) is 330  $\Omega$ .
- R1 must be connected to the switch, and not to the controller terminals.

## Connection of a dry contact with cable supervision, and short circuit detection



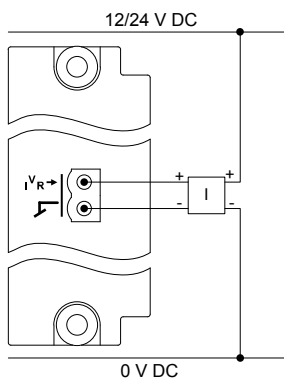
### Requirements:

- The maximum resistance for the circuit and resistor (R1) is 330  $\Omega$ .
- The resistance of R2 must be less than R1.
- R1 must be connected to the switch, and not to the controller terminals.

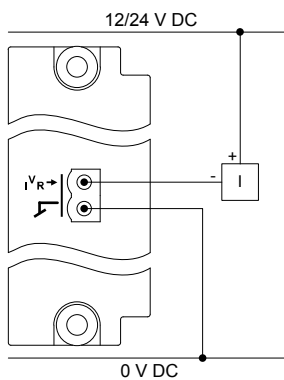
## Current input

The current input may be either active or passive, and a combination of active and passive inputs may be used.

### Connection of an active transducer

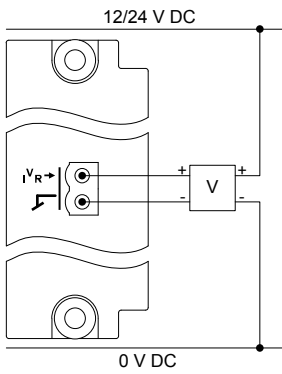


### Connection of a passive transducer



## Voltage input

The following diagram shows the connection for voltage input.

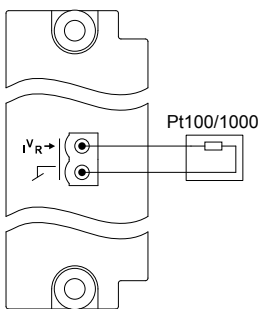


### Resistance input

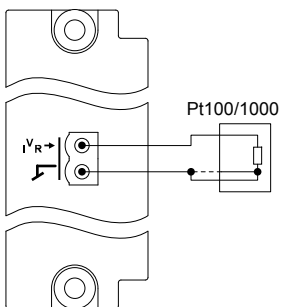
The resistance inputs are always passive inputs. The controller sends a small current through the external equipment and measures the resistance.

**NOTE** There is no software compensation for the wire length to the resistance input.

### Connection of a 2-wire Pt100/1000 sensor

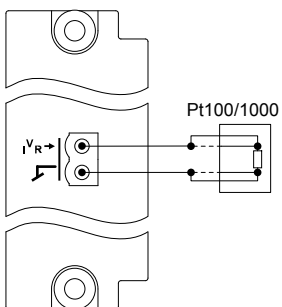


### Connection of a 3-wire Pt100/1000 sensor



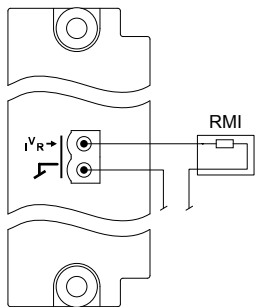
You do not have to connect the third wire (shown by the dashed line). If you want to connect the third wire, connect it to the common, as shown in the diagram.

### Connection of a 4-wire Pt100/1000 sensor

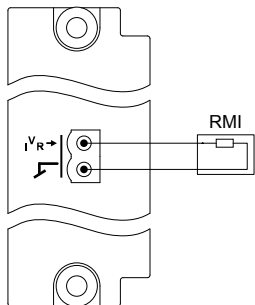


You do not have to connect the third and fourth wires (shown by the dashed lines). If you want to connect them, connect them as shown in the diagram.

### Connection of a 1-wire resistance measurement input (RMI)



### Connection of a 2-wire resistance measurement input (RMI)



## 4.8 Input/output module IOM3.3

### 4.8.1 IOM3.3 terminal connections

**Table 4.3** IOM3.3 Analogue multifunctional inputs

	Term	Symbol	Name	Type	Default
	1	A	Analogue input	Current input 0 to 20 mA or 4 to 20 mA	Configurable
	2	→ B			
	3	C			
	4	A	Analogue input	Voltage input -10 to 10 V DC or 0 to 10 V DC	Configurable
	5	→ B			
	6	C			
	7	A	Analogue input	RMI 2 or 3 wire 0 to 4.5 kΩ ±1 Ω	Configurable
	8	→ B			
	9	C			
	10	A	Analogue input	RMI 1 wire 0 to 4.5 kΩ ±2 Ω	Configurable
	11	→ B			
	12	C			
	13	A	Analogue input	Pt100 -200 to 850 °C	Configurable
	14	→ B			
	15	C			
	16	A	Analogue input	Pt1000 -200 to 850 °C	Configurable
	17	→ B			
	18	C			
	19	A	Analogue input	Thermocouple E: -200 to 1000 °C J: -210 to 1200 °C K: -200 to 1372 °C N: -200 to 1300 °C R: -50 to 1768 °C S: -50 to 1768 °C T: -200 to 400 °C	Configurable
	20	→ B			
	21	C			
	22	A	Analogue input		Configurable
	23	→ B			
	24	C			
	25	A	Analogue input		Configurable
	26	→ B			
	27	C			
	28	A	Analogue input		Configurable
	29	→ B			
	30	C			

### 4.8.2 Analogue multifunctional inputs

The I/O configuration determines whether the input is current or resistance. For resistance, the I/O configuration also determines the type of resistance input.

## NOTICE

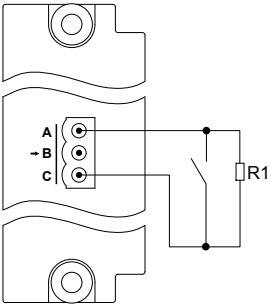
### Before connecting the external transmitter

Configure the terminals correctly (that is, for current or for voltage) before connecting the external transmitter.

### 4.8.3 Digital inputs wiring with wire break detection

Wire-break detection with maximum resistance for ON detection: 100  $\Omega$  to 400  $\Omega$ .

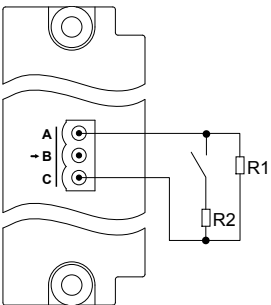
**Figure 4.1** Connection of a dry contact with cable supervision



Requirements:

- The maximum resistance for the circuit and resistor (R1) is 330  $\Omega$ .
- R1 must be connected to the switch, and not to the controller terminals.

**Figure 4.2** Connection of a dry contact with cable supervision, and short circuit detection



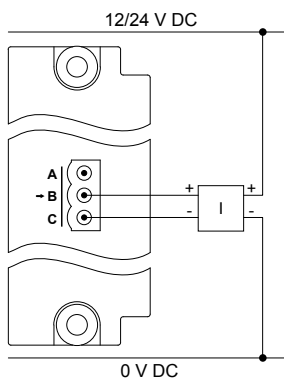
Requirements:

- The maximum resistance for the circuit and resistor (R1) is 330  $\Omega$ .
- The resistance of R2 must be less than R1.
- R1 must be connected to the switch, and not to the controller terminals.

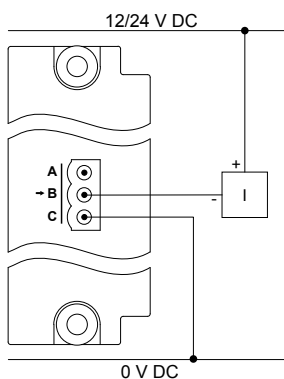
### 4.8.4 Analogue current inputs wiring

The current input may be either active or passive, and a combination of active and passive inputs may be used.

**Figure 4.3** Connection of an active transducer

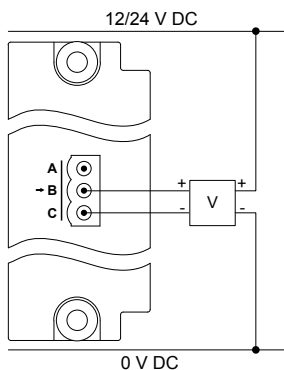


**Figure 4.4** Connection of a passive transducer



### 4.8.5 Analogue voltage inputs wiring

The following diagram shows the connection for voltage input.

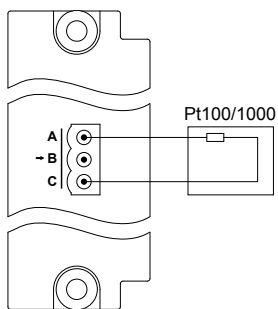


### 4.8.6 Analogue resistance inputs wiring

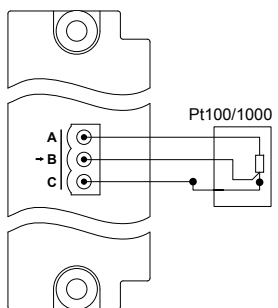
The resistance inputs are always passive inputs. The controller sends a small current through the external equipment and measures the resistance.

**NOTE** There is no software compensation for the wire length to the resistance input.

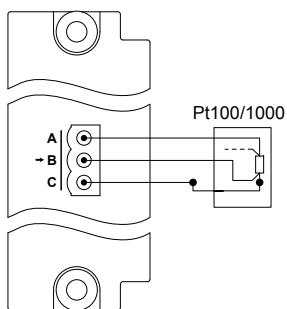
**Figure 4.5** Connection of a 2-wire Pt100/1000 sensor



**Figure 4.6** Connection of a 3-wire Pt100/1000 sensor

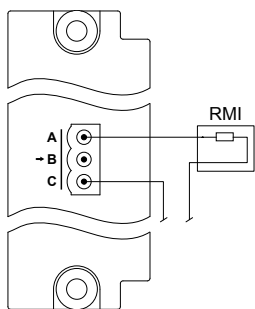


**Figure 4.7** Connection of a 4-wire Pt100/1000 sensor

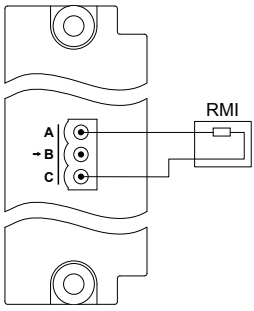


You do not have to connect the fourth wire (shown by the dashed line).

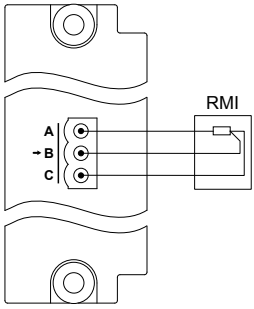
**Figure 4.8** Connection of a 1-wire resistance measurement input (RMI)



**Figure 4.9** Connection of a 2-wire resistance measurement input (RMI)

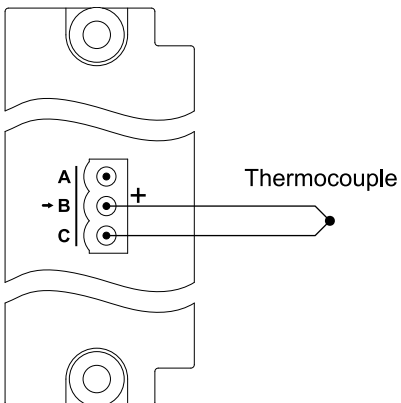


**Figure 4.10** Connection of a 3-wire resistance measurement input (RMI)



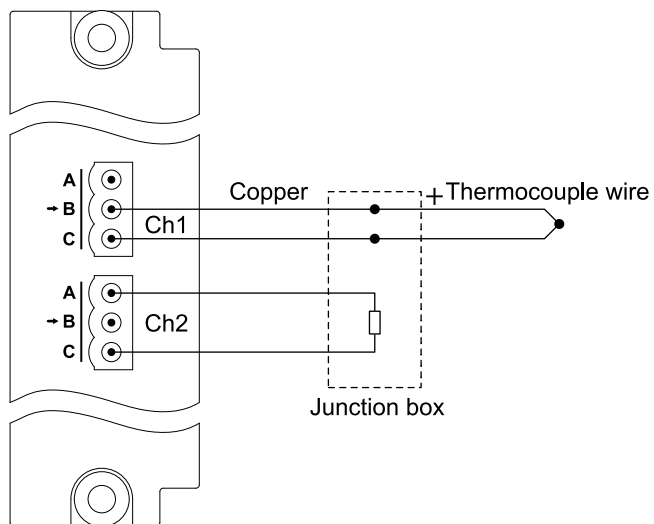
### 4.8.7 Analogue thermocouple inputs wiring

**Figure 4.11** Connection of thermocouple with internal compensation input



Compensation occurs in the IOM3.3 module.

**Figure 4.12** Connection of thermocouple with external compensation input



The cold junction compensation can be wired to any input on the controller that can measure a temperature sensor.

## 4.9 Input/output module IOM3.4

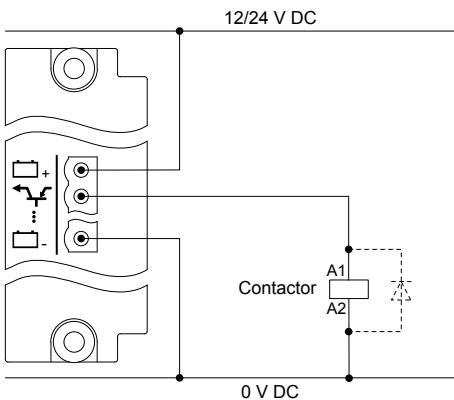
### 4.9.1 IOM3.4 terminal connections

	Term.	Symbol	Name	Type	Default
	1		Positive supply	Positive supply for digital output terminals 2 to 13 (12 or 24 V DC) (nominal), maximum 36 V DC	Positive supply
	2		Digital output	<b>Digital outputs:</b>  <b>Maximum current:</b> < 55 °C: 250 mA (per output) <b>Leak current:</b> Typical 1 µA, maximum 100 µA <b>Saturation voltage:</b> Maximum 0.5 V <b>Non-replaceable:</b> 4 A fuse <b>Voltage withstand:</b> ±36 V DC	Configurable
	3		Digital output		Configurable
	4		Digital output		Configurable
	5		Digital output		Configurable
	6		Digital output		Configurable
	7		Digital output		Configurable
	8		Digital output		Configurable
	9		Digital output		Configurable
	10		Digital output		Configurable
	11		Digital output		Configurable
	12		Digital output		Configurable
	13		Digital output		Configurable
	14		Common		Common for digital output terminals 2 to 13
	15		Bi-directional input	<b>Digital inputs:</b>  <b>OFF:</b> 0 to 2 V DC <b>ON:</b> 8 to 36 V DC <b>Impedance:</b> 4.7 kΩ	Configurable
	16		Bi-directional input		Configurable
	17		Bi-directional input		Configurable
	18		Bi-directional input		Configurable
	19		Bi-directional input		Configurable
	20		Bi-directional input		Configurable
	21		Bi-directional input		Configurable
	22		Bi-directional input		Configurable
	23	COM	Common	Common for digital input terminals 15 to 22	

	Term.	Symbol	Name	Type	Default
	24		Bi-directional input	<b>Digital inputs:</b> <b>OFF:</b> 0 to 2 V DC <b>ON:</b> 8 to 36 V DC <b>Impedance:</b> 4.7 kΩ	Configurable
	25		Bi-directional input		Configurable
	26		Bi-directional input		Configurable
	27		Bi-directional input		Configurable
	28		Bi-directional input		Configurable
	29		Bi-directional input		Configurable
	30		Bi-directional input		Configurable
	31		Bi-directional input		Configurable
	32	COM	Common		Common for digital input terminals 24 to 31

## 4.9.2 Digital output wiring

Each transistor has a normally open terminal (). The transistor group has a positive supply terminal (+), and a common (-). The following diagram shows the connection of the transistor output to an external contactor.



**NOTE** You can install a diode () to reduce electromagnetic interference.

## 4.9.3 Digital input wiring

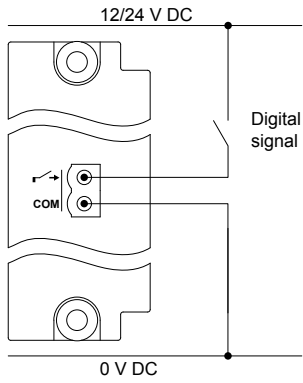
The digital inputs are bi-directional, so you can swap the terminal connections around without affecting the performance..

However, all the digital inputs in a group share a common terminal. The digital input common for a module may be either low (connected to 0 V), or high (connected to 12 or 24 V):

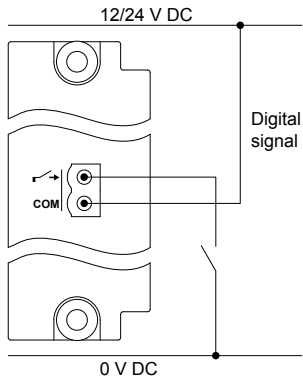
- If common is low: All the digital input signals connected to the group must be high (connected to 12 or 24 V).
- If common is high: All the digital input signals connected to the group must be low (connected to 0 V).

The digital input common is not used as the common for any of the other terminals on the same hardware module. The digital input common is also not affected by the digital input commons on other hardware modules.

### Digital input wiring (common = 0 V)



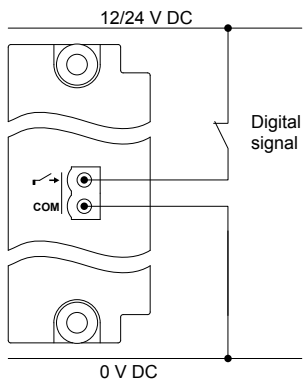
### Digital input wiring (common = 12 or 24 V)



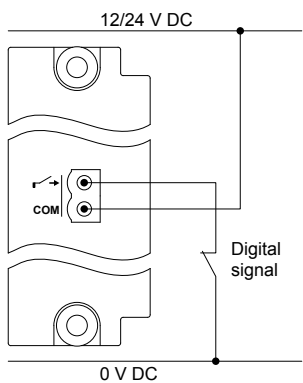
### Safety function wiring

Safety functions, for example, *Emergency stop*, require a normally closed digital signal to be wired to the controller.

### Digital input wiring for safety functions (common = 0 V)



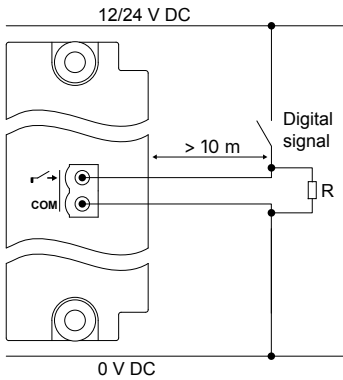
### Digital input wiring for safety functions (common = 12 or 24 V)



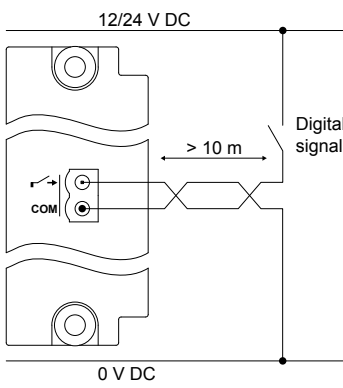
## Compliance with EN60255-26

If the wire to an open contact is over 10 m long, then additional measures are required for compliance with EN60255-26. You can use a 1 k $\Omega$  resistor to common, or you can use a twisted or shielded wire to the open contact.

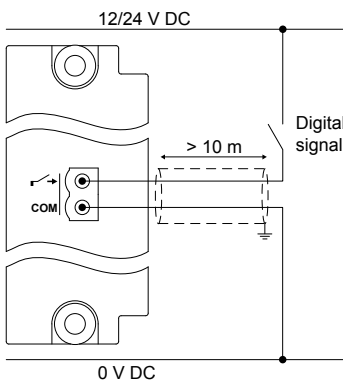
### 1 k $\Omega$ resistor to common for compliance with EN60255-26



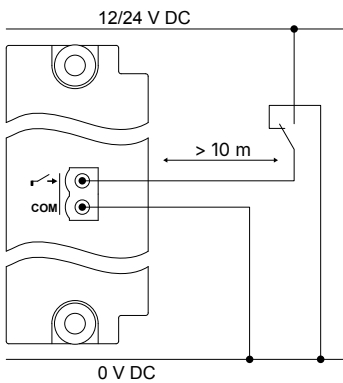
### Twisted wire for compliance with EN60255-26



### Shielded wire for compliance with EN60255-26



### Closed contact for compliance with EN60255-26



## 4.10 Engine interface module EIM3.1

### 4.10.1 EIM3.1 terminal connections

	Term	Symbol	Name	Type	Default	
<p>The diagram shows a vertical terminal block with 22 terminals. Terminal 1 is labeled 'F/G' and has a ground symbol. Terminal 2 is labeled '1' and has a positive terminal symbol. Terminal 3 is labeled '2' and has a negative terminal symbol. Terminals 3, 4, 5, 6, 7, 8, 9, and 10 are grouped as relay outputs, with symbols for normally open and common contacts. Terminals 11, 12, 13, and 14 are grouped as digital inputs, with symbols for bi-directional inputs. Terminal 15 is labeled 'COM'. Terminals 16, 17, and 18 are grouped as MPU/W inputs, with symbols for MPU input and W input. Terminals 19, 20, and 21 are grouped as analogue RMI inputs, with symbols for R/I inputs. Terminal 22 is labeled 'COM'.</p>	F/G		F/G	Ground	Frame ground	
	1		+	12 or 24 V DC (nominal) *	Power supply *	
	2		-	0 V DC		
	3			Normally open	<b>Relay output:</b> 30 V DC and 6 A	Configurable
	4			Common		
	5			Normally open	<b>Relay output:</b> 30 V DC and 6 A	Configurable
	6			Common		
	7			Normally open	<b>Relay output:</b> 30 V DC and 6 A	Configurable
	8			Common		
	9			Normally open	<b>Relay output with wire break detection:</b> 30 V DC and 6 A	Configurable
	10			Common		
	11			Bi-directional input		Configurable
	12			Bi-directional input	<b>Digital inputs:</b>  <b>OFF:</b> 0 to 2 V DC <b>ON:</b> 8 to 36 V DC <b>Impedance:</b> 4.7 kΩ	Configurable
	13			Bi-directional input		Configurable
	14			Bi-directional input		Configurable
	15	COM		Common		Common for digital input terminals 11 to 14
	16			MPU input	MPU input (Voltage: 2 to 70 V AC peak, Frequency: 2 to 20,000 Hz)	Magnetic pickup
	17	COM		Common	Common for MPU or W input	
	18	W		W input	W input (Voltage: 8 to 36 V AC, Frequency: 2 to 20,000 Hz)	Generator tacho or NPN/PNP sensor
	19	R/I		Analogue RMI input	<b>Analogue current or resistance measurement input (RMI):</b>  <b>Current input:</b> 0 to 20 mA, or 4 to 20 mA <b>Pt100/1000:</b> -40 to 250 °C <b>Resistance measurement:</b> 0 to 2.5 kΩ <b>Digital input (dry contact with cable supervision):</b> maximum 330 Ω for ON detection <b>Minimum current rating for connected relays:</b> 2.5 mA	Configurable
	20	R/I		Analogue RMI input		Configurable
	21	R/I		Analogue RMI input		Configurable
22	COM		Common	Analogue input common		

### 4.10.2 Frame ground wiring

Create a protective earth:

1. Connect the frame ground terminal to the protective earth connection.
2. Connect the frame ground terminal to the cabinet.
3. Connect the rack to the cabinet.

The frame ground is connected to the power supply terminals through transient voltage suppression diodes (transorbs). In order to protect the frame ground and power supply, max. 36 V is allowed between the frame ground and the power supply terminals.

### 4.10.3 Power supply wiring

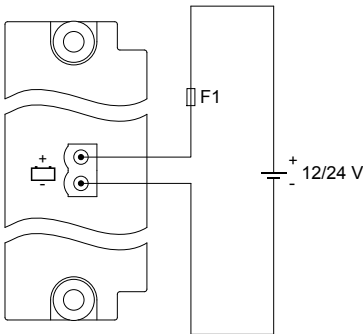
Connect the power supply (+) to the 12 or 24 V DC power supply, and the power supply (-) to the 0 V DC power supply.

#### NOTICE

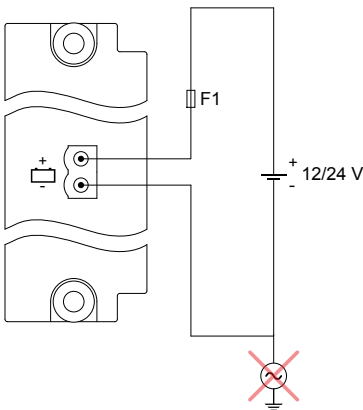
##### Negative power supply terminal

Do not wire the negative power supply terminal of the modules with independent power supplies (for example, PSM 3.1) to the single-phase ground. If the voltage between the power supply terminals and frame ground exceeds 36 V, the power supply terminals and the frame ground terminal will be damaged.

#### Recommended wiring for the power supply



#### Incorrect wiring of the power supply



If the EIM power supply fails or is not connected, the PSM will supply power to the EIM.

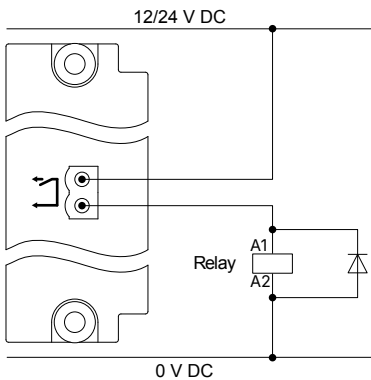
If the PSM power supply fails, the EIM will run on its independent power supply. However, the EIM will not supply power to the PSM.

The equipment does not contain a backup power supply. The power supply source must therefore include the necessary power backup.

Maritime class societies require an independent power supply for the EIM. The EIM must therefore not be connected to the same power supply source as the PSM.

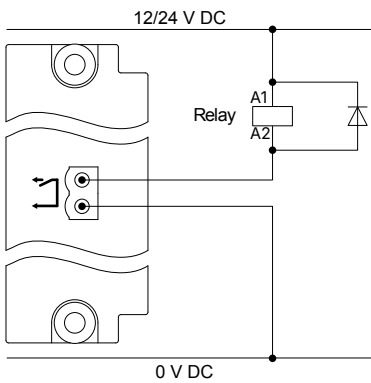
## 4.10.4 Relay output wiring


The diagram shows the connection of the relay output to an external relay. There is no voltage on the external relay when the controller relay is open.



Use a diode size as recommended by the relay supplier.

You can swap the terminal connections around without affecting the performance.

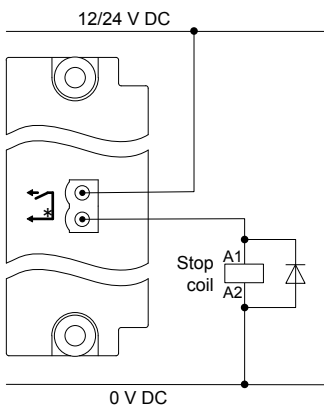


Install a freewheeling diode (  ) to prevent a sudden voltage spike across the inductive load when the voltage source is removed.

## 4.10.5 Relay output with wire break detection


The diagram below shows an example of the wiring for this output.

**Figure 4.13** Example: Stop coil relay with wire break detection



Do not connect the terminals to an alternating current supply. Alternating current will destroy the wire break detection.

The relay with wire break detection uses a small, constant current for wire break detection. This current can activate small relays, and cannot be turned off.

Remember to install the freewheeling diode (  ). This diode prevents a sudden voltage spike across the inductive load when the voltage source is removed.

### Checking the relay size

The wire break detection current leak does not activate the relay if this formula is true:

$$V_{\text{release}} > (V_{\text{supply}} - 4.5 \text{ V}) / (3900 \Omega + R_{\text{coil}}) \times R_{\text{coil}}$$

$V_{\text{release}}$  The release voltage for the relay (see the relay's data sheet).

$V_{\text{supply}}$  The supply voltage that the relay is connected to (12 or 24 V).

$R_{\text{coil}}$  The relay coil resistance (see the relay's data sheet).

This formula does not include a safety factor.

If the calculation shows that the relay is too small, use a relay with a higher release voltage and/or a smaller coil resistance.



#### Relay coil resistance calculation example 1

For a 24 V supply, a relay with a 7.5 V release voltage and a 630  $\Omega$  coil is proposed.

The right side of the equation is then  $(24 \text{ V} - 4.5 \text{ V}) / (3900 \Omega + 630 \Omega) \times 630 \Omega = 2.7 \text{ V}$ .

The release voltage (7.5 V) is more than 2.7 V. The wire break detection current leak will not activate this relay.



#### Relay coil resistance calculation example 2

For a 12 V supply, a relay with a 0.6 V release voltage and an 848  $\Omega$  coil is proposed.

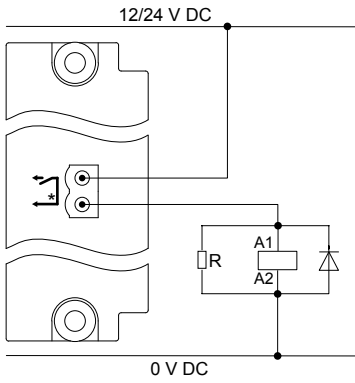
The right side of the equation is then  $(12 \text{ V} - 4.5 \text{ V}) / (3900 \Omega + 848 \Omega) \times 848 \Omega = 1.3 \text{ V}$ .

The release voltage (0.6 V) is less than 1.3 V. The wire break detection current leak will activate this relay. Use a bigger relay, or use an external resistor to prevent relay activation.

### Using an external resistor to prevent relay activation

If you do not need to detect a wire break in the stop coil, you can install an external resistor to stop the wire break detection current leak from activating the relay.

**Figure 4.14** Wiring example for external resistor to stop the wire break current leak from activating the relay



Use the following formula to calculate the maximum resistor size (in ohms):

$$R_{\text{resistor}} < R_{\text{coil}} \times V_{\text{release}} \times (2 \times R_{\text{coil}} + 7800) / (2 \times R_{\text{coil}} \times V_{\text{supply}} - 9 \times R_{\text{coil}} - 7800 \times V_{\text{release}} - 2 \times R_{\text{coil}} \times V_{\text{release}})$$

This formula does not include a safety factor.

If you get a negative result on the right side, then you do not need a resistor.



#### External resistor size calculation example

For a 24 V supply, a relay with a 1.2 V release voltage and a 3390 Ω coil is proposed. The wire break detection current will activate this relay, and so an external resistor is required.

The external resistor must have less resistance than:

$$3390 \times 1.2 \times (2 \times 3390 + 7800) / (2 \times 3390 \times 24 - 9 \times 3390 - 7800 \times 1.2 - 2 \times 3390 \times 1.2) = 517 \Omega$$

Use a 470 Ω resistor to stop the wire break detection current leak from activating this relay.

Use an external resistor to prevent wire break detection in the stop coil.

### 4.10.6 Digital input wiring

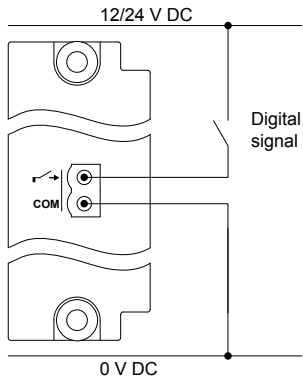
The digital inputs are bi-directional, so you can swap the terminal connections around without affecting the performance..

However, all the digital inputs in a group share a common terminal. The digital input common for a module may be either low (connected to 0 V), or high (connected to 12 or 24 V):

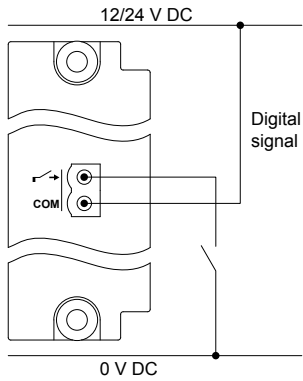
- If common is low: All the digital input signals connected to the group must be high (connected to 12 or 24 V).
- If common is high: All the digital input signals connected to the group must be low (connected to 0 V).

The digital input common is not used as the common for any of the other terminals on the same hardware module. The digital input common is also not affected by the digital input commons on other hardware modules.

### Digital input wiring (common = 0 V)



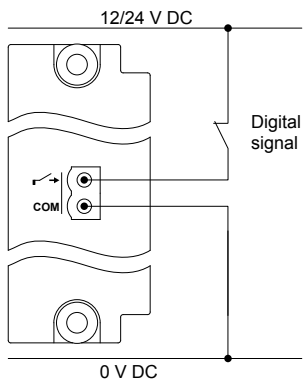
### Digital input wiring (common = 12 or 24 V)



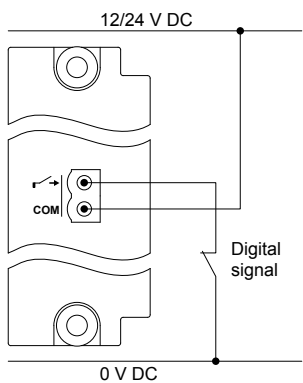
### Safety function wiring

Safety functions, for example, *Emergency stop*, require a normally closed digital signal to be wired to the controller.

### Digital input wiring for safety functions (common = 0 V)



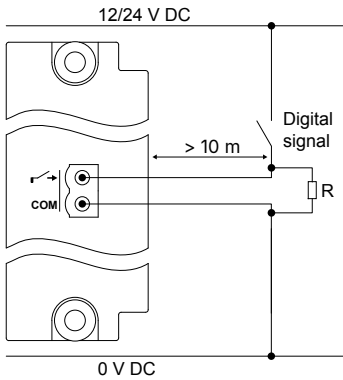
### Digital input wiring for safety functions (common = 12 or 24 V)



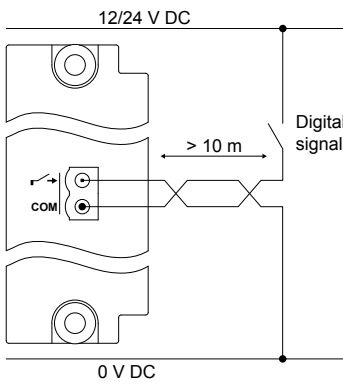
## Compliance with EN60255-26

If the wire to an open contact is over 10 m long, then additional measures are required for compliance with EN60255-26. You can use a 1 k $\Omega$  resistor to common, or you can use a twisted or shielded wire to the open contact.

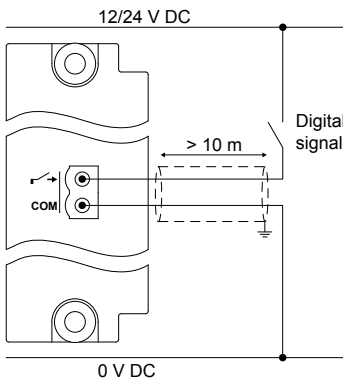
### 1 k $\Omega$ resistor to common for compliance with EN60255-26



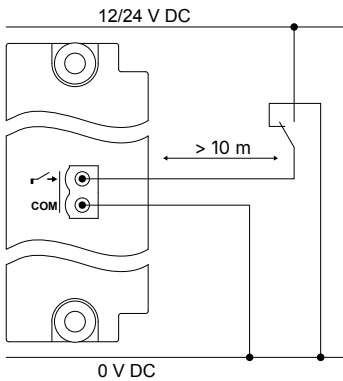
### Twisted wire for compliance with EN60255-26



### Shielded wire for compliance with EN60255-26



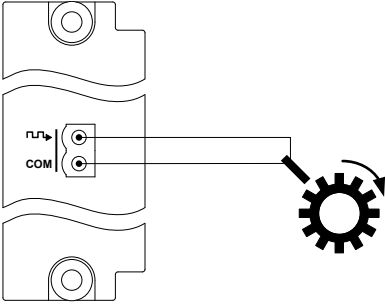
### Closed contact for compliance with EN60255-26



### 4.10.7 Magnetic pickup unit (MPU) input wiring

If you use the MPU input, you cannot at the same time use the W input. Connecting both the MPU and W inputs at the same time will lead to incorrect readings.

The MPU input wiring is shown in the following diagram. You can swap the MPU terminal connections around on the equipment without affecting the performance. If an MPU is used, a wire break can be detected.

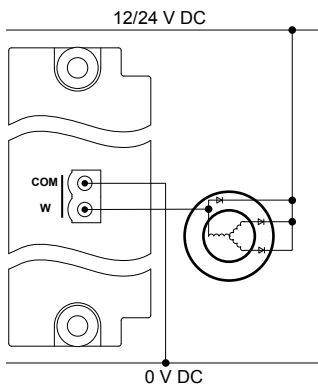


### 4.10.8 W input wiring

The W input can be used for a signal from one of the phases of the generator, or for an NPN or PNP input.

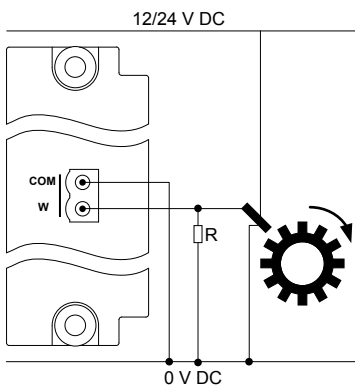
If you use the W input, you cannot at the same time use the MPU input. Connecting both the MPU and W inputs at the same time will lead to incorrect readings.

The connection of the W output from the generator is shown below.



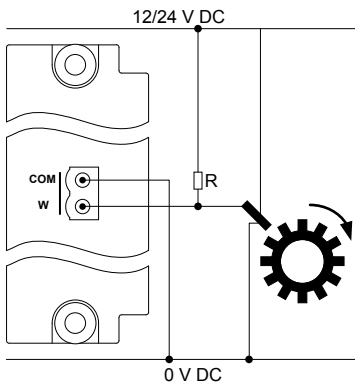
#### PNP input to W terminal

The connection of a PNP input, with a pull-down resistor, is shown below. The resistor, with resistance as recommended by the PNP supplier, should be placed close to the controller module.



## NPN input to W terminal

The connection of an NPN input, with a pull-up resistor, is shown below. The resistor, with resistance as recommended by the NPN supplier, should be placed close to the controller module.



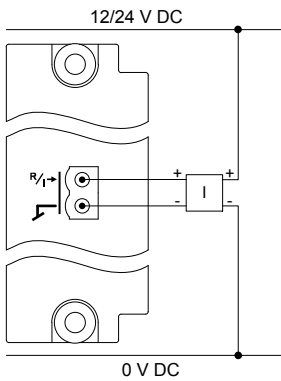
## 4.10.9 Analogue current or resistance inputs wiring

The I/O configuration determines whether the input is current or resistance. For resistance, the I/O configuration also determines the type of resistance input.

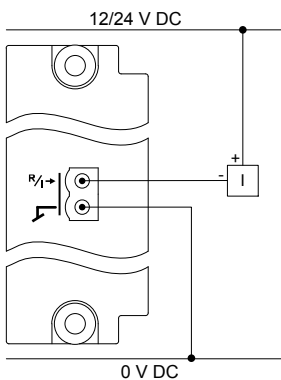
### Current input

The current input may be either active or passive, and a combination of active and passive inputs may be used.

**Figure 4.15** Connection of an active transducer



**Figure 4.16** Connection of a passive transducer

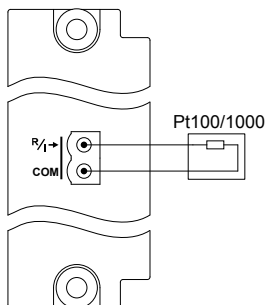


### Resistance input

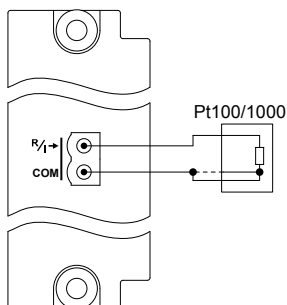
The resistance inputs are always passive inputs. The controller sends a small current through the external equipment and measures the resistance.

**NOTE** There is no software compensation for the wire length to the resistance input.

**Figure 4.17** Connection of a 2-wire Pt100/1000 sensor

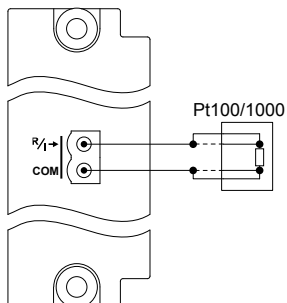


**Figure 4.18** Connection of a 3-wire Pt100/1000 sensor



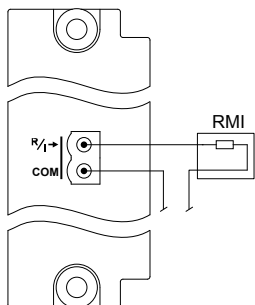
You do not have to connect the third wire (shown by the dashed line). If you want to connect the third wire, connect it to the common, as shown in the diagram.

**Figure 4.19** Connection of a 4-wire Pt100/1000 sensor

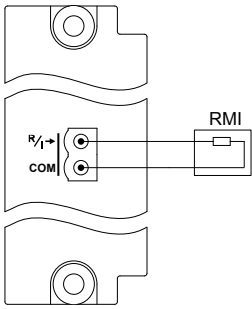


You do not have to connect the third and fourth wires (shown by the dashed lines). If you want to connect them, connect them as shown in the diagram.

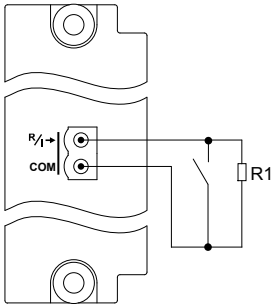
**Figure 4.20** Connection of a 1-wire resistance measurement input (RMI)



**Figure 4.21** Connection of a 2-wire resistance measurement input (RMI)



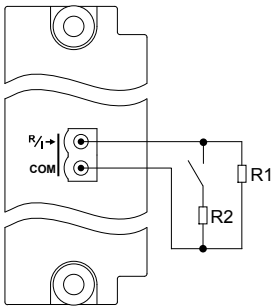
**Figure 4.22** Connection of a dry contact with cable supervision



Requirements:

- The maximum resistance for the circuit and resistor ( $R1$ ) is  $330 \Omega$ .
- $R1$  must be connected to the switch, and not to the controller terminals.

**Figure 4.23** Connection of a dry contact with cable supervision, and short circuit detection



Requirements:

- The maximum resistance for the circuit and resistor ( $R1$ ) is  $330 \Omega$ .
- The resistance of  $R2$  must be less than  $R1$ .
- $R1$  must be connected to the switch, and not to the controller terminals.

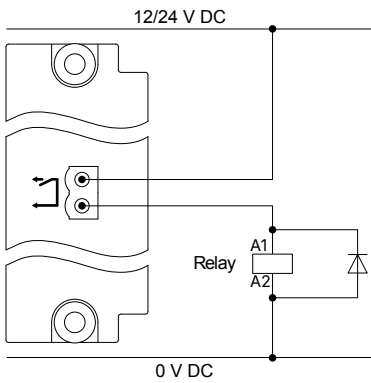
## 4.11 Governor and AVR module GAM3.1

### 4.11.1 GAM3.1 terminal connections

	Term	Symbol	Name	Type	Default
	1		Normally open	Relay output (250 V AC or 30 V DC, and 6 A)	Configurable
	2		Common		
	3		Normally open	Relay output (250 V AC or 30 V DC, and 6 A)	Configurable
	4		Common		
	5		Normally open	Relay output (250 V AC or 30 V DC, and 6 A)	Configurable
	6		Common		
	7		Normally open	Relay output (250 V AC or 30 V DC, and 6 A)	Configurable
	8		Common		
	9		Active (P) load	Voltage output: -5 to 5 V DC, Impedance: 23.5 kΩ	
	10	COM	Common	Common to terminals 9 or 10	
	11		Reactive (Q) var	Voltage output: -5 to 5 V DC, Impedance: 23.5 kΩ	
	12		Output	<b>Analogue current or voltage output:</b> <b>Current:</b> 0 to 20 mA, 4 to 20 mA, or -20 to 20 mA <b>Voltage (DC):</b> 0 to 10 V, -10 to 10 V, 0 to 5 V, 0 to 3 V, -3 to 3 V, 0 to 1 V	
	13		Common		
	14		PWM output	Frequency: 500 Hz ±50 Hz, Resolution: 43,200 levels, Voltage: 0.05 to 6.85 V	Pulse width modulation (PWM) output
	15		Common		
	16		Output	<b>Analogue current or voltage output:</b> <b>Current:</b> 0 to 20 mA, 4 to 20 mA, or -20 to 20 mA <b>Voltage (DC):</b> 0 to 10 V, -10 to 10 V, 0 to 5 V, 0 to 3 V, -3 to 3 V, 0 to 1 V	Configurable
	17		Common		
	18		Input	<b>Analogue current or voltage input:</b> <b>Current:</b> 0 to 20 mA, or 4 to 20 mA <b>Voltage (DC):</b> -10 to 10 V, 0 to 10 V	Configurable
	19		Common		
	20		Input	<b>Analogue current or voltage input:</b> <b>Current:</b> 0 to 20 mA, or 4 to 20 mA <b>Voltage (DC):</b> -10 to 10 V, 0 to 10 V	Configurable
	21		Common		

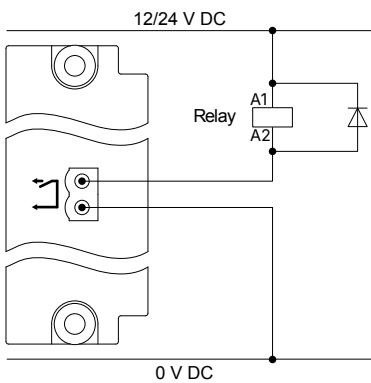
### 4.11.2 Relay output wiring


The diagram shows the connection of the relay output to an external relay. There is no voltage on the external relay when the controller relay is open.



Use a diode size as recommended by the relay supplier.

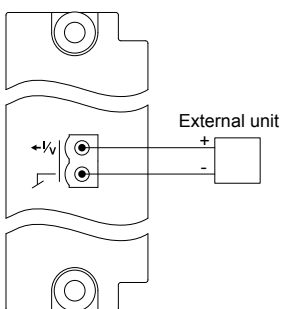
You can swap the terminal connections around without affecting the performance.



Install a freewheeling diode (  ) to prevent a sudden voltage spike across the inductive load when the voltage source is removed.

### 4.11.3 Analogue current or voltage outputs wiring

The diagram below shows the connection of an external controller to the DEIF controller's analogue current or voltage output. The I/O configuration determines whether the output is current or voltage.



## NOTICE

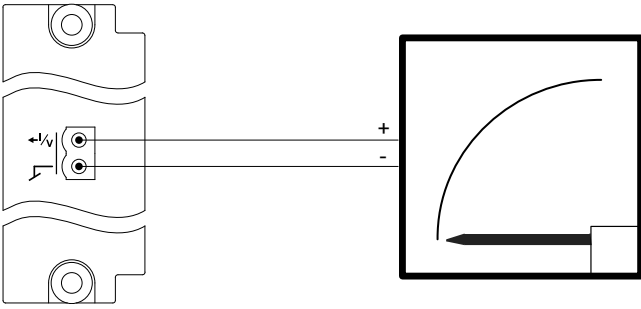
### Terminal damage

These outputs are active outputs. Do not connect an external power supply to these terminals. Connecting an external power supply may damage the terminals.

The PWM output is galvanically connected to the first analogue output (terminals 12 and 13) on GAM3.1. This means that wiring errors or noise on either output can affect the other output.

## Using an analogue output with a switchboard instrument

The analogue output can be connected directly to a 4 to 20 mA switchboard instrument.



We recommend using switchboard instruments from the DEIF DQ moving coil instrument series. See <http://www.deif.com> for more information.

### 4.11.4 Analogue current or voltage input wiring

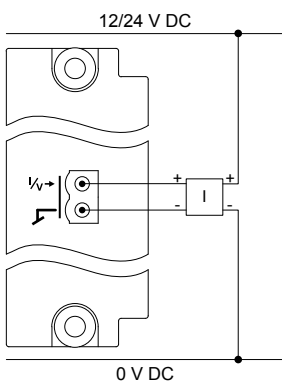
The I/O configuration determines whether the input is current or voltage.

Configure the terminals correctly (that is, for current or for voltage) before connecting the external transmitter.

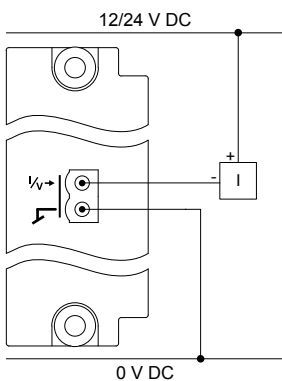
#### Current input

The current input may be either active or passive.

The following diagram shows the connection of an active transducer.



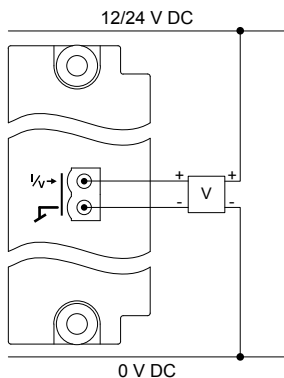
The following diagram shows the connection of a passive transducer.



The two analogue inputs on GAM3.1 are galvanically connected. You therefore cannot use the analogue inputs on GAM3.1 in series with each other, for example, if you wanted a backup measurement. If you need two analogue inputs in series, you can use an analogue input on another module in series with an analogue input on GAM3.1, since the modules are galvanically isolated from each other.

### Voltage input

The following diagram shows the connection for voltage input.



## 4.12 Governor and AVR module GAM3.2

### 4.12.1 GAM3.2 terminal connections

	Term	Symbol	Name	Type	Default
	FG		F/G	Ground	Frame ground
	1		+	12 or 24 V DC (nominal)	Power supply
	2		-	0 V DC	
	3		Analogue output	Analogue current or voltage output (Current: 0 to 20 mA, 4 to 20 mA, or -20 to 20 mA; Voltage (DC): 0 to 10 V, -10 to 10 V, 0 to 5 V, 0 to 3 V, -3 to 3 V, or 0 to 1 V)	Configurable
	4		Common		
	5		Analogue output	Analogue current or voltage output (Current: 0 to 20 mA, 4 to 20 mA, or -20 to 20 mA; Voltage (DC): 0 to 10 V, -10 to 10 V, 0 to 5 V, 0 to 3 V, -3 to 3 V, or 0 to 1 V)	Configurable/ PWM output
	6	COM	Common		
	7		PWM output	Pulse width modulation (PWM) output (Frequency: 500 Hz $\pm$ 50 Hz, Resolution: 43,200 levels, Voltage: 0.05 to 6.85 V)	
	8		Bi-directional input	Digital input (OFF: 0 to 2 V DC, ON: 8 to 36 V DC, Impedance: 4.7 k $\Omega$ )	Configurable
	9		Bi-directional input	Digital input (OFF: 0 to 2 V DC, ON: 8 to 36 V DC, Impedance: 4.7 k $\Omega$ )	Configurable
	10		Bi-directional input	Digital input (OFF: 0 to 2 V DC, ON: 8 to 36 V DC, Impedance: 4.7 k $\Omega$ )	Configurable
	11		Bi-directional input	Digital input (OFF: 0 to 2 V DC, ON: 8 to 36 V DC, Impedance: 4.7 k $\Omega$ )	Configurable
	12		Bi-directional input	Digital input (OFF: 0 to 2 V DC, ON: 8 to 36 V DC, Impedance: 4.7 k $\Omega$ )	Configurable
	13	COM	Common	Common for digital input terminals 8 to 12	
	14		Normally open	Relay output (250 V AC or 30 V DC, and 6 A)	GAM3.2 # status OK *
	15		Common		
	16		Normally open	Relay output (250 V AC or 30 V DC, and 6 A)	Configurable
	17		Common		
	18		Normally open	Relay output (250 V AC or 30 V DC, and 6 A)	Configurable
	19		Common		
	20		Normally open	Relay output (250 V AC or 30 V DC, and 6 A)	Configurable
	21		Common		
	22		Normally open	Relay output (250 V AC or 30 V DC, and 6 A)	Configurable
23		Common			

**NOTE** \* Default function cannot be changed.

## 4.12.2 Frame ground wiring

Create a protective earth:

1. Connect the frame ground terminal to the protective earth connection.
2. Connect the frame ground terminal to the cabinet.
3. Connect the rack to the cabinet.

The frame ground is connected to the power supply terminals through transient voltage suppression diodes (transorbs). In order to protect the frame ground and power supply, max. 36 V is allowed between the frame ground and the power supply terminals.

## 4.12.3 Power supply wiring

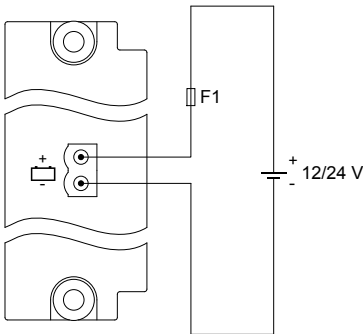
Connect the power supply (+) to the 12 or 24 V DC power supply, and the power supply (-) to the 0 V DC power supply.

### NOTICE

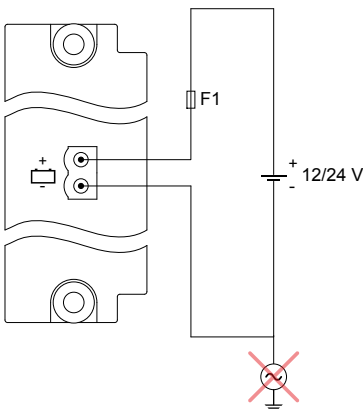
#### Negative power supply terminal

Do not wire the negative power supply terminal of the modules with independent power supplies (for example, PSM 3.1) to the single-phase ground. If the voltage between the power supply terminals and frame ground exceeds 36 V, the power supply terminals and the frame ground terminal will be damaged.

#### Recommended wiring for the power supply



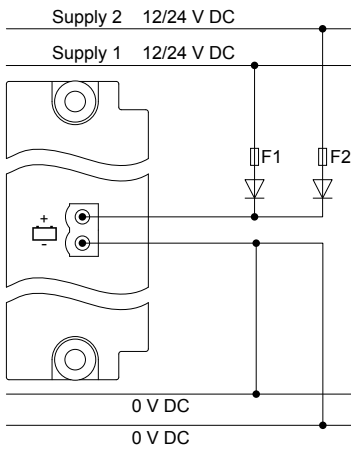
#### Incorrect wiring of the power supply



#### Backup power supply

The equipment does not contain a backup power supply. The power supply source must therefore include the necessary power backup.

## Example of a power supply and backup connected to the power supply terminals



We recommend a 2 A time-delay fuse for 24 V DC and a 4 A time-delay fuse for 12 V DC for F1 and F2, and that the diodes are rated 50V or higher.

### NOTICE

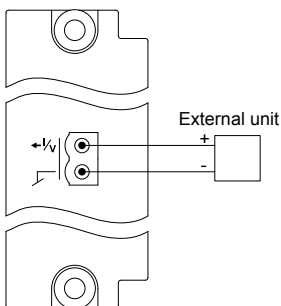


**Nominal auxiliary voltage is 12 or 24V DC (8 to 36 V DC operating range).**

If voltage drops are likely to appear, a 7 A time-delay fuse is needed.

## 4.12.4 Analogue current or voltage outputs wiring

The diagram shows the connection of an external controller to the DEIF controller's analogue current or voltage output. The I/O configuration determines whether the output is current or voltage.



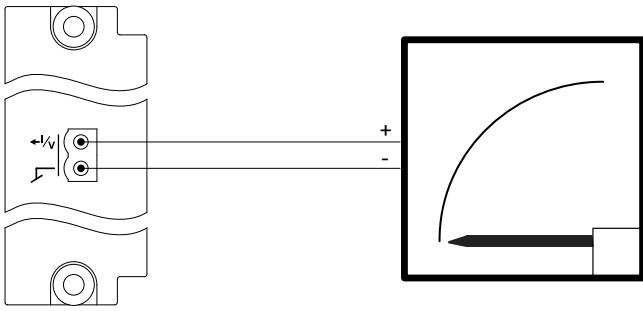
### NOTICE

#### Terminal damage

These outputs are active outputs. Do not connect an external power supply to these terminals. Connecting an external power supply may damage the terminals.

## Analogue output with an external instrument

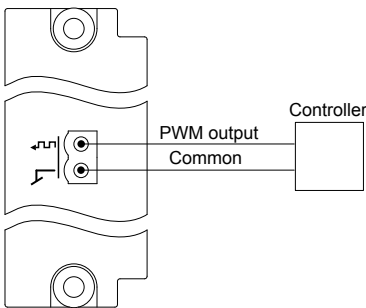
The analogue output can be connected directly to a 4 to 20 mA external instrument.



We recommend you use instruments from the DEIF DQ moving coil instrument series. See [www.deif.com](http://www.deif.com) for more information.

#### 4.12.5 Pulse width modulation (PWM) output wiring

Pulse width modulation (PWM) output is normally used to control a governor, but you can also use the PWM as an input for another controller.



#### 4.12.6 Digital input wiring

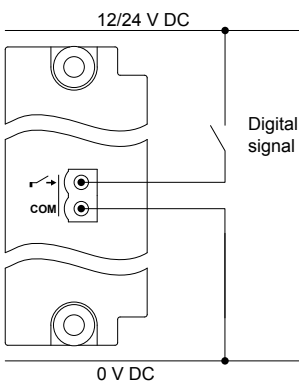
The digital inputs are bi-directional, so you can swap the terminal connections around without affecting the performance..

However, all the digital inputs in a group share a common terminal. The digital input common for a module may be either low (connected to 0 V), or high (connected to 12 or 24 V):

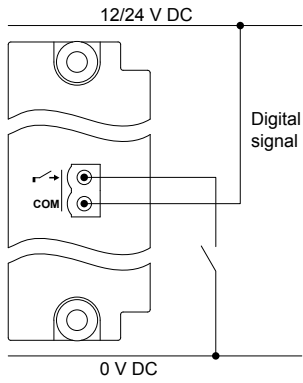
- If common is low: All the digital input signals connected to the group must be high (connected to 12 or 24 V).
- If common is high: All the digital input signals connected to the group must be low (connected to 0 V).

The digital input common is not used as the common for any of the other terminals on the same hardware module. The digital input common is also not affected by the digital input commons on other hardware modules.

##### Digital input wiring (common = 0 V)



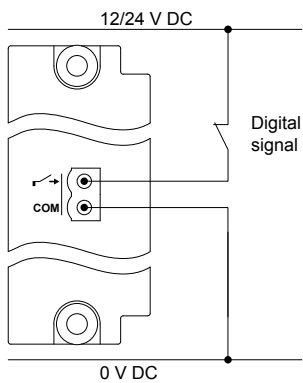
## Digital input wiring (common = 12 or 24 V)



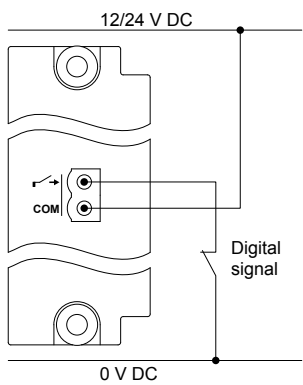
## Safety function wiring

Safety functions, for example, *Emergency stop*, require a normally closed digital signal to be wired to the controller.

## Digital input wiring for safety functions (common = 0 V)



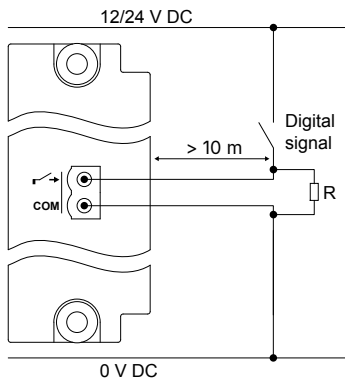
## Digital input wiring for safety functions (common = 12 or 24 V)



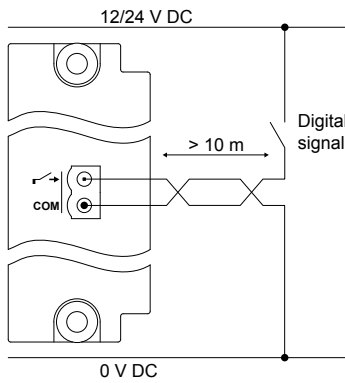
## Compliance with EN60255-26

If the wire to an open contact is over 10 m long, then additional measures are required for compliance with EN60255-26. You can use a 1 k $\Omega$  resistor to common, or you can use a twisted or shielded wire to the open contact.

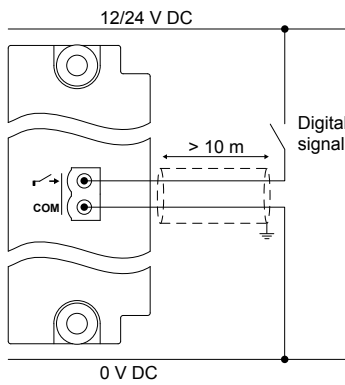
### 1 kΩ resistor to common for compliance with EN60255-26



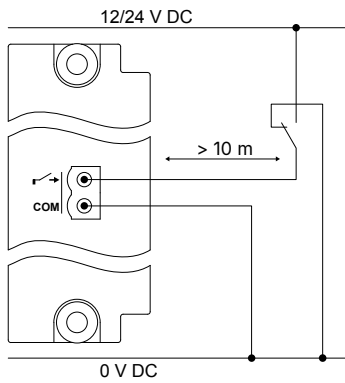
### Twisted wire for compliance with EN60255-26



### Shielded wire for compliance with EN60255-26

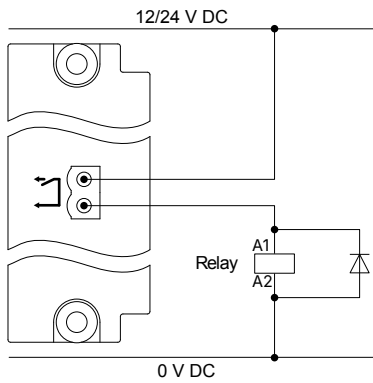


### Closed contact for compliance with EN60255-26



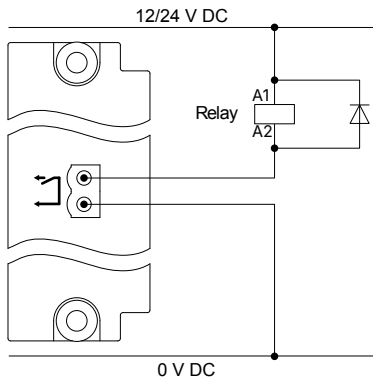
## 4.12.7 Relay output wiring


The diagram shows the connection of the relay output to an external relay. There is no voltage on the external relay when the controller relay is open.



Use a diode size as recommended by the relay supplier.

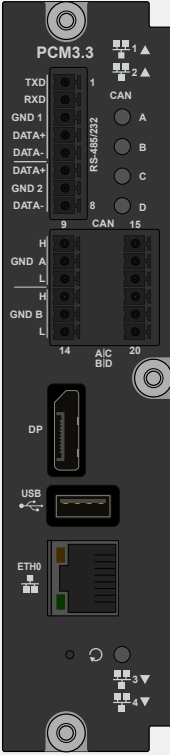
You can swap the terminal connections around without affecting the performance.



Install a freewheeling diode (  ) to prevent a sudden voltage spike across the inductive load when the voltage source is removed.

## 4.13 Processor and communication module PCM3.3

### 4.13.1 PCM3.3 terminal connections

Module	Count	Symbol	LED	Type	Name
	5	ETH0 1 to 4	<ul style="list-style-type: none"> <li>● <b>Off</b> : No communication</li> <li>● <b>Green</b> : Communication connected</li> <li>🌟 <b>Green flash</b> : Active communication</li> </ul>	Ethernet (RJ45)	ETH0 on the front. Switch Ports 1 and 2 (SWP1, SWP2) located connections at the top. Switch Ports 3 and 4 (SWP3, SWP4) located connections at the bottom.
	1	🔄	<ul style="list-style-type: none"> <li>● <b>Off</b> : Self-check not OK</li> <li>● <b>Green</b> : Self-check OK</li> <li>🌟 <b>Green flash</b> : In service mode</li> </ul>		
	1			Internal push-button *	
	1	USB		USB host (Type-A)	
	1	DP		DisplayPort (DP full size)	
	4	A to D H, GND, L	<ul style="list-style-type: none"> <li>● <b>Off</b> : No communication</li> <li>● <b>Green</b> : CAN connected</li> <li>🌟 <b>Green flash</b> : Active CAN communication</li> </ul>	CAN port	CAN bus
	1			RS-232/485 port	
	1			RS-485 port	

**NOTE** \* Used for Factory reset. Can also be used with CODESYS if license is installed.

## 4.13.2 CAN bus ECU or DAVR communication

The CAN bus terminals on the PCM3.3 module can be used for communication with an ECU and/or DAVR.

Use 120  $\Omega$  (Ohm) shielded twisted pair cable. Terminating resistors at the ends of the cable must be 120  $\Omega$  (Ohm).

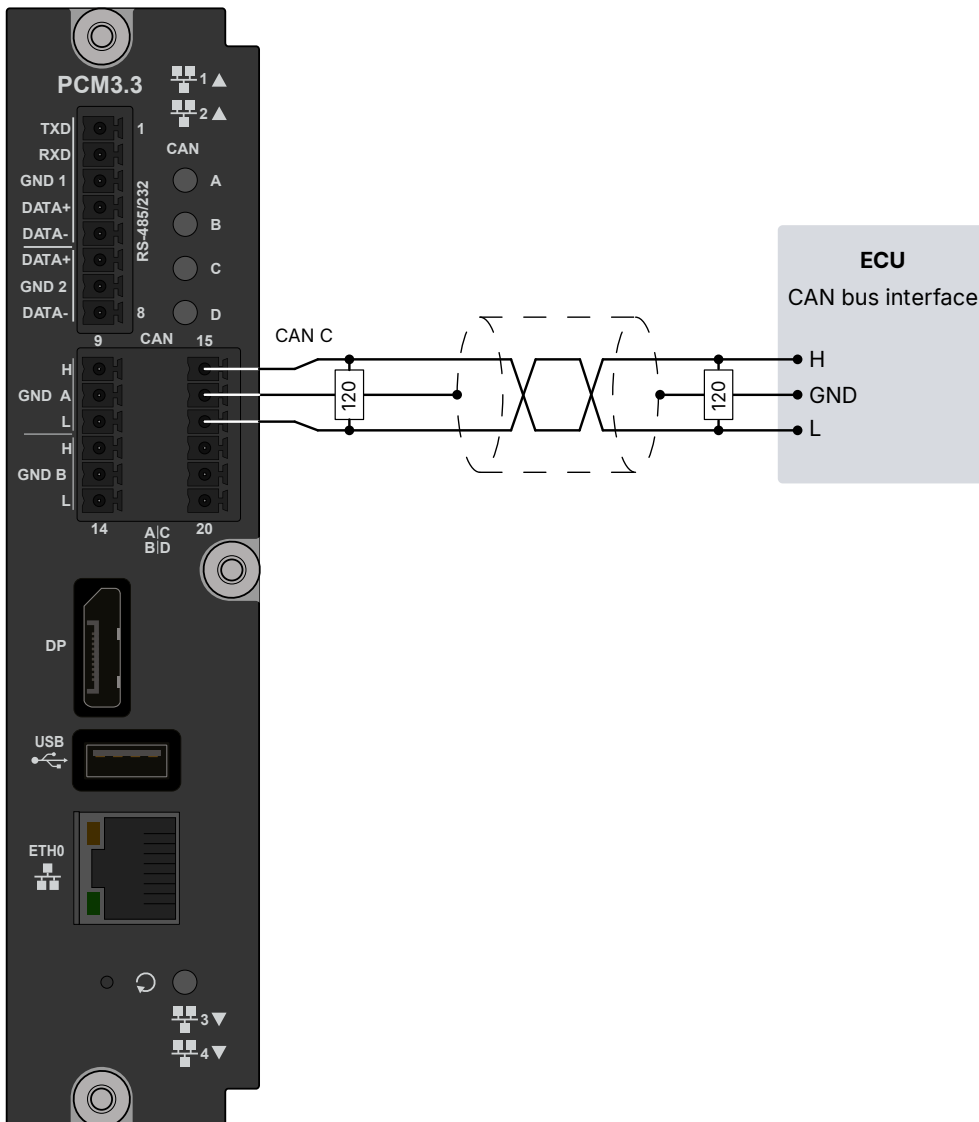
The ECU may include a terminating resistor (see the engine manufacturer's information).



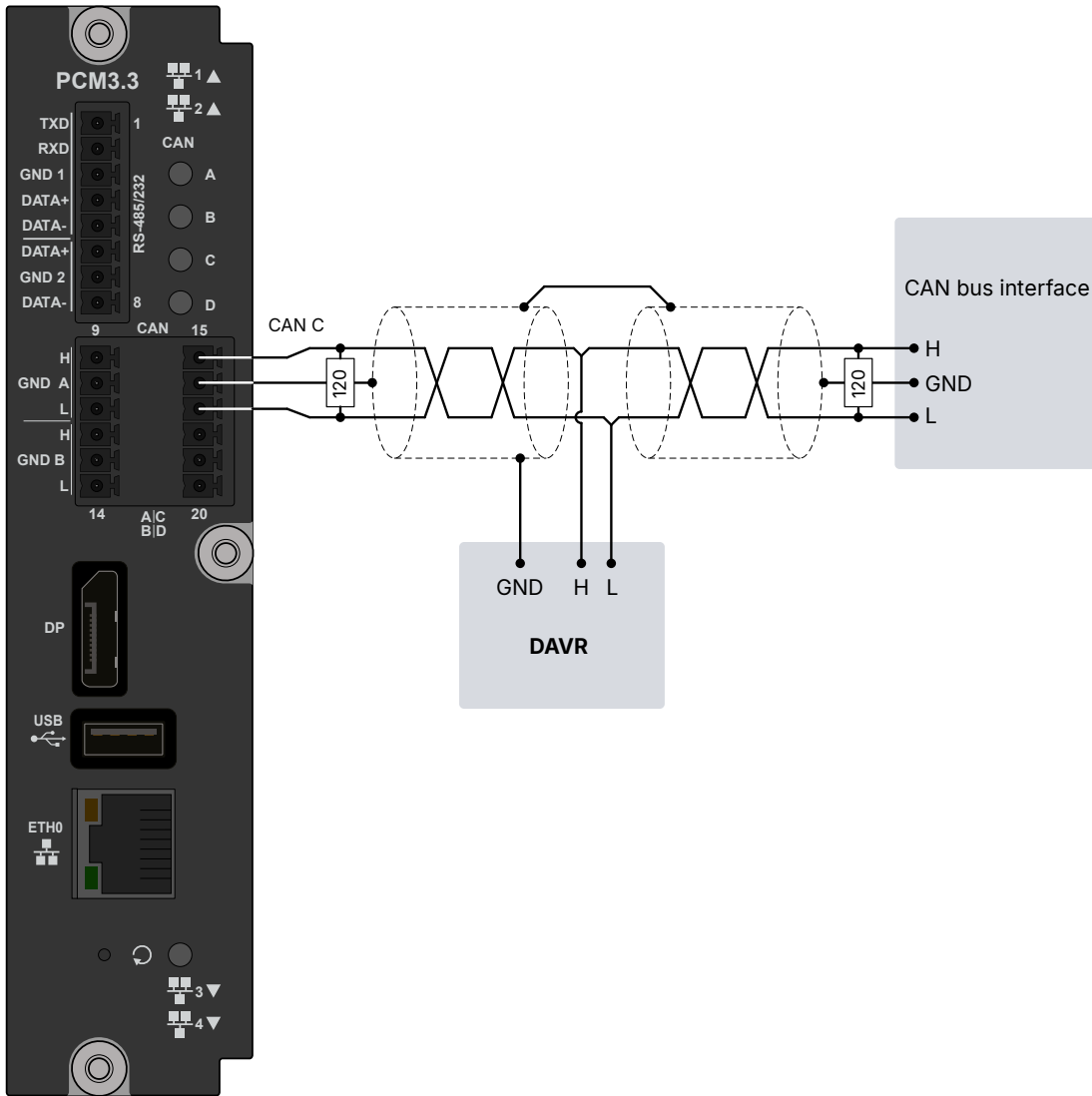
### Example cable

Belden 3105A or equivalent, 22 AWG (0.33 mm<sup>2</sup>) twisted pair, shielded, impedance 120  $\Omega$  (Ohm), < 50 m $\Omega$ /m, min. 95 % shield coverage.

### Wiring to ECU only

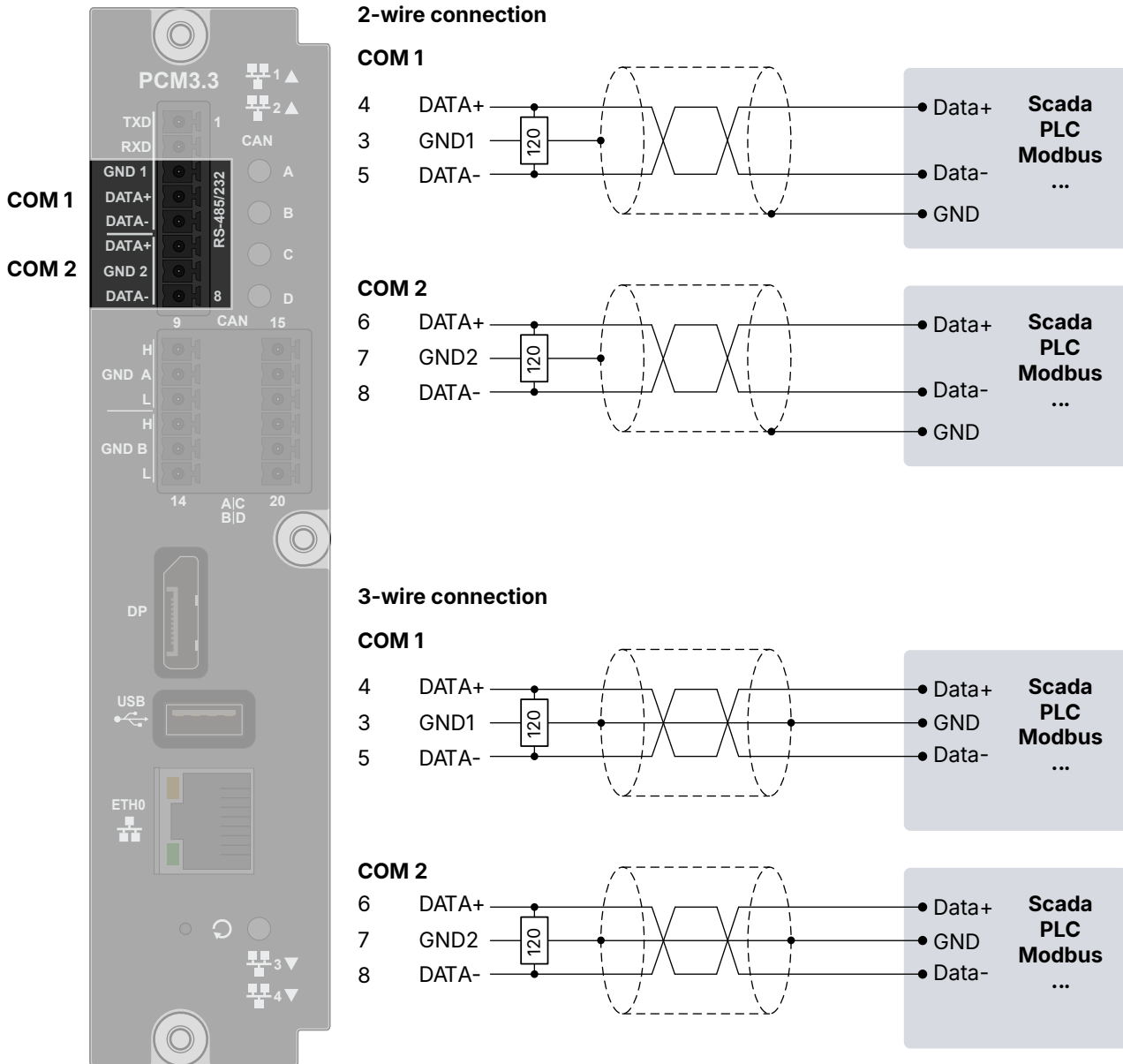


## Wiring to ECU with DAVR



### 4.13.3 Serial communication COM 1 / COM 2

Can be used for example to Modbus RTU, SCADA systems, or PLCs. CODESYS is required.

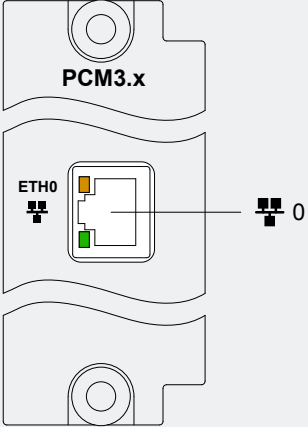
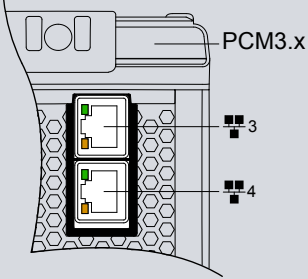


#### 4.13.4 PCM3.3 Network connections

The Ethernet connections are used for both internal and external communication. Internal communication to other controllers. External communication for SCADA, Modbus TCP, or AMS.

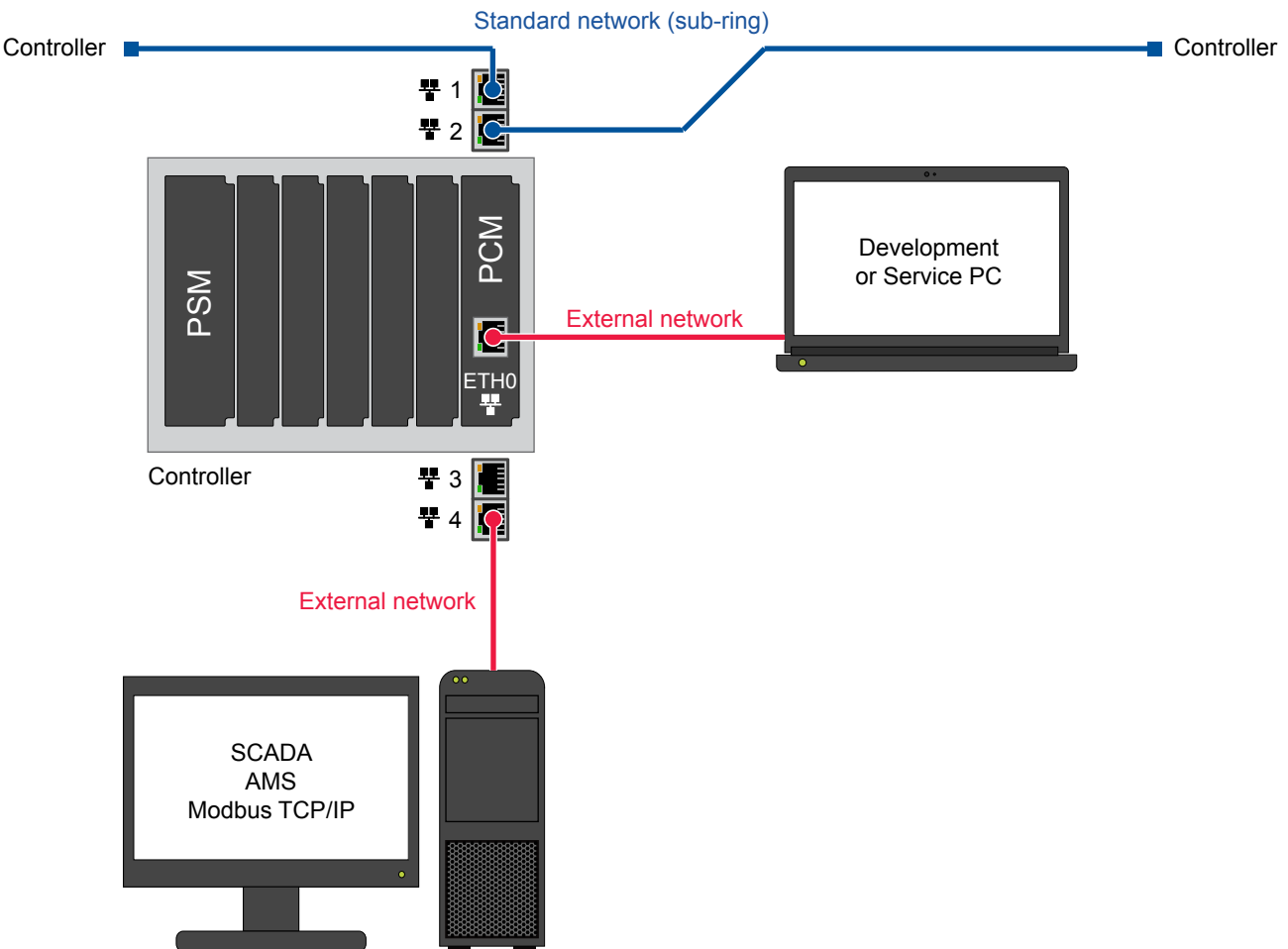
**Table 4.4** Location of the network communication ports on PCM3.3

Symbol	Symbol	Port location	Notes
		Top of rack, top port	Network communication (SWP1).
		Top of rack, bottom port	Network communication (SWP1).

Symbol	Symbol	Port location	Notes
 <p>PCM3.x</p> <p>ETH0</p> <p>0</p>	ETH0	Port on faceplate	Network communication (ETH0).
 <p>PCM3.x</p> <p>3</p> <p>4</p>	3	Bottom of rack, top port	Network communication (SWP3).
	4	Bottom of rack, bottom port	Network communication (SWP4).

### Configurable Ethernet ports

The Ethernet ports on the PCM3.3 are not assigned to a particular service. By default these are configured as **Automatic**. The controllers detect the equipment connected to the port.



## NOTICE



### Cybersecurity

Connections to untrusted networks may require additional equipment or security counter-measures not included in the product.

### Network restrictions

- The Ethernet cables must not be longer than 100 metres, point-to-point.
- The Ethernet cables must meet or exceed the SF/UTP CAT5e specification.
- The EtherCAT communication ports on the PSM must not be used for the network communication. They are used to connect controllers to extension racks.

### Ethernet port protectors

The controllers have two Ethernet port protectors that cover the Ethernet ports on the top of the controller to protect from dust or other foreign objects during the installation. We recommend that the port protectors remain installed in the ports when these are not in use.

### Cable bend radius

Bends in the cables must not be tighter than the minimum bend radius specified by the cable manufacturer. We recommend that you always follow the cable manufacturer's bend radius requirements.

### 4.13.5 External third-party display

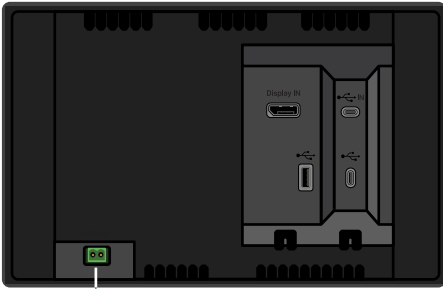
External third-party non-DEIF displays connected to the DisplayPort, should be configured to **Input** mode instead of **Automatic** detection.

## 4.14 Display

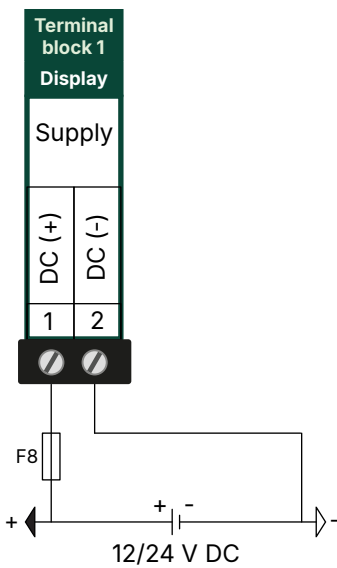
### 4.14.1 iE 7 display Power supply

Connect the power supply (+) to the 12 or 24 V DC power supply, and the power supply (-) to the 0 V DC power supply.

Display



Power supply



#### Fuse

- F7: 2 A DC max. time-delay fuse/MCB, c-curve

### NOTICE



**Nominal auxiliary voltage is 12 or 24 V DC (8 to 36 V DC operating range).**

For F7, if voltage drops are likely, a 4 A time-delay fuse may be needed.

## NOTICE

### Negative power supply terminal



In marine applications, do not wire the negative power supply terminal of the modules with independent power supplies to the ship single-phase ground. If the voltage between the power supply terminals and frame ground exceeds 36 V, the power supply terminals and the frame ground terminal will be damaged.

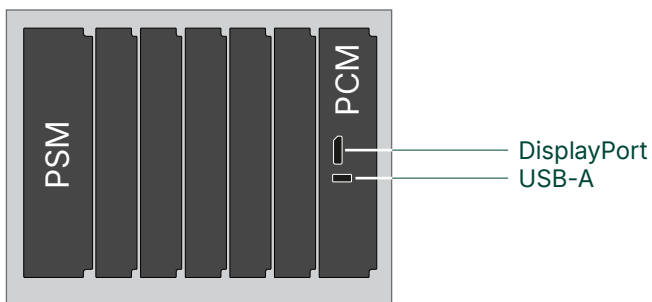
The negative power supply terminal on the iE 7 display, must be connected to the negative power supply terminal on the controller power supply, to make an equipotential bonding conduction. See [PSM Power supply wiring](#).

## 4.14.2 iE 7 display connections

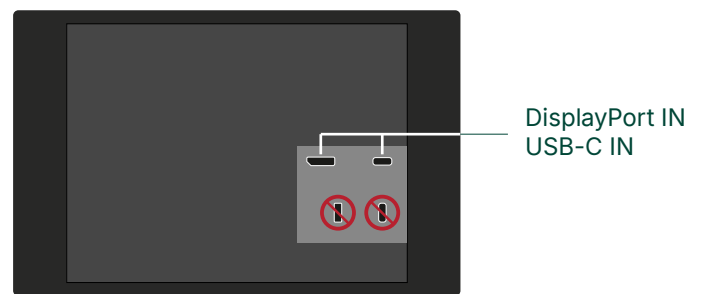
The display has inputs for **DisplayPort IN** and **USB type C IN**. It also has additional USB communication ports for future use.

The **DisplayPort IN** and **USB type C IN** are needed to connect and operate to the base-mounted controller.

Controller



Display



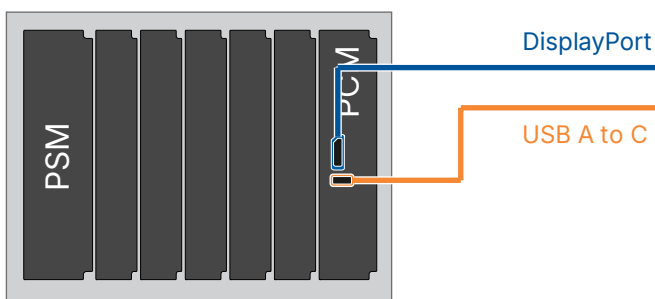
The additional USB ports on the display are for future use.

### Connection constraints

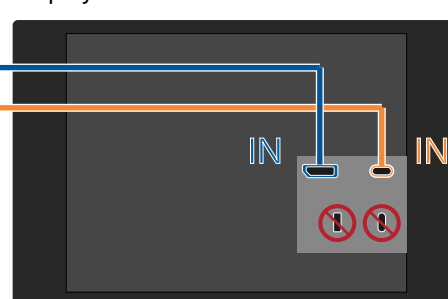
- The display is only for use with a base-mounted controller.
- The **DisplayPort IN** and **USB type C IN** cables must be connected to operate the base-mounted controller.
- Controllers must be connected directly without a USB hub or similar.
- All USBs support 2.0.
- Both the DisplayPort and USB A to C cables are supplied.
- Connection to the display must use the ports marked **IN**.

### Base-mounted controller to display connection

Controller



Display



USB Connection to display must use USB IN.

## 5. Maintenance

### 5.1 Precautions before maintenance

#### NOTICE



##### Correct handling of modules

Failure to follow these instructions could lead to damage to the modules.  
Read and follow the instructions to avoid damage to the modules.

#### NOTICE



##### Changing modules with maritime approvals

If you replace a hardware module with a different type, the controller loses its maritime classification societies' approvals.  
Replacing with a module of the same type will not affect maritime classification societies' approvals.

#### NOTICE



##### Changing module order

If you rearrange the order of the hardware modules, you will lose the modules' configuration.  
Always make a backup before changing hardware modules.

### 5.2 Personnel and equipment protection



#### DANGER!



##### Hazardous live currents and voltages

Hazardous live currents and voltages may be present in an installed rack. Contact with these could kill you. Only authorised personnel, who understand the precautions needed and the risks involved in working with live electrical equipment, may do this work.



#### CAUTION



##### Disrupting control

Working on the rack may disrupt the control of the generator, busbar or connection. Take the necessary precautions.



#### CAUTION



##### Protecting equipment: No hot swapping

Disconnect all power supplies before replacing any modules or the PCM battery.

## NOTICE

### Electrostatic discharge



During manufacturing and testing, the products have been kept in static shielding bags, and all personnel handling the products have been protected against static electricity and the subsequent ESD (electrostatic discharge).

Be sure to carry a connection to earth when handling our PCBs.

## NOTICE

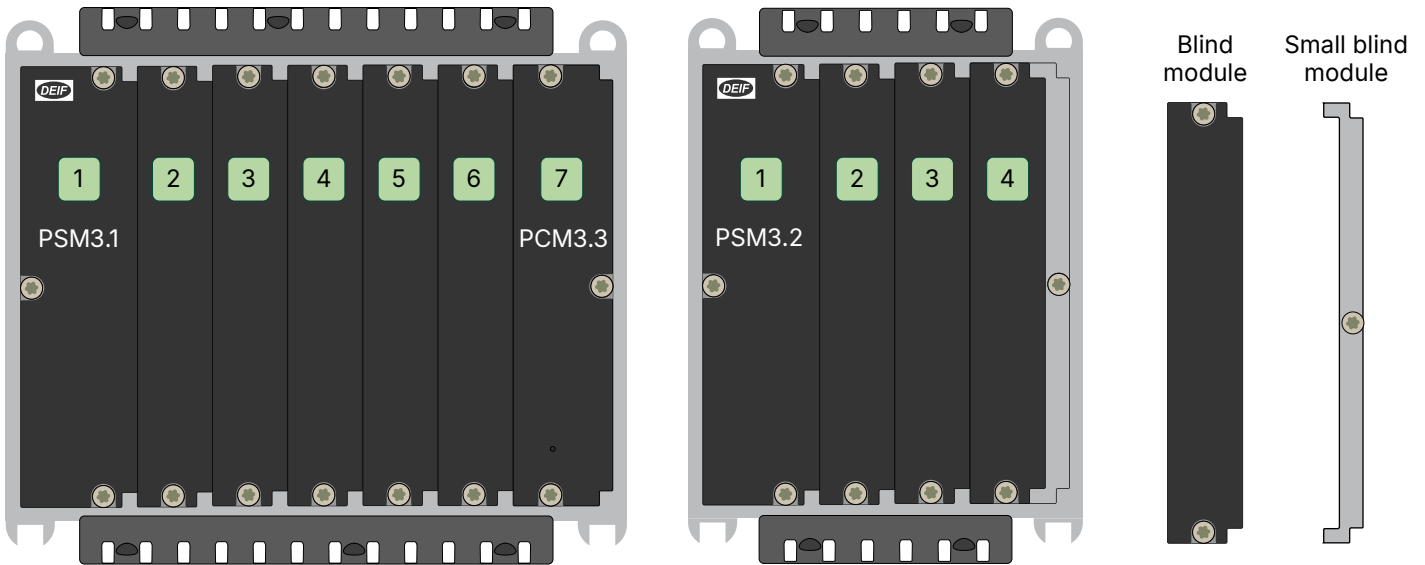


### Torque damage to equipment

Do not use power tools during the installation/replacement. Too much torque damages the equipment.

Follow the instructions for the correct amount of torque to apply.

## 5.3 Rack slot requirements



Modules can be installed in either rack R7.1 (7 slots) or R4.1 (4 slots). The modules can be arranged in any order in the rack, but must comply with these requirements.

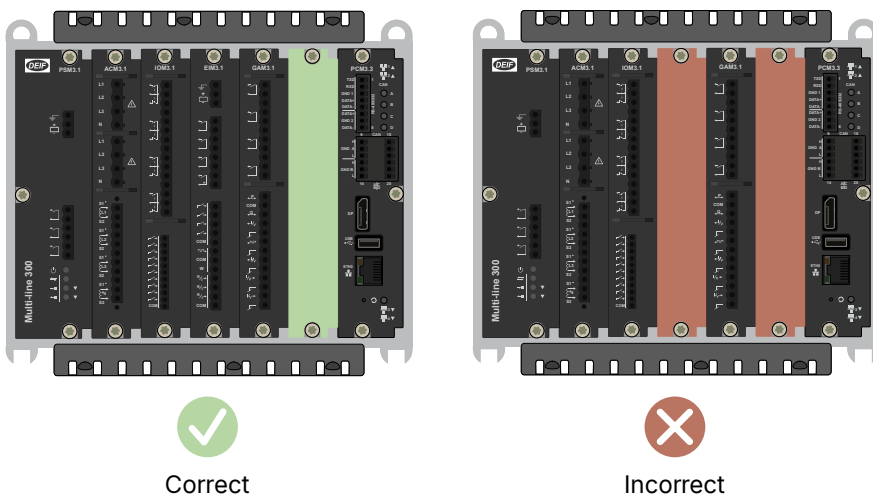
R7.1 (7 slots)		R4.1 (4 slots)	
Controllers	Extension racks	Controllers	Extension racks
Slot 1 must have the <b>PSM3.1</b> .	Slot 1 must have the <b>PSM3.2</b> .	Slot 1 must have the <b>PSM3.1</b> .	Slot 1 must have the <b>PSM3.2</b> .
Slot 7 must have the <b>PCM3.3</b> .	Other modules can be used in slot 7 but must have the <b>small blind module</b> .	Slot 4 must have the <b>PCM3.3</b> .	Other modules can be used in slot 4 but must have the <b>small blind module</b> .

Blind modules (blank faceplates) must be installed over empty slots to protect the rack.

### Order of the modules

All other hardware modules must installed from left to right from slot 2 onwards without empty slots between modules.

There can only be adjacent empty slots between the last module and the **PCM3.3** or end of the rack.



If slots are empty between the hardware modules, the modules after the empty slot(s) **cannot communicate** with the **PCM3.3** module.

## 5.4 Change hardware modules

Each module is fastened to the rack with TX20 screws.

These should be loosened before the extraction handles are used to lift the module free of the rack.

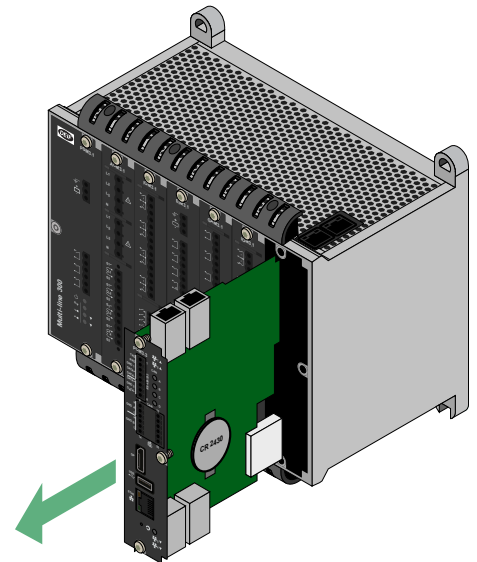
They do not remove completely from the hardware module.

Hold the module by the faceplate. Do **not** touch the PCB.



### More information

See [Maintenance](#) for how to change the PCM battery.



### 5.4.1 No hot swapping modules



**DANGER!**

#### Do not hot swap modules



It is not allowed to hot swap any modules. Hot swapping modules can be extremely dangerous to both personnel and the equipment.

Make sure the system is shutdown and power supply has been isolated and switched off.



Isolate the power supply.



Protect the modules against static discharge.



Do not alter state during installation.




Avoid touching the PCB or terminal pins.



### More information

See [Warnings and safety](#) for full details of all precautions to take during installation.

## 5.4.2 Remove hardware modules

1.  Protect the hardware modules against static discharge.

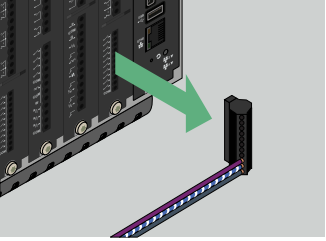


It is recommended to use a wrist strap connection to protect against Electrostatic discharge (ESD).

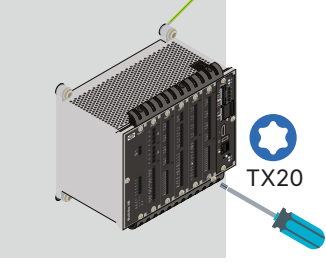
Test the resistance of the wrist strap and the wrist strap connection. **Do not continue** if the wrist strap connection is faulty. Use the wrist strap at all times while installing or uninstalling any modules.

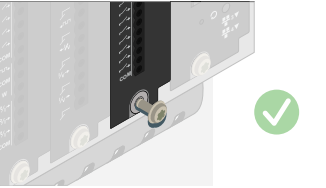
2.  The controller **must not be powered**.

Disconnect all power supplies to protect the hardware modules and personnel.

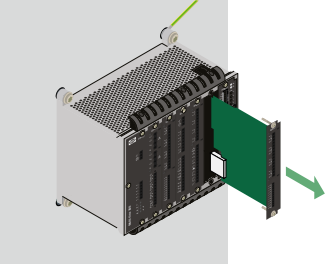
3.  Remove all terminal blocks, and make sure that there are no wires in the way of removing the hardware module.

For PSM or PCM modules, disconnect any Ethernet cables from the top and bottom.

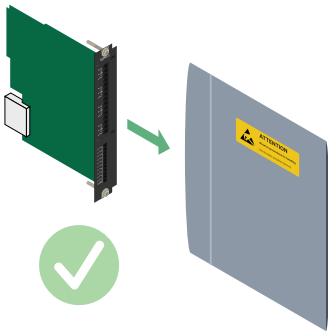
4.  Loosen the module faceplate screws with a TX20 screwdriver.

5.  Do not force the screws to unscrew completely.

The screws are built-in and should remain attached to the faceplate.

6.  Use pliers or your fingers to pull the faceplate screws, and carefully slide the hardware module out of the rack.

7.



Hold the module by the faceplate.

Do **not** touch the PCB.

Put the hardware module in an ESD protective package when not installed in the rack.

### 5.4.3 Mount hardware modules

1. Protect the hardware modules against static discharge.



It is recommended to use a wrist strap connection to protect against Electrostatic discharge (ESD).

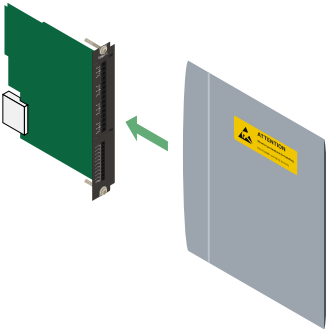
Test the resistance of the wrist strap and the wrist strap connection. **Do not continue** if the wrist strap connection is faulty. Use the wrist strap at all times while installing or uninstalling any modules.

2. The controller **must not be powered**.

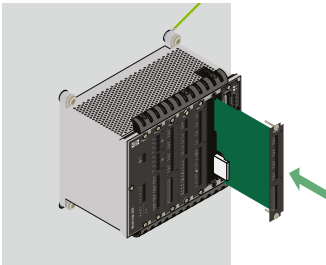


Disconnect all power supplies to protect the hardware modules and personnel.

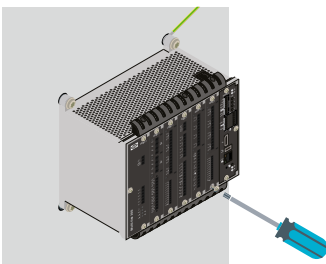
3. Open the ESD protective package, and remove the new module, hold it only by the faceplate.



4. Slide the module into the correct slot (it should slide in easily).

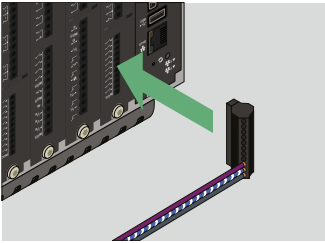


5. Tighten the screws on the module faceplate with a TX20 screwdriver.



Do not exceed the recommended torque of 0.5 N·m (4.4 lb-in).

6.



Replace all terminal blocks.

For PSM or PCM modules, replace any Ethernet cables to the top and bottom.

7.



If the rack is not mounted, return the rack to its protective packaging.

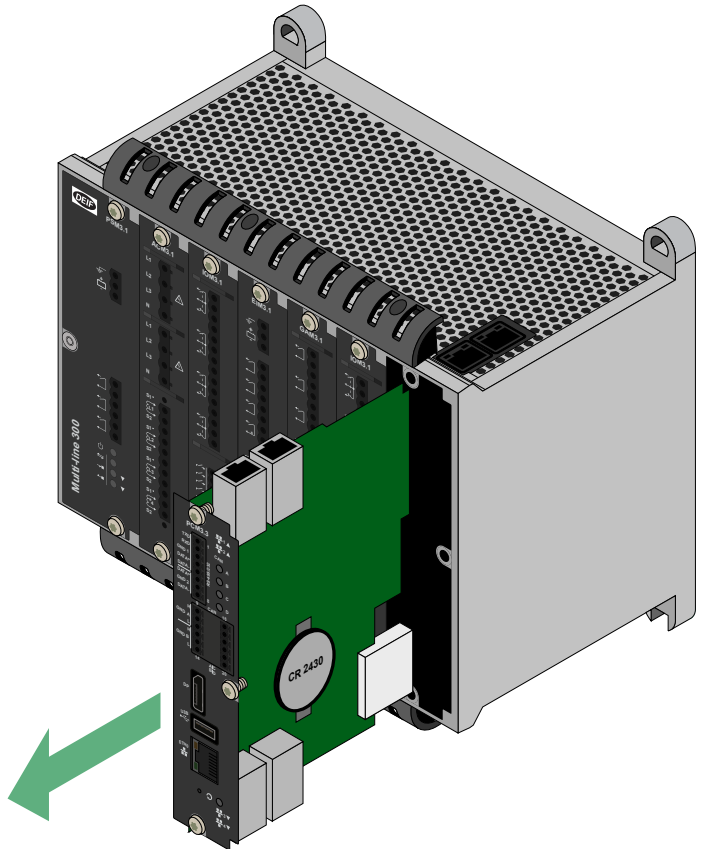
## 5.5 Replace RTC battery

### 5.5.1 Location of RTC battery on PCM3.3 module

The **PCM3.3** has a lithium battery for maintaining the real-time clock, when no power is applied.

A battery failure alarm is activated, when the battery power is low.

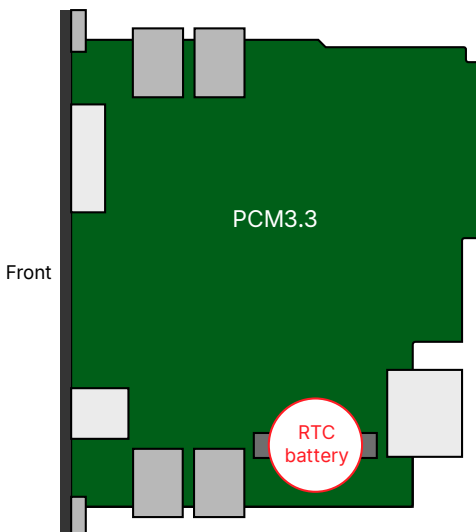
To replace the battery, you need to remove the PCM module.



The battery is a CR2430 3V battery, rated for operation at -40 to 85 °C (-40 to 185 °F).

This is **not** a standard CR2430 battery.

#### Location of the battery on module



## 5.5.2 How to replace the RTC battery

1. Protect the hardware modules against static discharge.



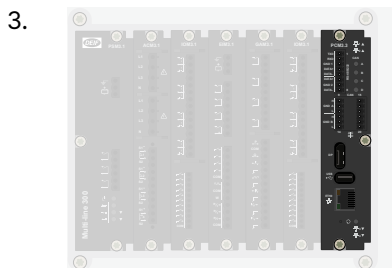
It is recommended to use a wrist strap connection to protect against Electrostatic discharge (ESD).

Test the resistance of the wrist strap and the wrist strap connection. **Do not continue** if the wrist strap connection is faulty. Use the wrist strap at all times while installing or uninstalling any modules.

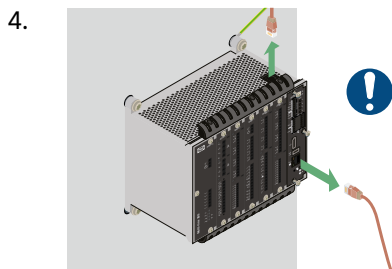


The controller **must not be powered**.

Disconnect all power supplies to protect the hardware modules and personnel.

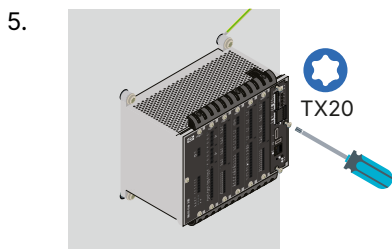


Locate the **PCM3.3** hardware module in the rack.



Remove all terminal blocks, and any Ethernet cables from the top and bottom.

Make sure that there are no wires in the way of removing the hardware module.

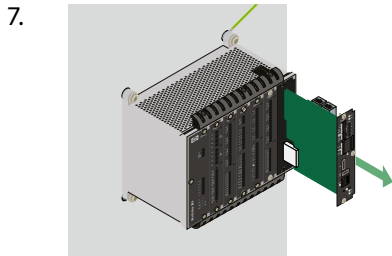


Loosen the module faceplate screws with a TX20 screwdriver.



Do not force the screws to unscrew completely.

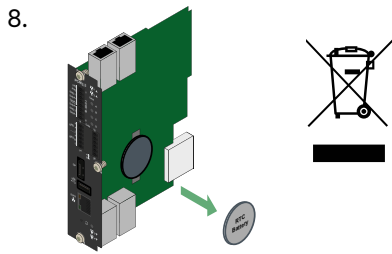
The screws are built-in and should remain attached to the faceplate.



Use pliers or your fingers to pull the faceplate screws, and carefully slide the hardware module out of the rack.

Hold the module by the faceplate.

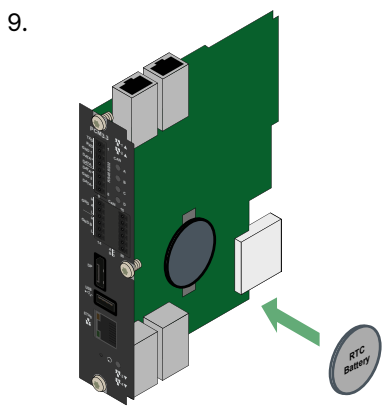
Do **not** touch the PCB.



Carefully remove the old battery from the holder.

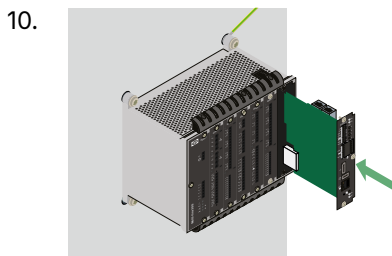
The old battery must be recycled or disposed of according to local laws and/or regulations.

 See [Disposal of waste electrical and electronic equipment](#).



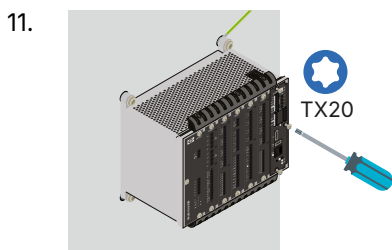
Make sure the polarity is correct.

Insert the new battery in the holder.



Make sure that the hardware module is the right way up.

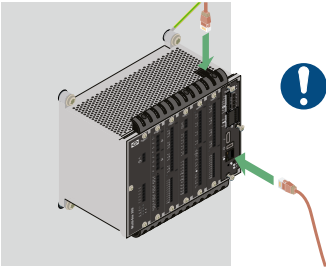
Slide the hardware module back into the rack (it should slide in easily).



Tighten the module faceplate screws with a TX20 screwdriver.

Do not exceed the recommended torque of 0.5 N·m (4.4 lb-in).

12.



Replace all terminal blocks, and any Ethernet cables at the top and bottom.

13.



You can now recommission the controller for operation.

## 6. End-of-life

### 6.1 Disposal of waste electrical and electronic equipment

WEEE symbol



All products that are marked with the crossed-out wheeled bin (the WEEE symbol) are electrical and electronic equipment (EEE). EEE contains materials, components and substances that can be dangerous and harmful to people's health and to the environment. Waste electrical and electronic equipment (WEEE) must therefore be disposed of properly. In the EU, the disposal of WEEE is governed by the WEEE directive issued by the European Parliament. DEIF complies with this directive.

You must not dispose of WEEE as unsorted municipal waste. Instead, WEEE must be collected separately, to minimise the load on the environment, and to improve the opportunities to recycle, reuse and/or recover the WEEE. In the EU, local governments are responsible for facilities to receive WEEE. If you need more information on how to dispose of DEIF WEEE, please contact DEIF.