

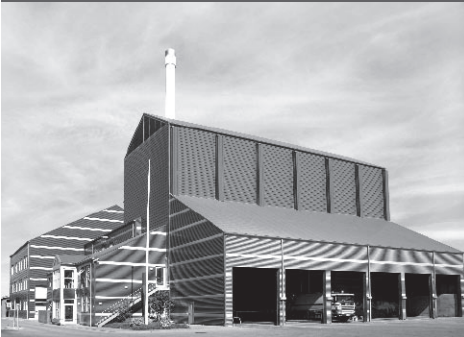

-power in control



AGC 200 Advanced Genset Controller APPLICATION NOTES



- Single generator set
- Automatic mains failure
- Parallel with mains (grid)
- Load sharing, multiple gensets
- Sensors



DEIF A/S · Frisenborgvej 33 · DK-7800 Skive
Tel.: +45 9614 9614 · Fax: +45 9614 9615
info@deif.com · www.deif.com

Document no.: 4189340611B
SW version: 4.21.x or later

1. General information	
1.1. Warnings, legal information and safety.....	3
1.1.1. Warnings and notes	3
1.1.2. Legal information and disclaimer	3
1.1.3. Safety issues	3
1.1.4. Electrostatic discharge awareness	3
1.1.5. Factory settings	3
1.2. About the application notes.....	4
1.2.1. General purpose	4
1.2.2. Intended users	4
1.2.3. Contents and overall structure	4
2. Single generator set	
2.1. System single-line diagram.....	5
2.2. AC connections.....	6
2.3. DC connections.....	7
2.3.1. Engine interface	7
3. Automatic Mains Failure	
3.1. System single-line diagram.....	8
3.2. AC connections.....	9
3.3. DC connections.....	10
3.3.1. Engine interface	10
4. Parellel with mains (grid)	
4.1. Applications.....	11
4.2. System single-line diagram.....	11
4.3. AC connections.....	12
4.4. DC connections.....	13
4.4.1. Engine interface.....	13
5. Load sharing	
5.1. System single-line diagram.....	14
5.2. AC connections.....	15
5.3. DC connections.....	16
5.3.1. Engine interface	16
6. Pt100 sensors	
6.1. Introduction.....	17
6.2. Connections.....	17
7. VDO sensors	
7.1. Introduction.....	18
7.2. Connections.....	18
8. 4-20 mA inputs	
8.1. Introduction.....	19
8.2. Connections.....	19
8.2.1. Multi-inputs	19
9. Digital inputs	
9.1. Introduction.....	20
9.2. Connection.....	20

1. General information

1.1 Warnings, legal information and safety

1.1.1 Warnings and notes

Throughout this document, a number of warnings and notes with helpful user information will be presented. To ensure that these are noticed, they will be highlighted as follows in order to separate them from the general text.

Warnings



Warnings indicate a potentially dangerous situation, which could result in death, personal injury or damaged equipment, if certain guidelines are not followed.

Notes



Notes provide general information, which will be helpful for the reader to bear in mind.

1.1.2 Legal information and disclaimer

DEIF takes no responsibility for installation or operation of the generator set. If there is any doubt about how to install or operate the engine/generator controlled by the Multi-line 2 unit, the company responsible for the installation or the operation of the set must be contacted.



The Multi-line 2 unit is not to be opened by unauthorised personnel. If opened anyway, the warranty will be lost.

Disclaimer

DEIF A/S reserves the right to change any of the contents of this document without prior notice.

1.1.3 Safety issues

Installing and operating the Multi-line 2 unit may imply work with dangerous currents and voltages. Therefore, the installation should only be carried out by authorised personnel who understand the risks involved in working with live electrical equipment.



Be aware of the hazardous live currents and voltages. Do not touch any AC measurement inputs as this could lead to injury or death.

1.1.4 Electrostatic discharge awareness

Sufficient care must be taken to protect the terminal against static discharges during the installation. Once the unit is installed and connected, these precautions are no longer necessary.

1.1.5 Factory settings

The Multi-line 2 unit is delivered from factory with certain factory settings. These are based on average values and are not necessarily the correct settings for matching the engine/generator set in question. Precautions must be taken to check the settings before running the engine/generator set.

1.2 About the application notes

1.2.1 General purpose

This document includes application notes for DEIF's Multi-line 2 unit. It mainly includes examples of different applications suitable for the unit.



For functional descriptions, the procedure for parameter setup, parameter lists etc., please see the Designer's Reference Handbook.

The general purpose of the application notes is to offer the designer information about suitable applications for the Multi-line 2 unit.



Please make sure to read this document before starting to work with the Multi-line 2 unit and the gen-set to be controlled. Failure to do this could result in human injury or damage to the equipment.

1.2.2 Intended users

The Application Notes are mainly intended for the person responsible for designing Multi-line 2 systems. In most cases, this would be a panel builder designer. Naturally, other users might also find useful information in this document.

1.2.3 Contents and overall structure

This document is divided into chapters, and in order to make the structure simple and easy to use, each chapter will begin from the top of a new page.

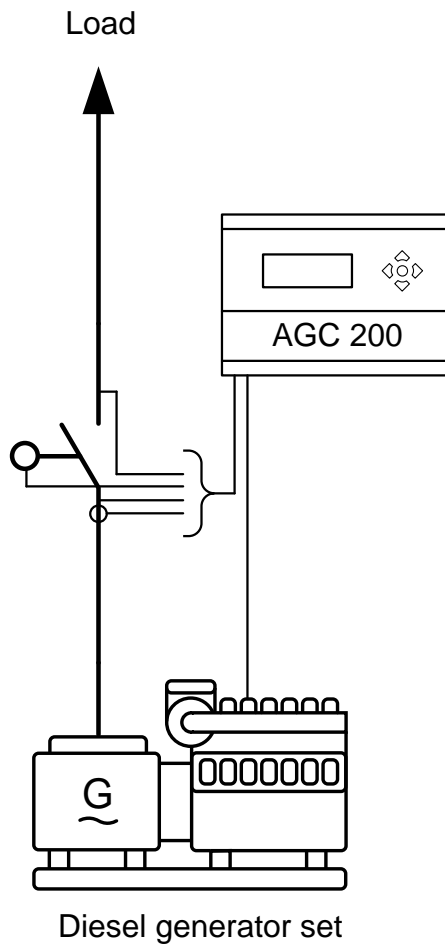

2. Single generator set

2.1 System single-line diagram

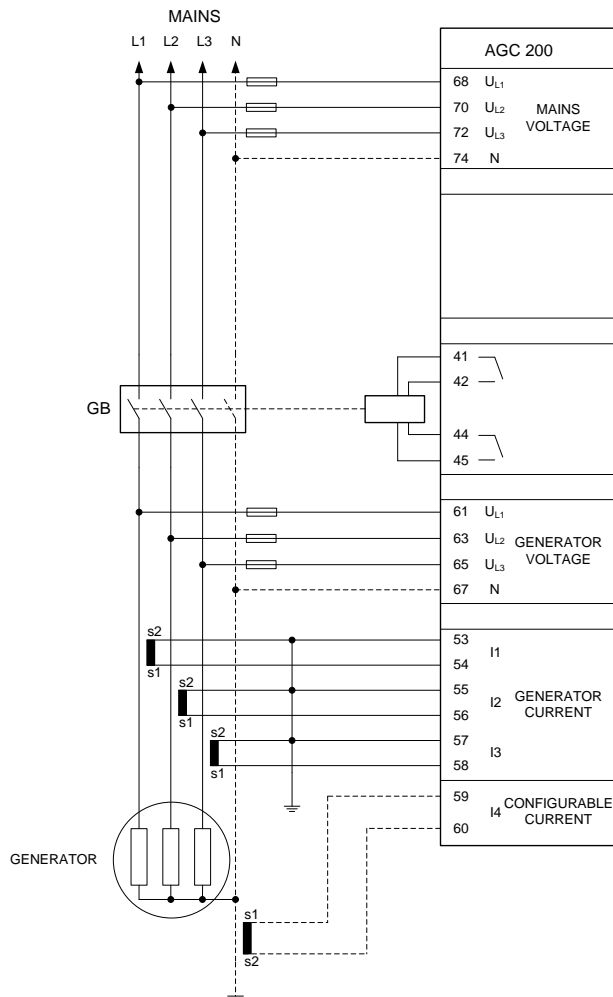

2.2 AC connections



-  A neutral connection is a possibility, not a necessity. AC voltages max. 690V AC phase-phase.
-  The configurable current input may or may not be used for ground current.
-  Regarding single phase and split phase (2-phase) systems, please refer to the Installation Instructions.

2.3 DC connections

2.3.1 Engine interface

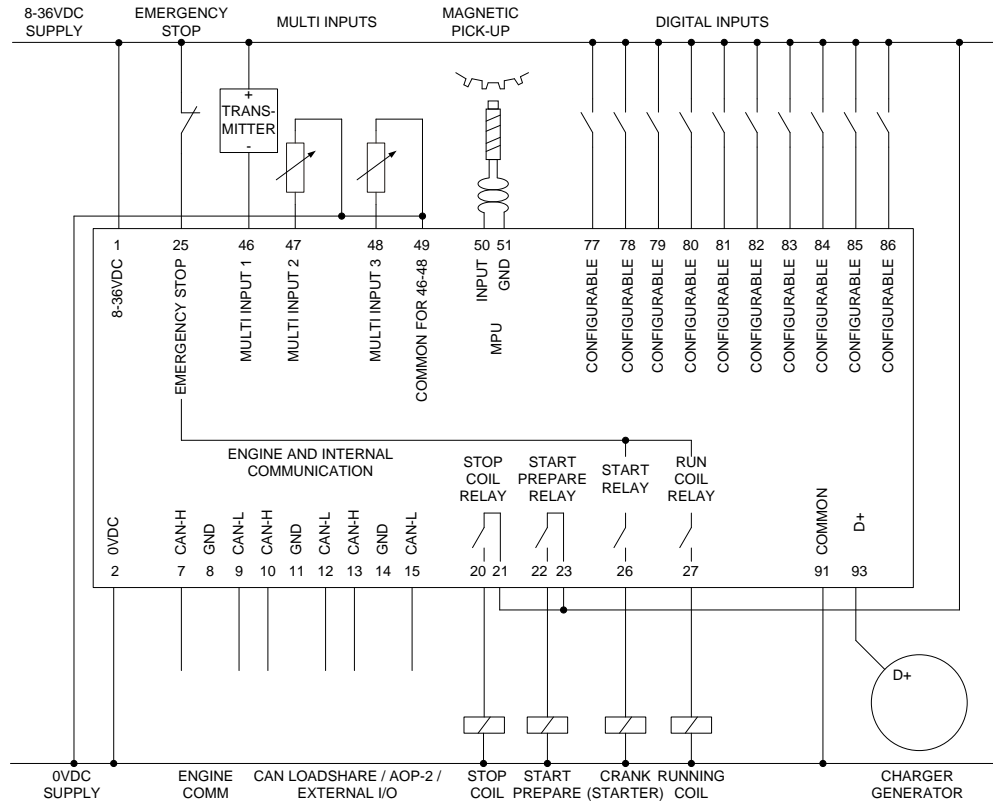

3. Automatic Mains Failure

3.1 System single-line diagram

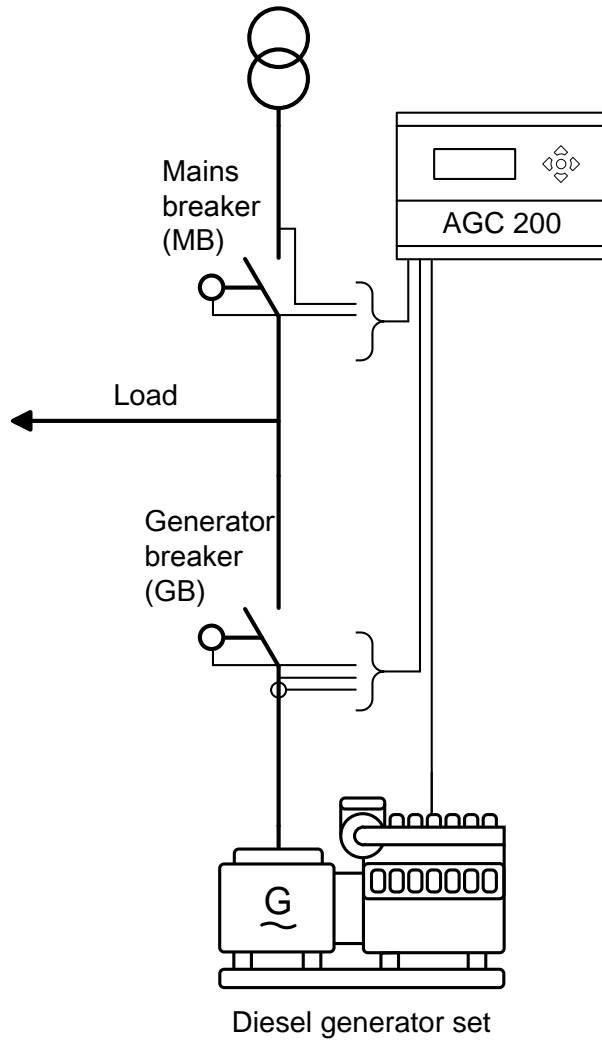

3.2 AC connections

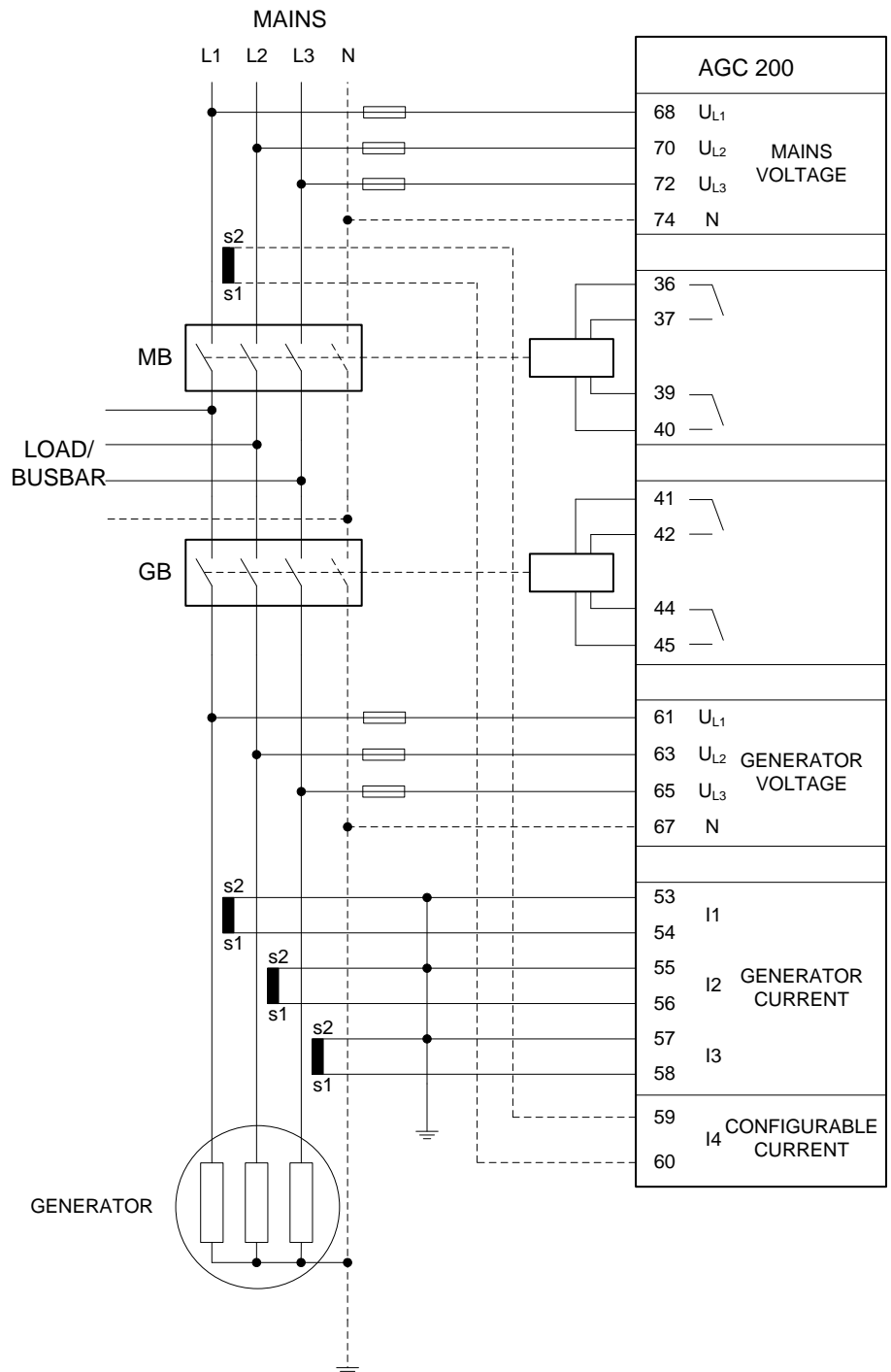

3.3 DC connections

3.3.1 Engine interface

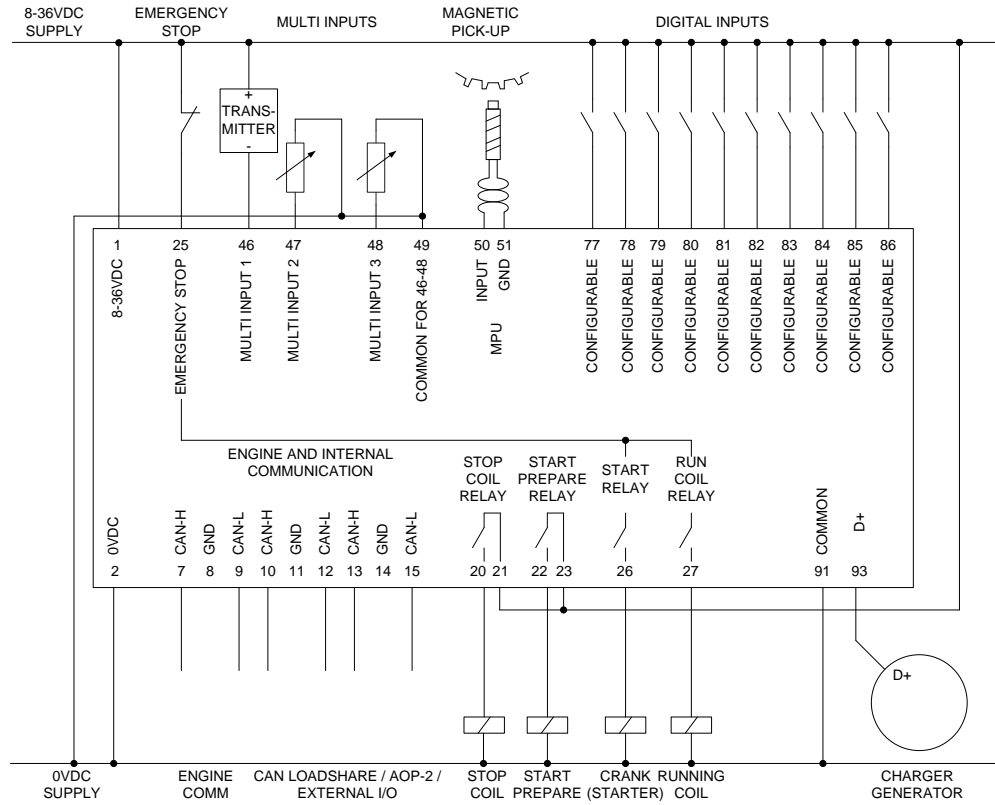

- i** A neutral connection is a possibility, not a necessity. AC voltages max. 690V AC phase-phase.
- i** The configurable current input may or may not be used for ground current.
- i** Regarding single phase and split phase (2-phase) systems, please refer to the Installation Instructions.

4. Parellel with mains (grid)

4.1 Applications

This application covers the genset modes peak shaving, fixed power, mains power export and load takeover.

The application can be combined with the stand-by AMF (Automatic Mains Failure) application by enabling the mode shift setting. In this case, the unit will automatically run the generator as a stand-by AMF generator in case of mains failure.

4.2 System single-line diagram

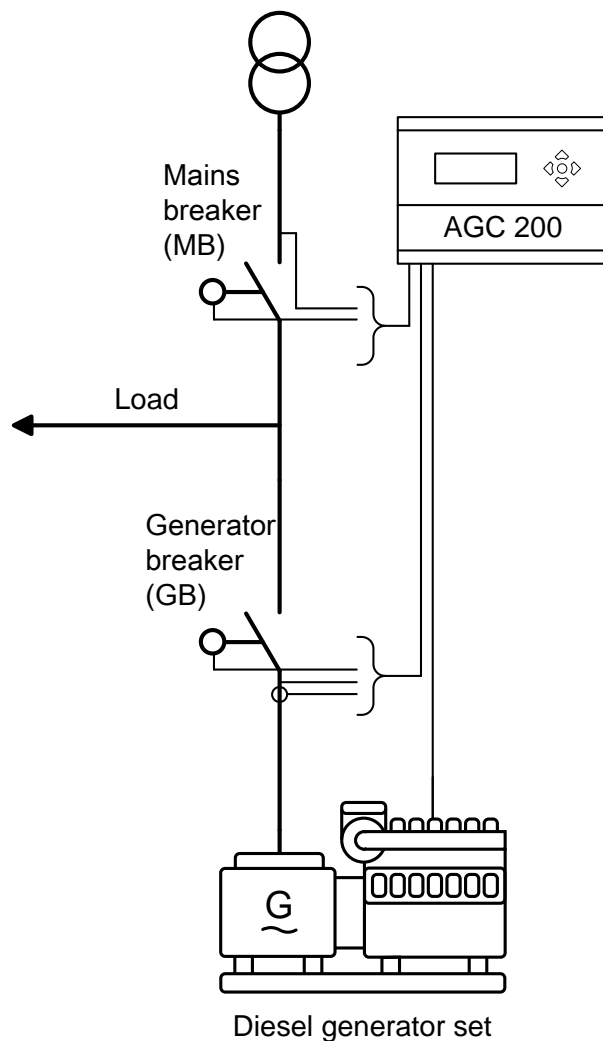

4.3 AC connections

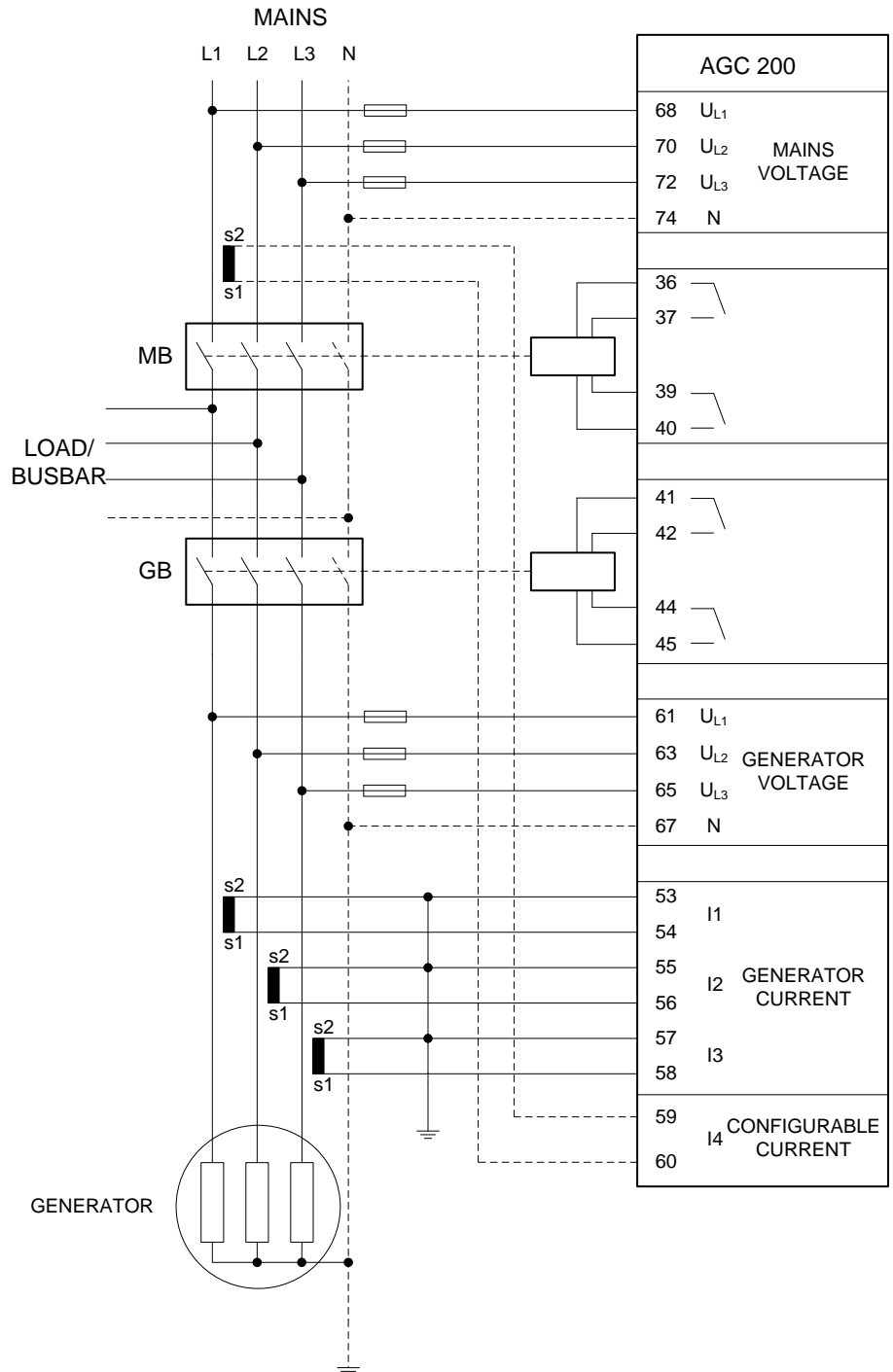

4.4 DC connections

4.4.1 Engine interface

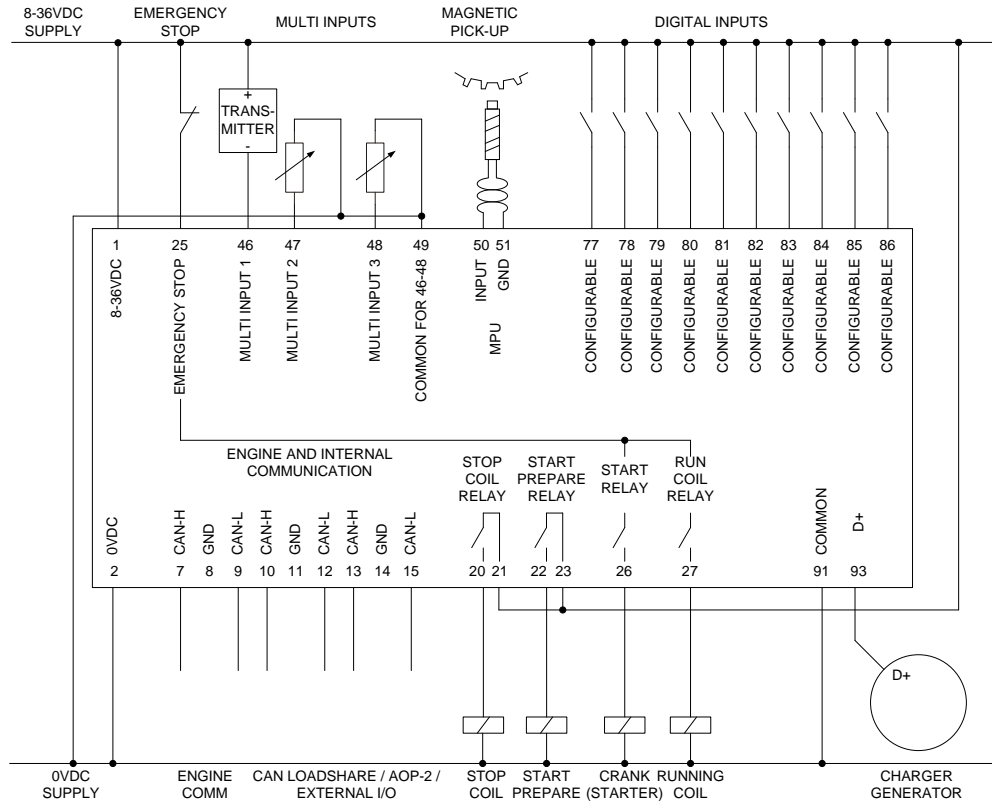

- i** The configurable current input may or may not be used. An AC power transducer can be used for mains power measurement instead. Mains power measurement is not necessary for fixed power applications.
- i** A neutral connection is a possibility, not a necessity. AC voltages max. 690V AC phase-phase.
- i** Regarding single phase and split phase (2-phase) systems, please refer to the Installation Instructions.

5. Load sharing

5.1 System single-line diagram

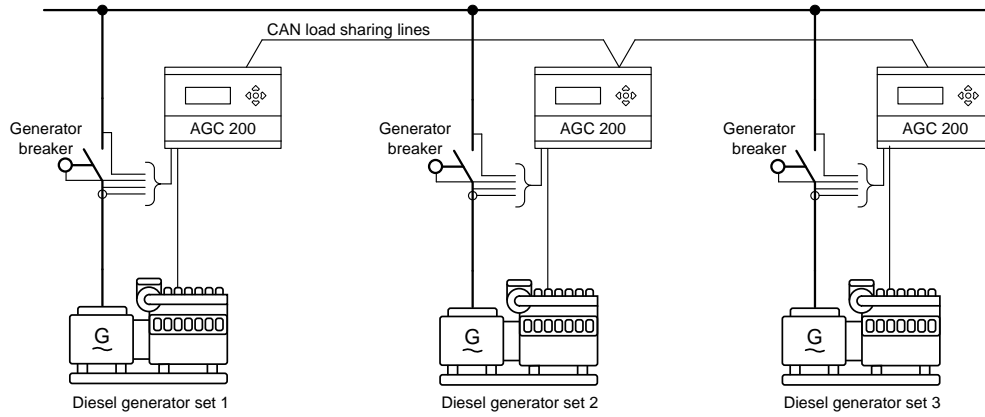

5.2 AC connections

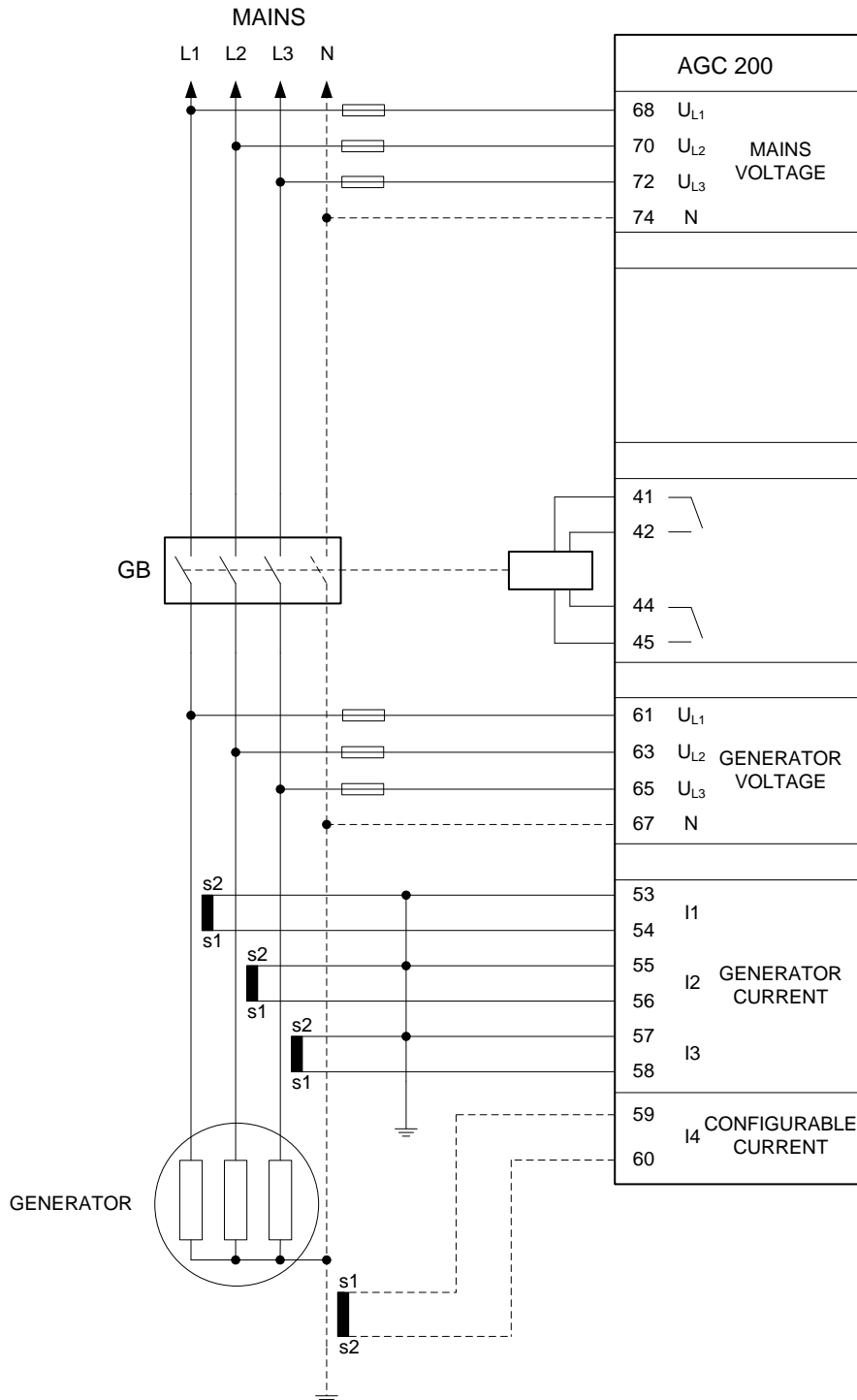

5.3 DC connections

5.3.1 Engine interface

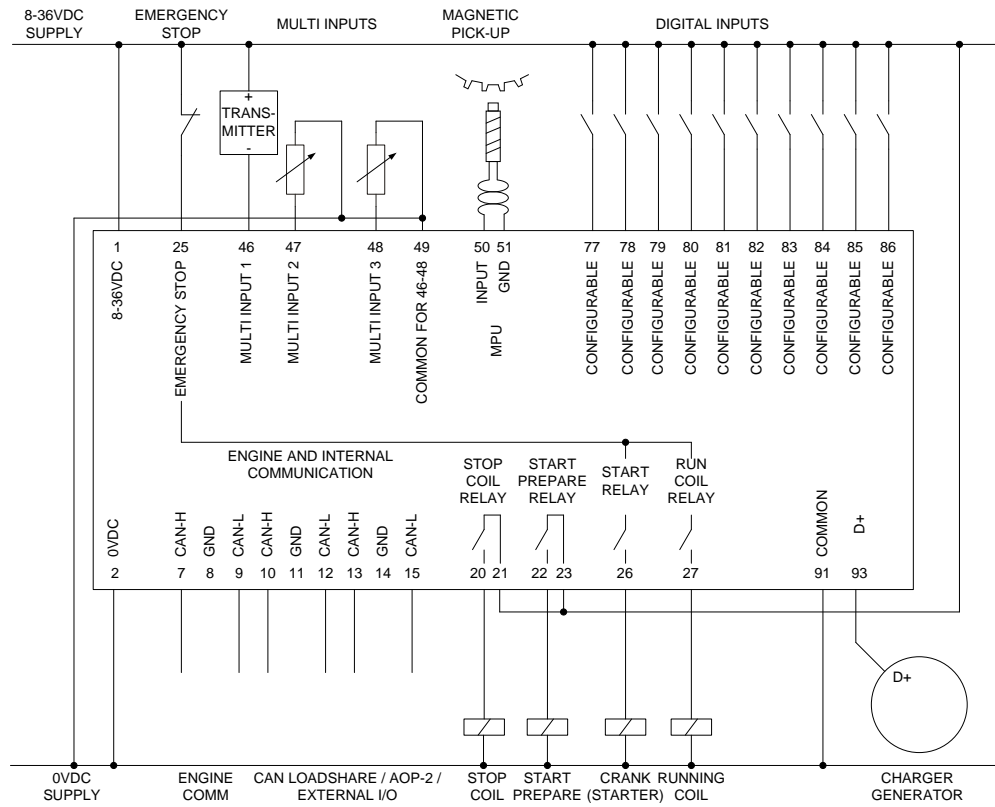

A neutral connection is a possibility, not a necessity. AC voltages max. 690V AC phase-phase.



The configurable current input may or may not be used for ground current.



Regarding single phase and split phase (2-phase) systems, please refer to the Installation Instructions.

6. Pt100 sensors

6.1 Introduction

The Pt100 inputs are available on the multi-inputs, terminals 46-48.



Pt100 sensors are also known as RTD sensors (**R**esistance **T**emperature **D**etector).

6.2 Connections

The input is designed for the 2-wire sensor, but the 3-wire sensor can also be used. The compensation is adjustable in the software.

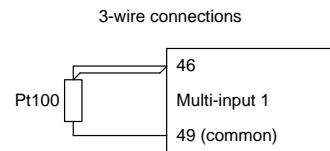
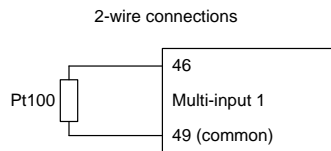

7. VDO sensors

7.1 Introduction

The VDO inputs are available on the multi-inputs, terminals 46-48.

7.2 Connections



The measurement is only a resistance measurement. It is not necessary to connect an auxiliary supply to the sender.

8. 4-20 mA inputs

8.1 Introduction

The 4-20 mA inputs are available on the multi-inputs, terminals 46-48.

8.2 Connections

8.2.1 Multi-inputs

Passive transducers

If the passive (2-wire) 4-20 mA transducers are used, the following connection must be used:

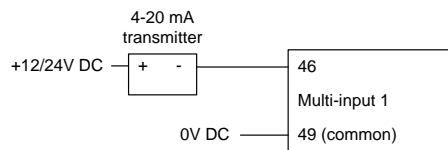

If the passive sensor has its own battery supply, the voltage must not exceed 30V DC.

Active transducers

Active transducers are connected like this:

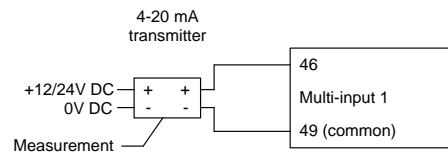

9. Digital inputs

9.1 Introduction

The digital inputs can be used as protection inputs or as function/control inputs. The protection inputs can be used as normally open or normally closed. When used as function/control inputs, they depend on the specific function and how the function is activated.



See a complete list of the digital inputs and input functions in the Designer's Reference Handbook.

9.2 Connection

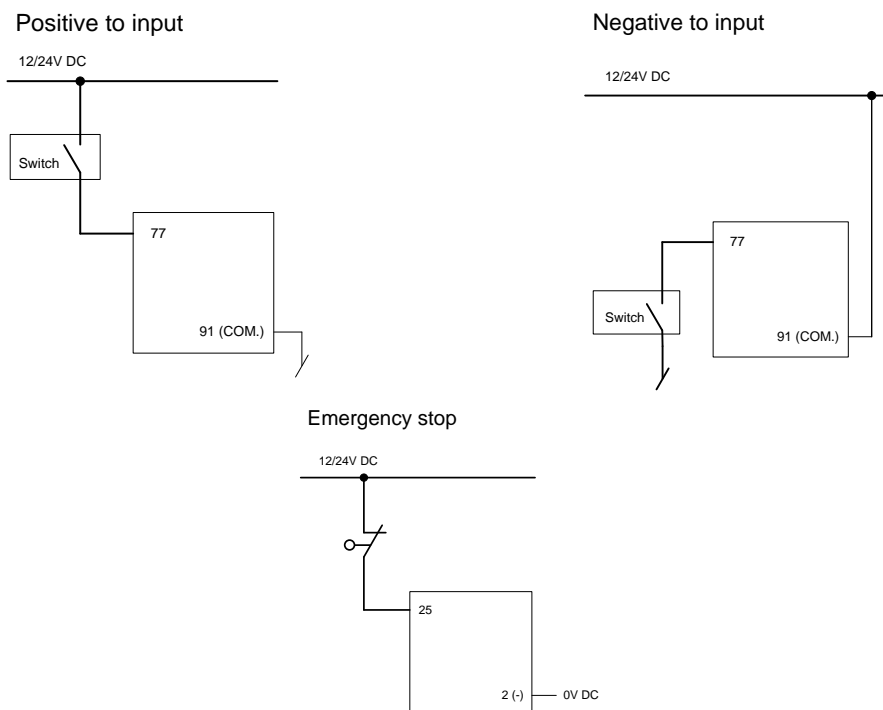

It is not possible to connect the emergency stop input to negative.