



**About AGC 150 ATS**

The AGC 150 Automatic Transfer Switch (ATS) controller can automatically transfer the power supply when it detects a failure.

The controller can handle all types of power sources and you can select how the controller should respond to a failure. The ATS can control up to three breakers, which means that you can use it in a wide range of emergency power solutions.

The values and alarms are shown on the LCD display screen, which is sunlight-readable. You can easily control the breakers from the display units. Alternatively, use the communication options to connect to an HMI/SCADA system.

**ATS features**

**Power sources**

The ATS can handle all types of power sources when in Source-Source mode. For example, two mains sources or a combination of a genset with battery energy storage system and a renewable power source. The controller can send a start and stop signal to both sources.

**Operating options**

The ATS uses Automatic Mains Failure (AMF) logic and user-defined control signals to control and monitor the application. The controller can monitor the primary power source for irregular voltages or frequencies, and switch to the secondary source if an irregularity is detected.

**Blackout prevention**

The ATS includes a closed transition function that prevents blackouts during source switching. The function keeps the breakers of both power sources closed for a user-defined period and enables short-time paralleling.

Functions	Stand-alone	Core
Open transition	●	●
Open delayed transition	●	●
Open in-phase transition		●
Closed transition		●
Closed transition with an adjustable overlap time		●
Priority of source: <ul style="list-style-type: none"> <li>• Prioritise S1</li> <li>• Prioritise S2</li> <li>• Shift priority at blackout</li> <li>• Prioritise both S1 and S2</li> <li>• Cyclic mode</li> </ul>	●	●
Power sources: <ul style="list-style-type: none"> <li>• Mains/mains</li> <li>• Genset/mains</li> <li>• Mains/genset</li> <li>• Genset/genset</li> </ul>	●	●
Elevator switch	●	●
External control of mains breaker	●	●
Protections	●	●

**Breaker control**

**1-breaker applications**

You can configure 1-breaker applications with 2 positions or 3 positions. There is no neutral in applications with 2 positions. In applications with 3 positions, there is a neutral position.

**2-breaker applications**

In a 2-breaker application, the controller automatically changes the supply if the primary supply fails.

**3-breaker applications**

The 3-breaker setup is for two sources and two load points. Use it in medium voltage ATS systems, such as in data centres. You can set source 1 or both sources as the primary source. A 3-breaker application allows you to open and close a bus tie breaker between the power sources.

The mimics on the display depend on the sources selected and the breaker configuration. For example, the display mimics for a mains/generator application are different from the generator/mains application.

1-breaker applications

One breaker and 2 positions

Generator-mains example

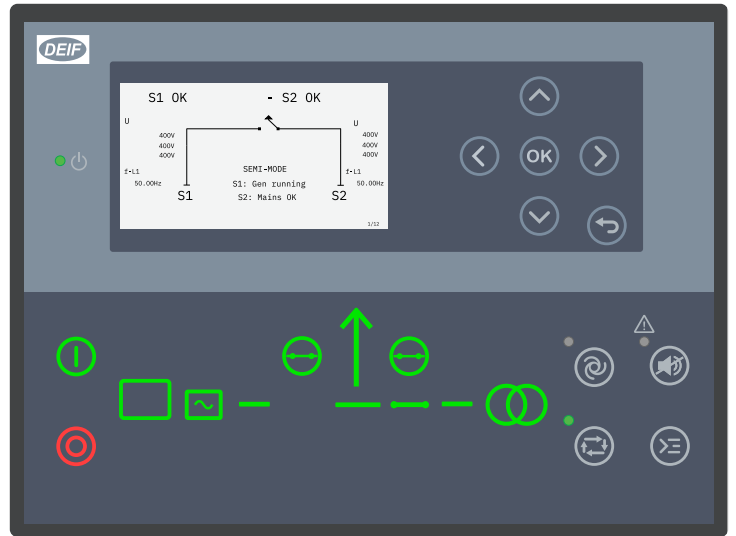
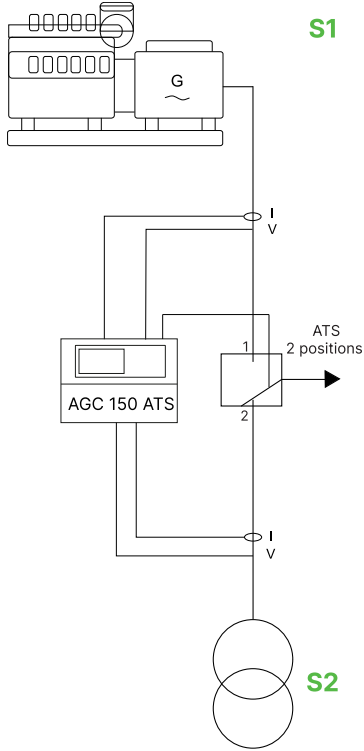

One breaker and 3 positions

Mains-generator example

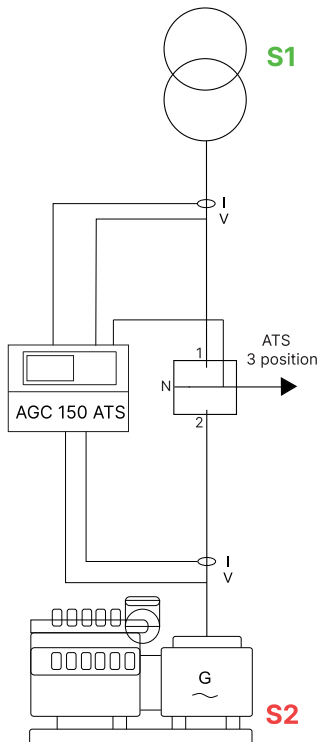

2- and 3-breaker applications

Two breakers

Mains-mains example

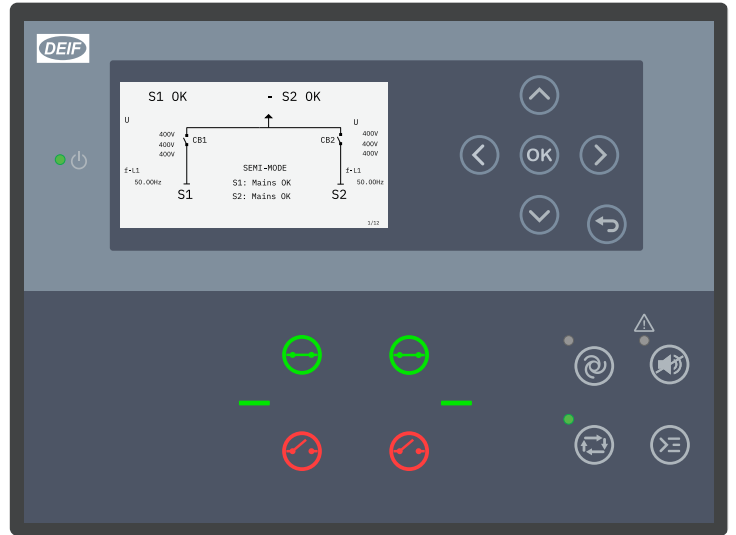
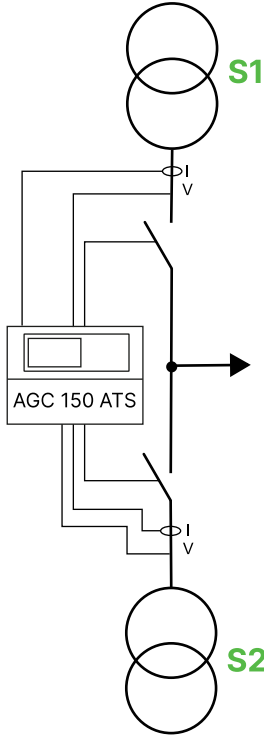

Three breakers

Mains-mains example

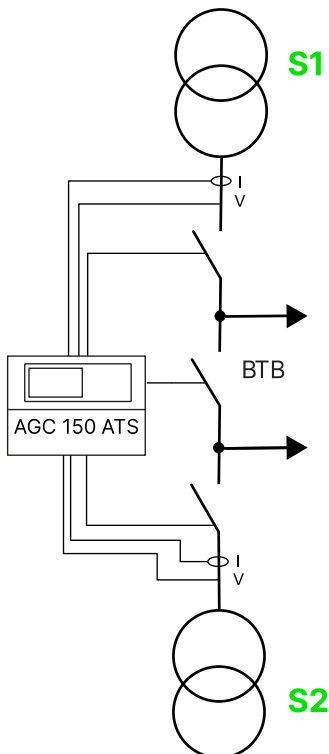

**AC measuring**

- Voltage: 100 to 690 V phase-to-phase (10 to 135 %), ±1 %
- Current: 1 A or 5 A (2 to 300 %), ±1 %
- Frequency: 3.5 to 75 Hz

**Power supply**

- Nominal voltage: 12/24 V DC
- Operating range: 6.5 to 36 V DC

**Inputs and outputs**

- Digital inputs: 12 x (max. +36 V, min. -24 V)
- Digital outputs:
  - 2 x (15 A inrush, 3 A continuously)
  - 10 x (2 A inrush, 0.5 A continuously)
  - Common: 12/24 V DC
- 4 x analogue inputs

**Environmental specifications**

**Operating temperature**

- -40 to +70 °C (-40 to +158 °F)

**Storage temperature**

- -40 to +85 °C (-40 to +185 °F)

**Communication**

- RS-485 Port 1
- RS-485 Port 2
- RJ45 Ethernet
- USB

**Approvals**

- CE
- UL/cUL Listed to - UL/ULC6200:2019 1.ed. Controllers for Use in Power Production

See [www.deif.com](http://www.deif.com) for the most recent approvals.

**Protections**

- 2 x Reverse power.....ANSI 32R
- 2 x Fast over-current.....ANSI 50P
- 4 x Over-current.....ANSI 50TD
- 2 x Over-voltage.....ANSI 59
- 3 x Under-voltage.....ANSI 27P
- 3 x Over-frequency.....ANSI 81O
- 3 x Under-frequency.....ANSI 81U
- 1 x Unbalanced voltage.....ANSI 47
- 1 x Unbalanced current.....ANSI 46
- 5 x Overload.....ANSI 32F
- Breaker open failure.....ANSI 52BF
- Breaker close failure.....ANSI 52BF
- Breaker position failure.....ANSI 52BF
- 1 x Phase sequence error.....ANSI 47
- Positive sequence (mains) voltage low.....ANSI 27
- Directional over-current.....ANSI 67
- Negative sequence voltage high.....ANSI 47
- Negative sequence current high.....ANSI 46I<sub>2</sub>
- Zero sequence voltage high.....ANSI 59U<sub>0</sub>
- Zero sequence current high.....ANSI 50I<sub>0</sub>
- Power-dependent reactive power.....ANSI 40
- IEC/IEEE inverse time over-current.....ANSI 51
- 1 x Emergency stop
- 1 x Breaker 1 (CB1) external trip
- 1 x Breaker 2 (CB2) external trip
- 1 x BTB external trip
- Synchronisation failure alarms
- 1 x Hz/V failure
- 1 x Not in Auto

**For more information:**

DEIF A/S  
 Frisenborgvej 33, 7800 Skive, Denmark  
 Tel.: +45 9614 9614, [info@deif.com](mailto:info@deif.com)  
[www.deif.com](http://www.deif.com)

